



Chilled ceiling guide, passive beams

Theory water cooling



Chilled ceiling guide, passive beams



Function

A chilled beam is a heat exchanger that transfers the heat in the room air to a cooling water circuit.

Heat transfer between the room air and a surface is achieved in two ways, in part, through heat radiation between the surface of the beam and the surrounding surfaces of the room and, in part, as convection between the air closest to the surface and the surface itself. These two heat transfer values are then added together to form the total heat transfer.

Chilled ceiling guide, passive beams

Natural convection technology

Heat transfer

A chilled beam is a heat exchanger which transfers the heat in the room air to a cooling water circuit. To avoid condensation, the temperature of the water supplied to the beam must not be too low (approx. +14°C). In the first stage, the heat in the room air is transferred to the surfaces of the chilled beam, and then it is conducted from the surfaces towards the pipe walls, where the next transfer, to the cooled water, takes place. Of the temperature difference between the temperature of the room air and the temperature of the cooling water circuit, 80 to 90% is between the air and the surface, and only 10 to 20% is between the pipe wall and the water. This applies, provided there is a turbulent flow in the water and arises because the heat transfer coefficient is many times higher in water than in air.

Heat transfer between the room air and a surface is achieved in two ways, in part, through heat radiation between the surface of the beam and the surrounding surfaces of the room and, in part, as convection between the air closest to the surface and the surface itself. These two heat transfer values are then added together to form the total heat transfer.

Heat transfer by radiation

It is important to know that heat transfer by radiation is only a transfer heat between the surfaces of the chilled beam and the surfaces of the room. This depends on the temperature difference between the surfaces and is independent of the temperature of the air.

It is relatively easy to calculate heat transfer by radiation by using the radiation equation:

$$P = A \times \varepsilon_t \times 5.67 \times \left(\left(\frac{T_{\text{chilled beam}}}{100} \right)^4 - \left(\frac{T_{\text{room}}}{100} \right)^4 \right)$$

P = effect (W)

A = area (m²)

ε_t = total emission coefficient

5.67 = Stefan-Boltzman's constant

T = temperature (K) (°C + 273)

ε is the ability of the material to absorb and emit heat. All normal materials in a room, apart from shiny metal, have an ε value of 0.88-0.97. Enamelled surfaces have an ε value of approx. 0.95, whereas glass, bricks and other materials have an ε value of approx. 0.9. For shiny metal, the ε value is approx. 0.1. This means that heat transfer through radiation cannot be utilised if the surfaces of the chilled beam or of the room are of shiny metal.

Assuming that the surfaces of the room completely surround the chilled beam, which is the most common situation, area A is counted as the surrounding area of the chilled beam. The surface of the chilled beam normally

has an ε value of 0.95. The total ε_t value is the value of the surface of the chilled beam multiplied by the ε value of the surfaces of the room. The ε value of the surfaces of the room can vary a bit, but as a rule, a ε value of 0.94 is selected for ordinary rooms.

The total ε_t value is therefore:

$$0.95 \times 0.94 \approx 0.9$$

An ε_t value of 0.9 is a good value to use for estimates.

Example

A 2 m strip beam (Capella Classic-53) has a surrounding heat transfer area of 2.6 m². This area has a temperature of + 16°C and the room surfaces a temperature of + 24°C. The value of the emission coefficient, ε_t , is assumed to be 0.9. What is the cooling effect provided by the chilled beam by radiation?

$$P = 2.6 \times 0.9 \times 5.67 \times \left(\left(\frac{289}{100} \right)^4 - \left(\frac{297}{100} \right)^4 \right)$$

$$P = 107 \text{ W}$$

Heat transfer by convection

Heat transfer by convection describes the process that occurs between the plate surface and the room air, which is very close to the plate surface. The heat transfer is calculated using the following equation:

$$P = \alpha \times A \times (T_{\text{chilled beam}} - T_{\text{room}})$$

P = effect (W)

α = heat transfer coefficient (W/m², °C)

A = area (m²)

T = temperature (K) (°C + 273)

Example

A 2 m strip beam (Capella Classic-53) has a surrounding heat transfer area of 2.6 m². This area has a mean temperature of + 16°C and the room's air a temperature of + 24°C. The mean value for all the heat transfer coefficient for all surfaces α , is assumed to be 10. What is the cooling effect provided by the chilled beam through convection?

$$P = 10 \times 2.6 \times (289 - 297)$$

$$P = 208 \text{ W}$$

Conclusion

According to the calculation example above, the cooling effect provided by radiation is approx. 107 W and by convection approx. 208 W. This gives a radiation percentage of approx. 34% and a convection percentage of approx. 66%.

One problem with calculating heat transfer by natural convection is to find the correct heat transfer coefficient α value. The heat transfer coefficient between the air and the surface varies, partly depending on the temperature difference and, in part, on the size and inclination of the surface. A higher temperature difference results in a greater heat transfer coefficient. Horizontal surfaces provide a higher heat transfer coefficient for small surfaces (less than 1 m wide).

Chilled ceiling guide, passive beams

While a flat vertical surface, which is approx. 1 m wide, has a heat transfer coefficient of only 3 W/m² °C, a 5 cm wide surface has a heat transfer coefficient of 5 W/m² °C, and 1 cm wide surface has a heat transfer coefficient of 10 W/m² °C (a temperature difference of 10°C).

To increase the effect of a natural convection beam, the cooled air, which is somewhat heavier, can be utilised. This can be done by manufacturing a chilled beam with higher sides, where a cold heavy volume of air develops beneath the beam, and it increases the air velocity past the surfaces of the chilled beam, thereby increasing the heat transfer coefficient.

Why is it important to calculate radiation and convection?

Since radiation concerns heat transfer between surfaces, it does not affect the air velocities in the room. On the other hand, heat transfer by convection creates air movement since for it to take place, air must pass through the heat-transfer surfaces.

When making calculations for natural convection beams and resulting air velocities, only the convective transfer can be taken into account when it comes to the creation of air movements.



Picture 1. The strip product Capella can be installed suspended and in a suspended ceiling.

Static and dynamic pressure and their effect on air movements in a room.

When the air in a room reaches a certain velocity, it tends to drag the adjacent air along, which, in turn, affects the resulting air velocity in the room. What happens to the air movement in a room can be explained theoretically with a simple equation:

$$P_{\text{total}} = P_{\text{static}} + P_{\text{dynamic}}$$

$$P_{\text{dynamic}} = \frac{\delta \times v^2}{2}$$

P_{total}	= total pressure (Pa)
P_{static}	= static pressure (Pa)
P_{dynamic}	= dynamic pressure (Pa)
δ	= density (kg/m ³)
v	= velocity (m/s)

This equation explains the phenomena that occur in a room and it also explains why an airplane can fly, a sailboat can go against the wind, and an induction beam can work, and it also explains many air velocity phenomena that occur under natural convection beams.

The dynamic pressure is the same as the velocity pressure, i.e. the pressure that is formed as a result of the air velocity. In a room, the total pressure is always the same, unless there is a pressure drop. This means that if an air velocity is created, there is dynamic pressure, which automatically creates lower static pressure in the room. A volume unit in an air jet, which has a velocity, has lower static pressure than the surrounding air, and as a result, the surrounding air will accelerate towards the air jet and in doing so, will compress it and make the air jet narrower.

When the heavier, colder air leaves the natural convection beam with a certain velocity, the room air from the sides will move towards the air jet and compress it. This means that the air velocity underneath a natural convection beam is higher when it is below the beam than when it leaves the outlet of the beam. As a result, air velocities are also relatively similar under all natural convection beams, irrespective of the width of the respective beam. A wide beam creates a narrower column of air a few decimetres below the beam, with a similar column shape, is created by a narrower beam.

Chilled ceiling guide, passive beams

If natural convection beams are placed close to each other, with only a small separation between them, there will not be enough room air between the air streams, and the low static pressure in the air streams will cause the room air to compress these into a single air stream with a higher air velocity.

The same phenomenon occurs if a natural convection beam is placed close to a wall. The room air cannot pass between the air stream and the wall but instead presses the air stream from the beam towards the wall. This phenomenon is called the Coanda effect when it occurs near the ceiling. However, it also occurs when a natural convection beam is placed close to a wall.

The compression of the air jet that occurs below the beam, as a result of the pressure exercised by the room air, decreases lower down when the room air mixes with the cooled air. The air becomes lighter and expands. Where this occurs, depends to a certain extent on the height of the room. In a high room, the air falls further below the natural convection beam before it expands. In a lower room, the air has a shorter distance to go since the floor completely stops the air stream. The air velocity is relatively independent of the ceiling height in normal rooms with a ceiling height of 2.5 to 3.0 m.

Draughts are more than air velocity

A Draught is normally defined as undesired local cooling of part of the body and is caused by air movements. The experience of draughts is affected by the air velocity, the air temperature and the turbulence intensity.

As mentioned before, turbulence in the air stream also has a significant influence on the risk of draughts. A measure of turbulence is the turbulence intensity. Turbulence intensity is an expression of how much the air velocity in an air stream varies in relation to the mean velocity of the air stream; i.e. it is the combination of air velocity, air temperature and turbulence intensity that determines the risk of experiencing a draught. Different relations between air velocity, air temperature and turbulence intensity can generate the same level of draught risk.

The formula for turbulence intensity is, as follows:

$$T_u = \frac{SD_v}{\bar{v}} \times 100$$

T_u = turbulence intensity
 SD_v = standard deviation
 \bar{v} = mean velocity

Example

What is the turbulence intensity when the standard deviation is $SD_v = 0.05$ m/s and the mean velocity is $\bar{v} = 0.16$ m/s?

$$T_u = \frac{0.05}{0.16} \times 100$$

$T = 31\%$

Comparison between battery and strip products

Depending on how the natural convection products are manufactured, they can be divided into two groups, battery and strip products. Battery products utilise convection, whereas strip products utilise convection and radiation for their heat transfer.

The battery products (see picture 1) include a cooling battery, which consists of copper pipes with transversely positioned aluminium fins, 5 mm apart from each other. This battery is designed to transfer heat through convection. The design allows the creation of a very large heat transfer surface in a small volume. Thus, the products can be made relatively small and still be highly efficient. Moreover, the battery can be built in so that only the supply and return are visible. As a result, the products are flexible, from the point of view of design. Since the battery is located inside the product, very little of the cold is conducted out to the product casing, which means that the cooling effect is achieved solely through convection.

The strip products (see picture 2) are built up in a way completely different from the battery products. Here the energy is transferred completely to the outer surfaces of the product.

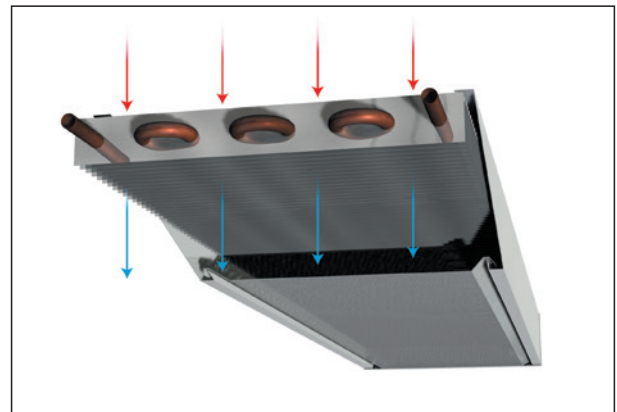

Picture 2. In a battery beam, heat transfer is achieved via convection.

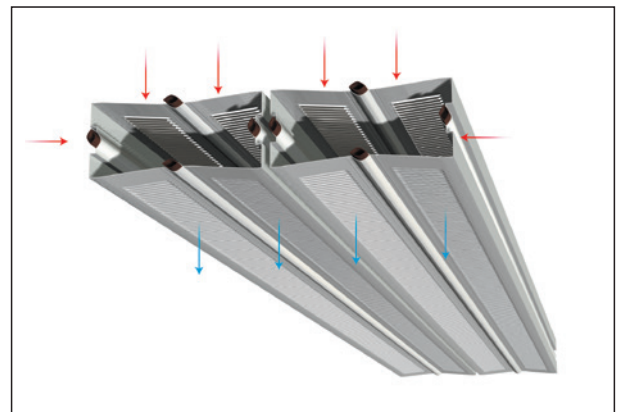

Picture 3. In a battery beam, heat transfer is achieved through both convection and radiation.

Chilled ceiling guide, passive beams

The surfaces, however, can be opened by way slots or perforations to allow an air stream to pass through, thereby increasing the effect per material/surface unit. These openings are usually shaped like narrow fins so as to achieve high heat transfer coefficients. In this way, we can get a product that transfers heat or cold with relatively small surfaces. As the surfaces are located entirely inside the casing – so as to allow radiation exchange between the casing and the room surfaces, the surrounding area of the product becomes somewhat larger than that of a corresponding battery product. The technology also has certain aesthetic limitations, if its operation is to be adequate. A strip product can naturally be placed above a perforated suspended ceiling; however, the radiation quotient will be lower than with suspended installation.

The advantage of strip products compared to battery beams is that they can provide approx. 50% higher effect with the same air velocity, due totally to the radiation quotient. A smaller total surface also results in a light product, which is easier to clean. The strip beams transfer their energy by means of natural convection in the thin slots and by radiation. This means that unlike a battery beam, the effect curve is almost linear in relation to the temperature increase. If the temperature difference between the mean water temperature and the room temperature is 4°C, the effect yield is approx. half of the yield provided with a temperature difference of 8°C. This means that in a dynamic temperature process, where the room temperature varies during the day, the accumulation of cooling in the building structure can be utilised more efficiently.

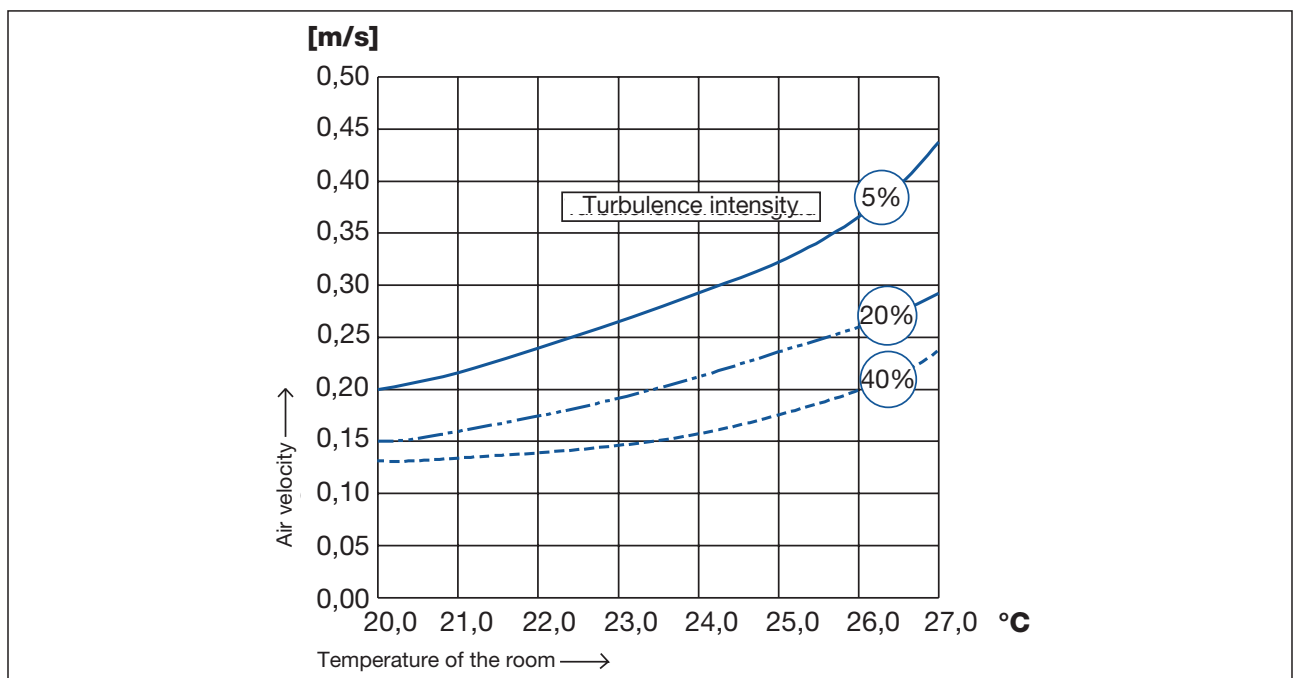

Diagram 1. Based on the calculated turbulence intensity and the temperature of the room air, the maximum air velocity that does not create draughts can be read off from the diagram DIN 1946.

Chilled ceiling guide, passive beams

The result is a lower room air temperature at the same installed effect. This also means that strip beams are relatively independent with regard to placement, unlike battery beams that require a certain velocity through the fins to work and are more sensitive to misplacement and obstacles in the air stream.

The radiation emitted by the strip products also means that the experience of the climate is better at the same room temperature. Since approx. 30 to 35% of the cooling effect is transferred by radiation, there is a direct heat exchange between an individual and the chilled beam, which means that it feels somewhat cooler with the same ambient air temperature.

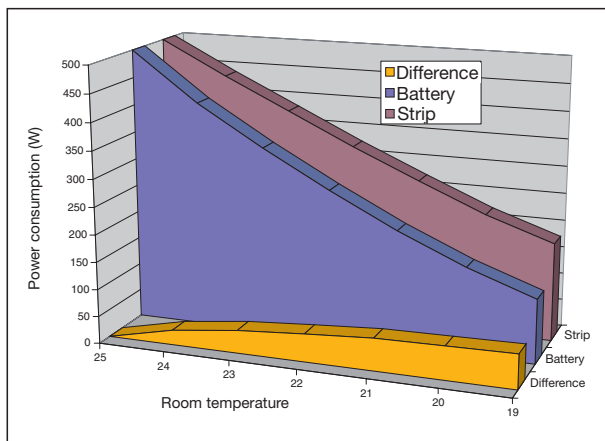

Diagram 2. This diagram illustrates the battery and strip products in a dynamic process. It shows that strip products have higher power consumption than the battery products, up to the room's maximum temperature of 25°C.

Chilled ceiling guide, passive beams

Measurements & calculations

Presentation of measurements and calculations of air velocities

All measurements and tests presented in this Guide were conducted in Lindab Indoor Climate Solutions climate laboratory, a modern equipped laboratory, with high flexibility for different types of measurements.

The measurements were conducted in accordance with the Guidelines for the Measurement of Air Velocities of the Swedish Association of Heating and Ventilation Engineers. The measured values are presented as the mean values of a measurement series at certain selected measuring points during a period of 3 minutes. The heating was supplied to the measurement room through the walls and floor in order to minimise its effect on air velocities. Air velocities in the occupied zone were calculated as the mean value between 1200 and 1800 mm above the floor, with the bottom side of the beam at 2600 mm above floor level.

The measuring instruments used were of the type ALNOR, model AVT-75. The measuring points were placed with c-c 100 mm at heights of 100, 1200 and 1800 mm above floor level.

Battery beam refers to a chilled beam that consists of a finned battery with transversely positioned fins attached to a copper pipe. An ordinary battery beam conducts approx. 95% of the heat transfer via convection and approx. 5% via radiation.

Strip beam refers to a chilled beam that consists of pipes with fins forming the surfaces of the beam. The top and bottom sides are slotted to allow air to pass through. An ordinary strip beam conducts approx. 65% of the heat transfer via convection and approx. 35% via radiation.

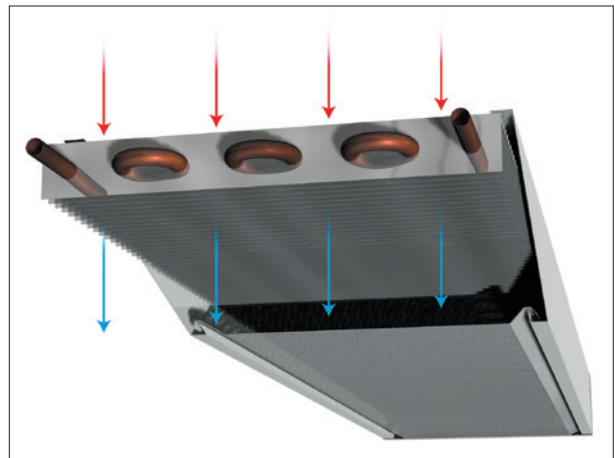

Picture 4. Operation, battery beam.

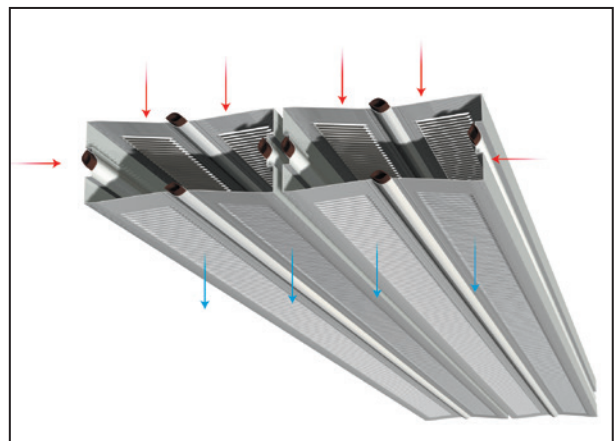

Picture 5. Operation, strip beam.

Chilled ceiling guide, passive beams

Performance and characteristics

A summary of the characteristics of passive and active chilled beam systems can be found in the table below:

Characteristic		Passive 95% convection (Section 3.5)	Passive 65% convection 35% Radiant Absorption (Section 3.6)
Potential cooling capacity*	W/m Cooling	≤ 225 W/m	≤ 300 W/m
	W/m ² Cooling	≤ 75 W/m ²	≤ 100 W/m ²
Potential heating capacity (both air and waterside heating)	W/m Heating	N/A	N/A
	W/m ² Heating	N/A	N/A
Installation location	Above ceiling	Yes	Yes
	In ceiling	Yes	Yes
	Below slab free hanging	Yes	Yes
Air circulation	Air entry	Grille / opening	Perforated tile
	Air discharge	Vertical	Vertical
Functions	Cooling	Yes	Yes
	Heating	No	No
	Ventilation	No	No
Noise	Air flow	Very low	Very low
Important considerations	Entry area for induced air	Unit top surface area	Unit top surface area

* Based on:

A) EN14518 Passive beams

B) Temperature difference room to mean water temperature = 8°K

C) Water flow return temperature difference = 2°K

D) Room temperature 24°C

E) Water mean temperature 16°C

F) Chilled beam pitch 3m

Notes

1. Passiv chilled beam performance – The maximum cooling effect of up to 225 W/m applies to passive beams (circa 95 per cent convective elements) and is based upon comfort criteria as recommended within EN ISO 7730 (PPD < 15 per cent).
2. Convection only passive chilled beam designs are capable of higher levels of cooling (greater than 225 W/m), however, careful consideration should be given at design stage to ways to limit draught and guarantee occupant comfort; the chilled beam conditioned air discharge, when in excess of 225 W/m, should be introduced in areas deemed outside that of the normal occupied zone (such as within 0.6 m of the façade as referenced in ASHRAE 55 and PD CR 1752:1999).
3. When passive chilled beams with a higher percentage of radiant absorption are providing above 300 W/m cooling, care should be taken to ensure that comfort criteria is within that shown in BS EN ISO 7730 (PPD < 15%).

CBCA – An introduction to Chilled Beams and Ceilings, July 2012 version 1.

Chilled ceiling guide, passive beams

Measurements & calculations

Effect per active metre at different air velocities for strip and battery beams

Diagram 3 shows air velocity in the occupied zone under a battery or strip beam in a room with a ceiling height of 2.6 m. The diagram illustrates, for example, that with a maximum air velocity of 0.25 m/s, the value of 110 W/m and 175 W/m per beam should not be exceeded for a battery beam and a strip beam, respectively.

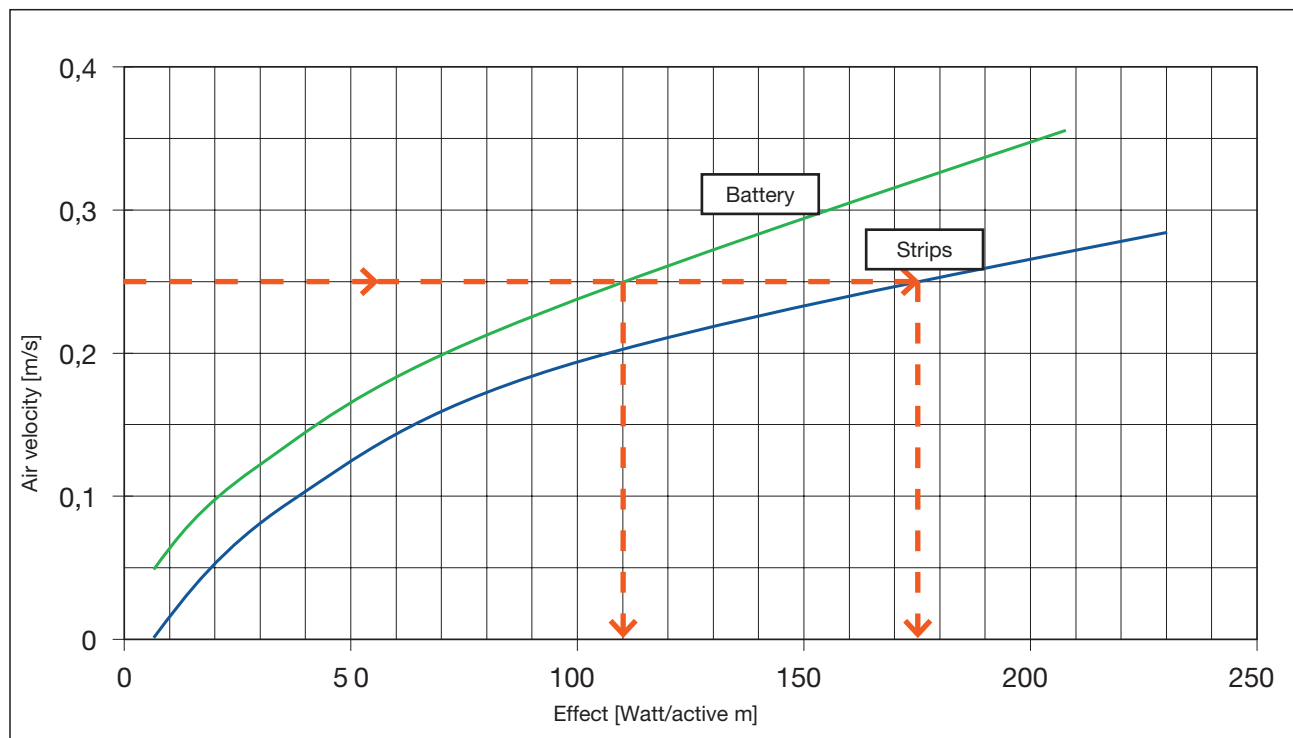

Diagram 3. Air velocity / Watt per active metre.

Chilled ceiling guide, passive beams

Measurements & calculations

Effect per active metre at different air velocities for strip and battery beam

A large number of measurements were conducted to create diagram 3. Figure 1 shows two examples from this measurement series, with an effect of 150 W/m, where it is apparent that the air velocities are acceptable for a strip beam but are too high for a battery beam. The examples show how the low static pressure of the air jet causes the air jet underneath the beam to compress to a narrower shape.

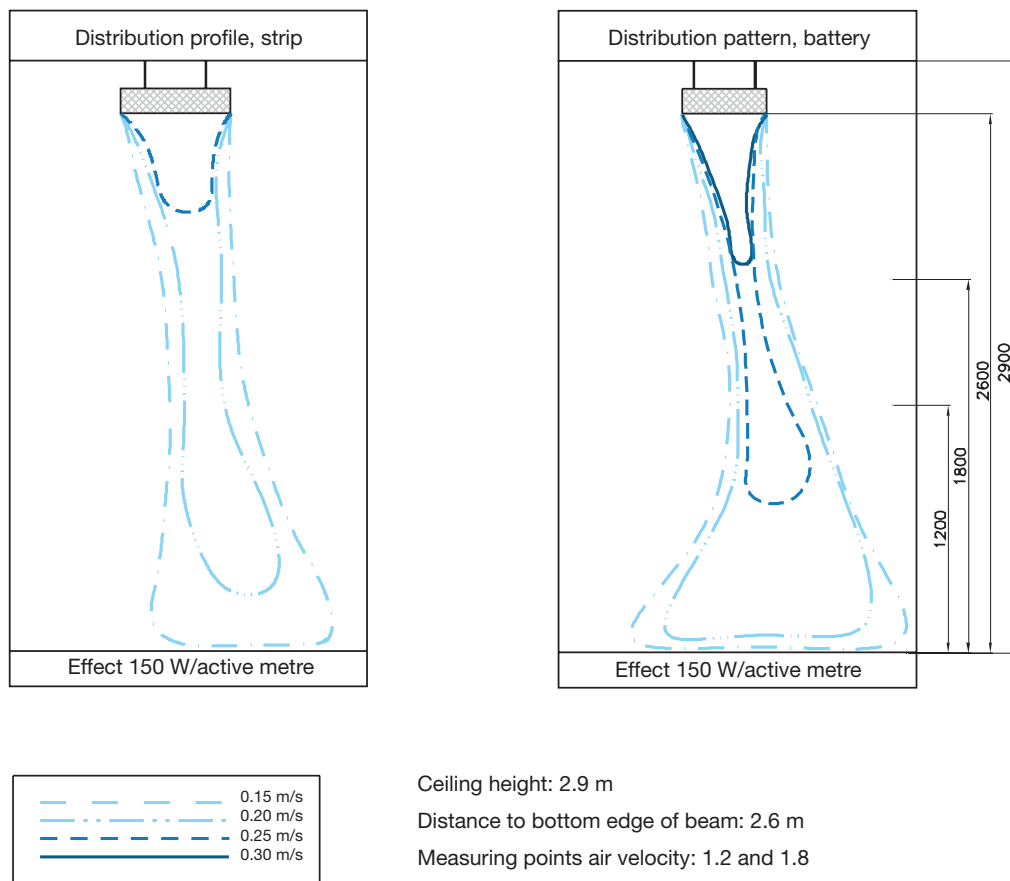

Figure 1. Air velocity for strip and battery beams.

Chilled ceiling guide, passive beams

Measurements & calculations

Effect per active metre at different air velocities for strip and battery beams.

Figure 2 shows air velocities with an effect of 110 W/m in a battery beam, in part, across the beam and, in part, alongside the beam. The corresponding effect for a strip beam is 175 W/m with the same air velocity profile.

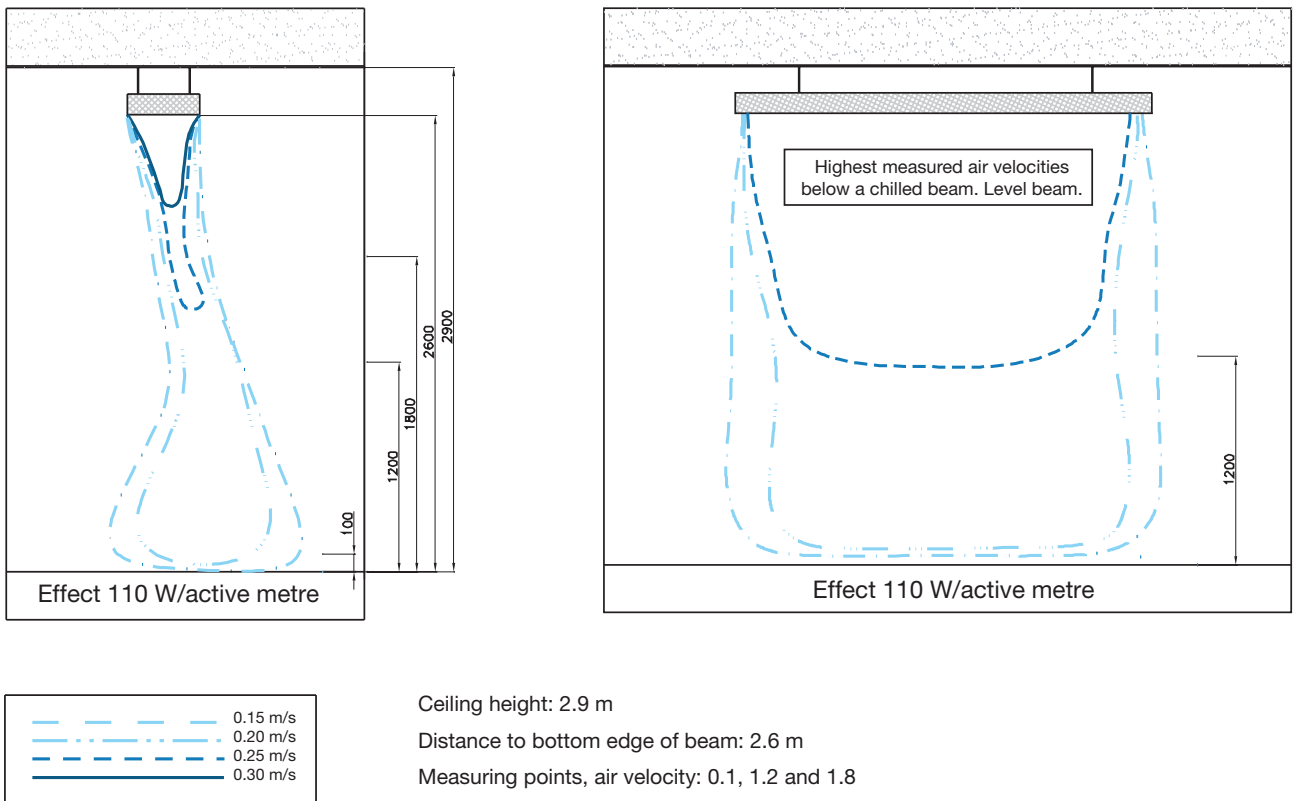

Figure 2. Air velocity for battery beams.

Chilled ceiling guide, passive beams

Influence of beam width on air velocity

To assess if a wide beam generates lower air velocities than a narrower one, measurements were taken for beams with different widths. Diagram 4 shows that the width is only of marginal importance for the air velocities. If the width of a battery beam is doubled from 42 cm to 84 cm, the air velocity is reduced by only 10%. The reason for this is that the air jet is compressed below the beam and is given a similar shape and velocity, regardless of whether the beam is wide or narrow. The same applies to strip beams.

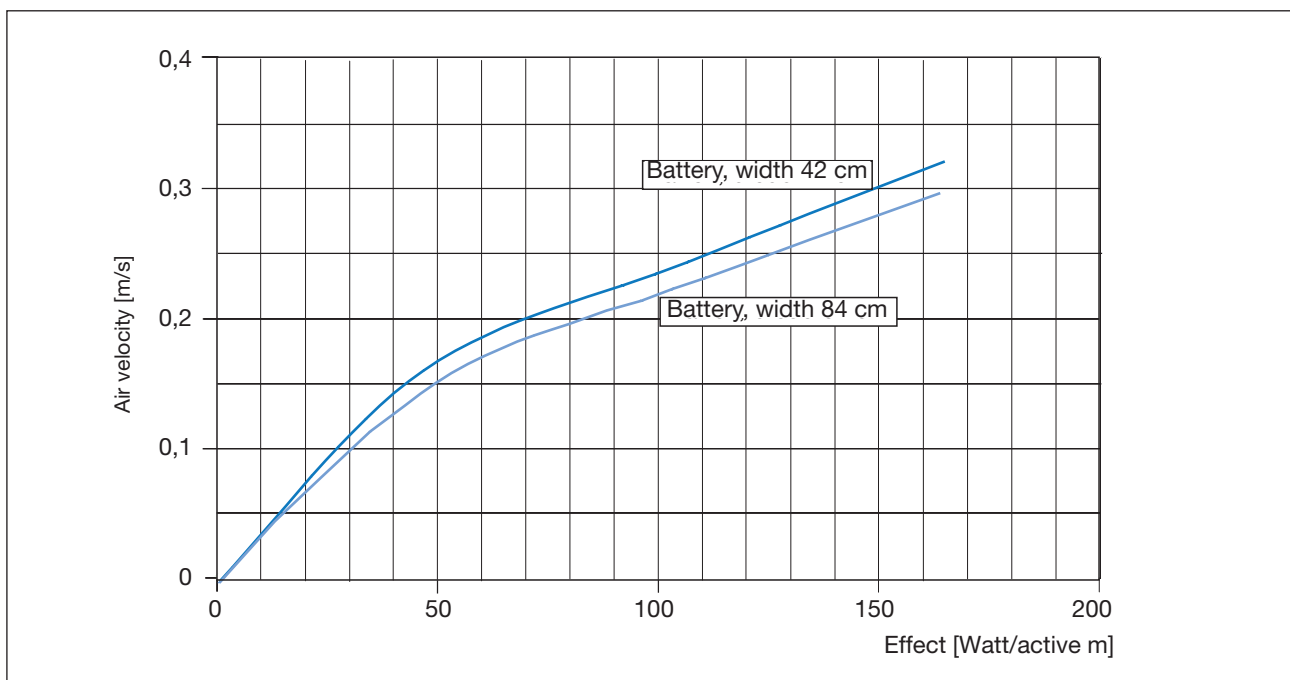

Diagram 4. Air velocity with different beam widths.

Chilled ceiling guide, passive beams

Measurements & calculations

Air velocity in the occupied zone depending on ceiling height

Figure 3 shows the air velocity in a room with a battery beam placed at different heights. The figures show clearly that air velocities are not affected appreciably, whether the room is high or low, at least within the range of 2.6 to 3.0 m above floor level. A marginal reduction in air velocity can be observed if the ceiling becomes higher. Lower velocities can be assumed in the occupied zone first when the ceiling height is well over 3.0 m.

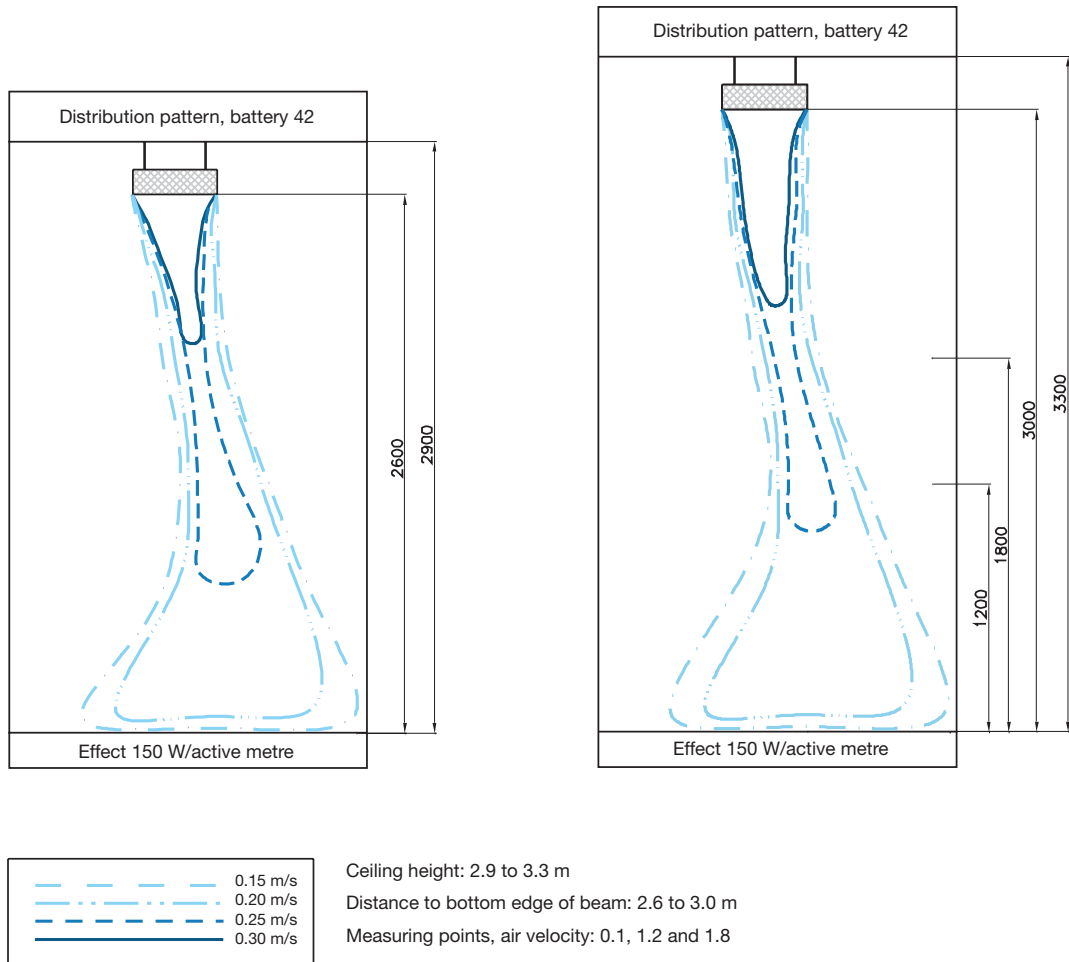

Figure 3. Air velocity at different ceiling heights.

Chilled ceiling guide, passive beams

Measurements & calculations

Air velocity when beams are installed next to one another

Figure 4 shows what happens when chilled beams are installed next to one another. The selected effect was 110 W/m per metre of battery beam, i.e. the power considered to be the maximum acceptable for a single battery beam. If a strip beam is used instead, the corresponding power can be set to 175 W/active metre. The beam in the examples is 42 cm wide. With two beams next to each other, 800 mm centre to centre, an air velocity in the room equal to a single beam is achieved. However, the air streams underneath the beams are still affected by each other. The figures show how the air streams are drawn towards each other due to the low static pressure in the air column, which tends to draw the room air towards itself. As air cannot rise between the beams in sufficient volumes, the air streams underneath the beams are drawn together. It is first, at a distance of 1.2 m between the centres of the beams, they function properly as two separate beams from the point of view of the aerodynamics.

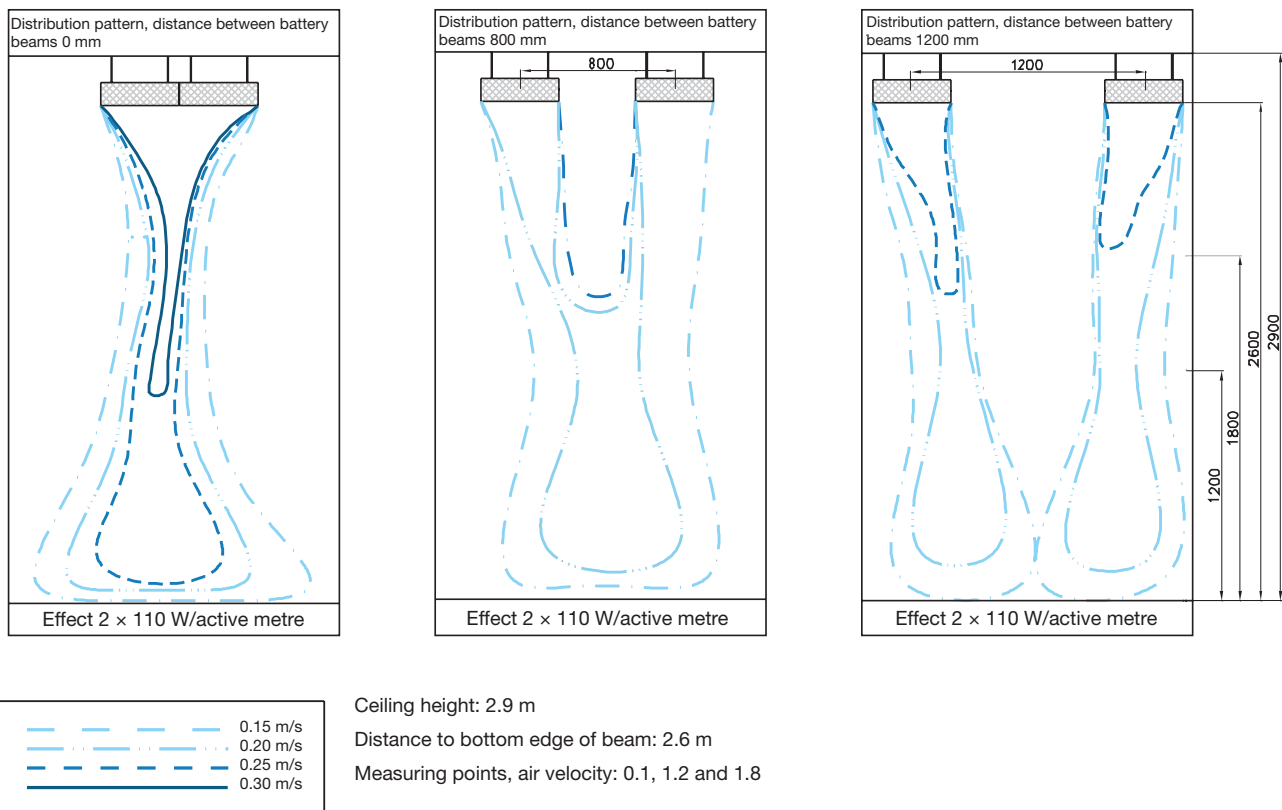

Figure 4. Air velocity with different distances between two beams

Chilled ceiling guide, passive beams

Measurements & calculations

Air velocity when beams are installed next to one another

Diagram 5 shows the mean air velocity of 1.6 m above floor level as a function of different c-c (centre to centre) beam dimensions. It shows that a c-c distance of 800 mm, and greater, generates more or less the same air velocity as with a single beam. There is a certain minimum level at a c-c distance of 800 mm, since at this distance, the lateral movement of air is at its maximum, and it decreases somewhat the air velocity.

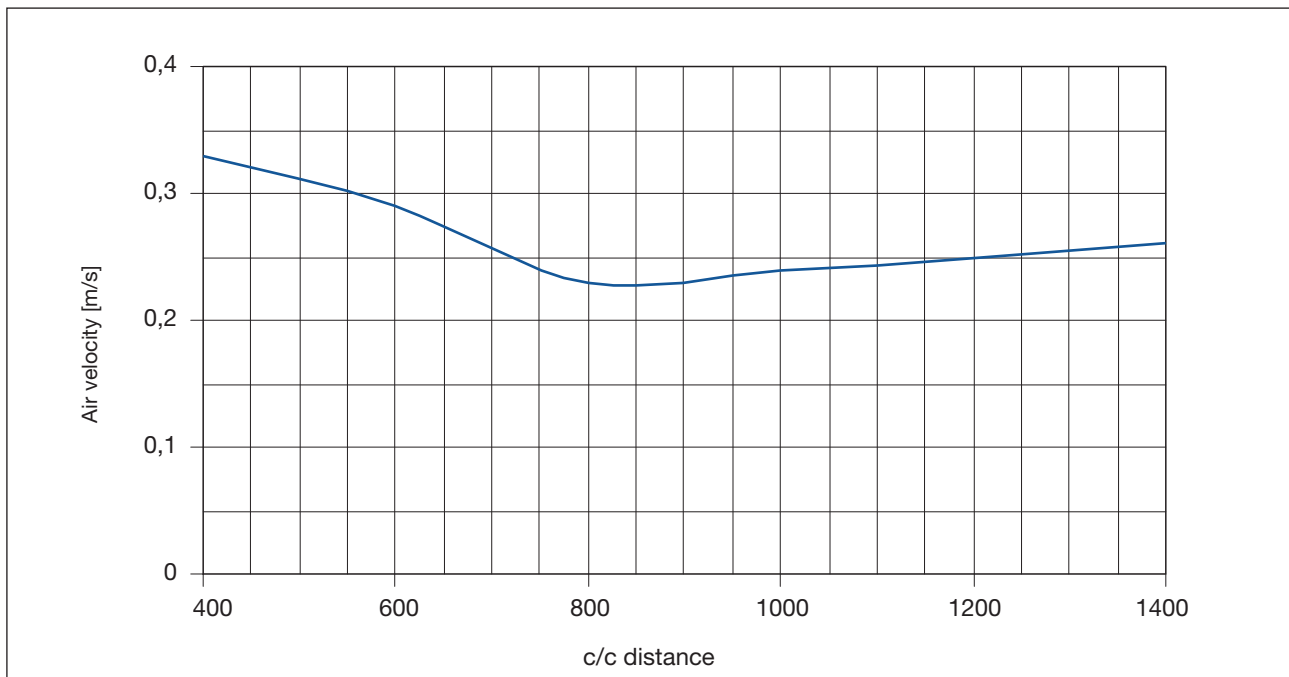

Diagram 5. Air velocity at different c-c distances between two beams. Battery beam: 110 W/m. Strip beam: 175 W/m.

Chilled ceiling guide, passive beams

Figure 5 shows what happens when a third chilled beam is installed next to the two previous ones at the minimum acceptable centre-to-centre distance of 800 mm. All air streams affect each other, but air velocities are only negligibly higher than for a single beam.

Hence, the recommendation for installing many beams next to each other is that the effect should not exceed 110 W/m and the centre-to-centre distance between the beams should be greater than 800 mm. The same applies to strip beams, but the effect can be increased to 175 W/m there.

Air velocity when beam is installed near wall

Figure 6 shows what happens when a chilled beam is installed closed to a wall. The different pressures that arise because of the air velocities cause the air stream to be sucked in towards the wall, the so-called Coanda effect. This is because the distance becomes so small that air cannot pass between the chilled beam and the wall in sufficient quantities. The phenomenon occurs at a distance of approx. 400 mm between the side edge of the beam and the wall. The width of the beam, in this case, is 420 mm. It is also clear that air velocities tend to increase when the beam is placed immediately next to the wall.

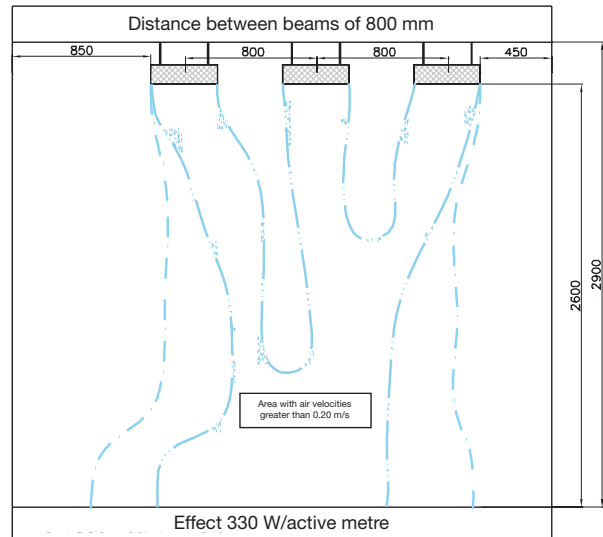
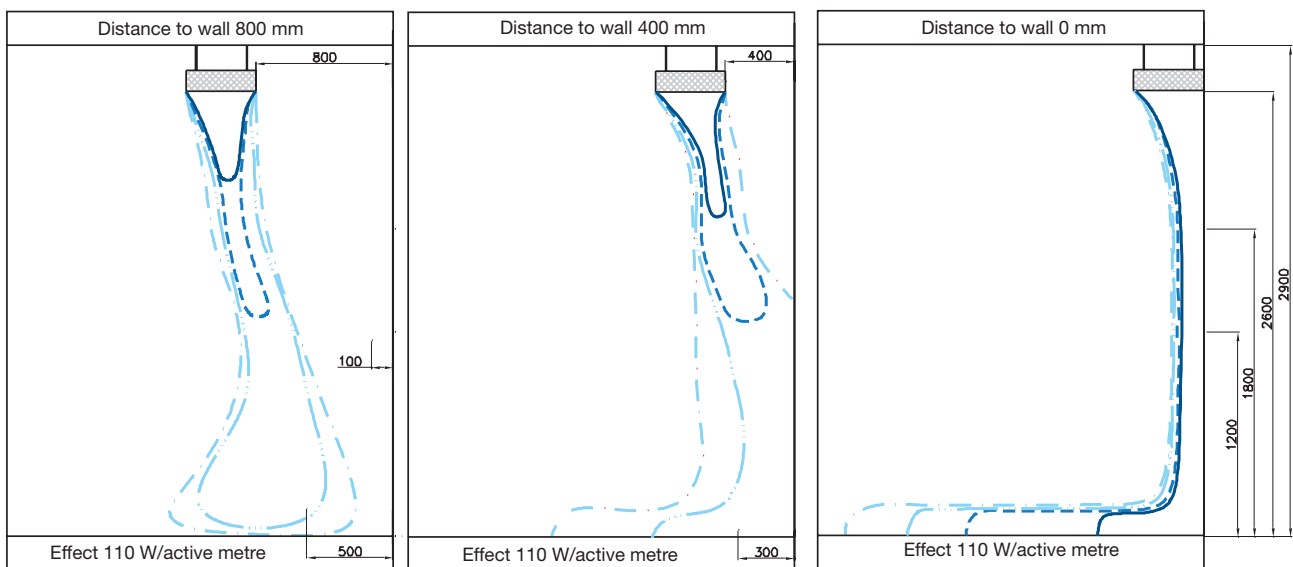

Figure 5. Air velocity with three beams.



Ceiling height: 2.9 m
 Distance to bottom edge of beam: 2.6 m
 Measuring points, air velocity: 0.1, 1.2 and 1.8

Figure 6. Air velocity when placing a beam next to wall.

Chilled ceiling guide, passive beams

Measurements & calculations

Influence of beam inclination on the air velocity

Figure 7 shows that the air velocities increase somewhat if a chilled beam is tilted lengthwise. The increase is noticeable first at an inclination of 20°C. At an inclination of 30°C, the air velocities are significantly higher and are displaced towards the lower part of the chilled beam.

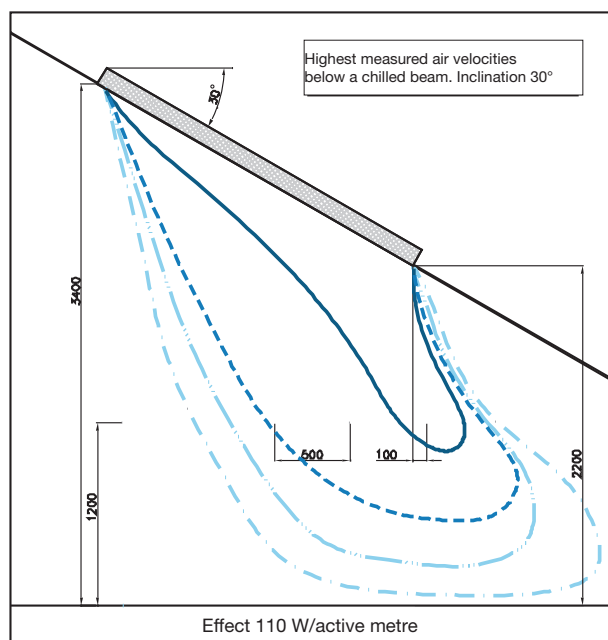
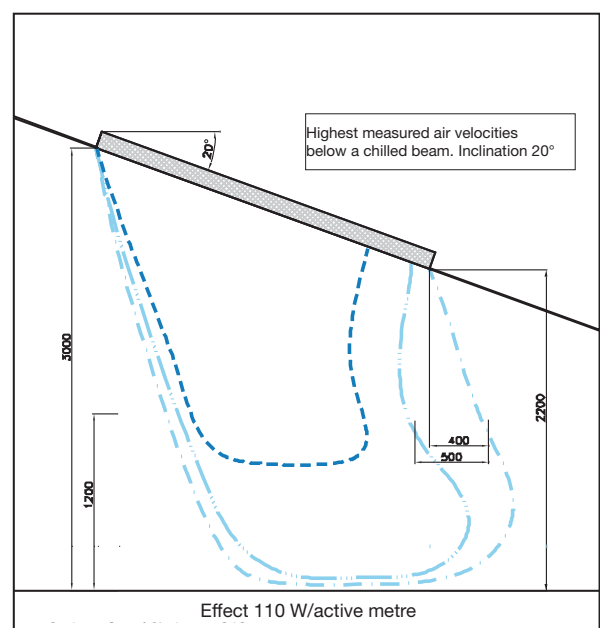
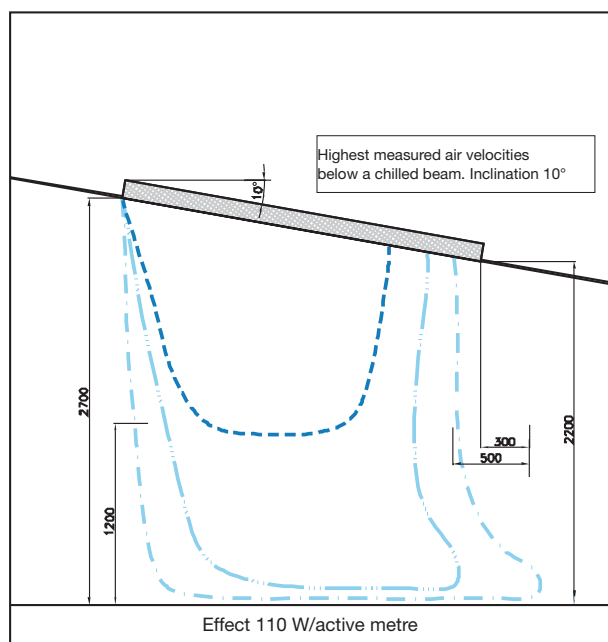

Figure 7. Air velocity at different inclinations.

Chilled ceiling guide, passive beams

Turbulence intensity in the air jet below a natural convection beam

The turbulence intensity in the air jet underneath a natural convection beam does not differ, whether it is a strip beam or a battery beam. However, the turbulence intensity depends on the velocity of the air jet. The turbulence intensity can be read off from the diagram below, as a function of different velocities. Should conditions at critical velocities be studied (approx. 0.25 m/s), the turbulence intensity is approx. 15%.

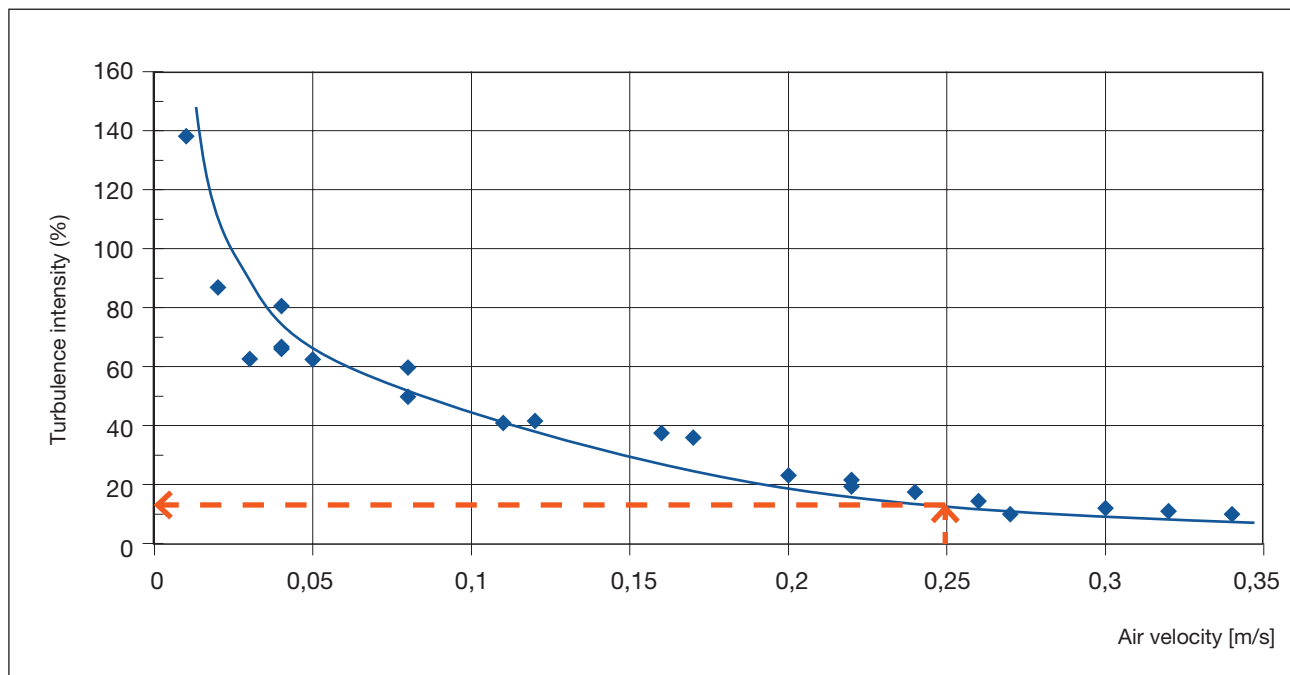

Diagram 6. Turbulence intensity, battery 42. Effect of 100 to 150 W/active metre.

Chilled ceiling guide, passive beams

Measurements & calculations

Actual case

Natural convection products are to be installed in an office with a ceiling height of 2.9 m and distance to the bottom edge of the beam of 2.6 m. The temperature requirement is a maximum of 25°C in the room, and the experience of the climate must be kept within the DIN standard for temperature, air velocity and turbulence intensity. The cooling effect provided by the product must be 500 W in total.

Check that the air velocity does not create a draught, when you select the natural convection products that meet the specified requirements.

Solution

Step 1: Use the DIN diagram, diagram 1, with 25°C and assume 15% turbulence intensity. This gives an air velocity of 0.25 m/s.

Step 2: Check the assumption in diagram 6. Enter 0.25 m/s and read off 15%. The assumption in this case is OK!

Step 3: Find out the maximum cooling effect for the strip and battery products, respectively. Go to diagram 3. The diagram gives the following values:

Strip product: 175 W/m

Battery product: 110 W/m

Check: Check whether the width of the beam has any effect on the effect in W/active metre of beam on diagram 4. The check gives the result that the width only makes a marginal difference.

Check whether the ceiling height is of any importance for the air velocity and distribution pattern for the actual ceiling height on figure 3. Since the ceiling height is within the range of 2.6 to 3.0 m above floor level, the air velocities become acceptable.

Determine the distance that is required between the two beams, in the case where two products are required, see figure 4. The figure shows that the centre-to-centre distance between the products should be at least 800 mm, for the air velocities and distribution patterns to be OK.

Check in figure 6 what the air velocities will be if the beam is placed next to or adjacent to a wall. With a distance of 400 mm or more between wall and beam, the air will not move along the wall.

Then, following steps 1 through 3, make the following choices: When selecting a strip beam: the product must be at least 500 W/175 W \approx 2.9 m long.

When selecting a battery product: the product must be at least 500 W/110 W \approx 4.5 m long.

Chilled ceiling guide, passive beams

Summary of the diagrams

Diagrams 1 + 6 indicate the permitted air velocity as a function of room temperature, see diagram 7.

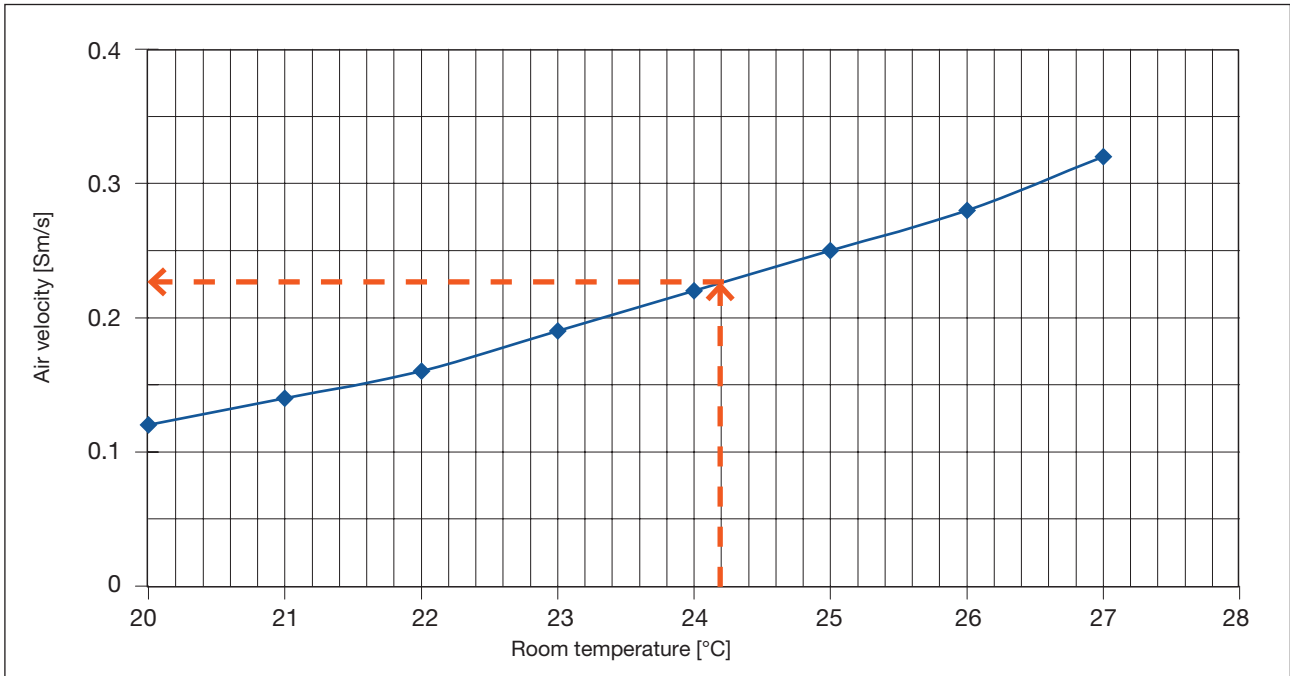

Diagram 7.

Diagrams 1 + 3 + 6 indicate the permitted effect per beam metre as a function of room temperature, see diagram 8.

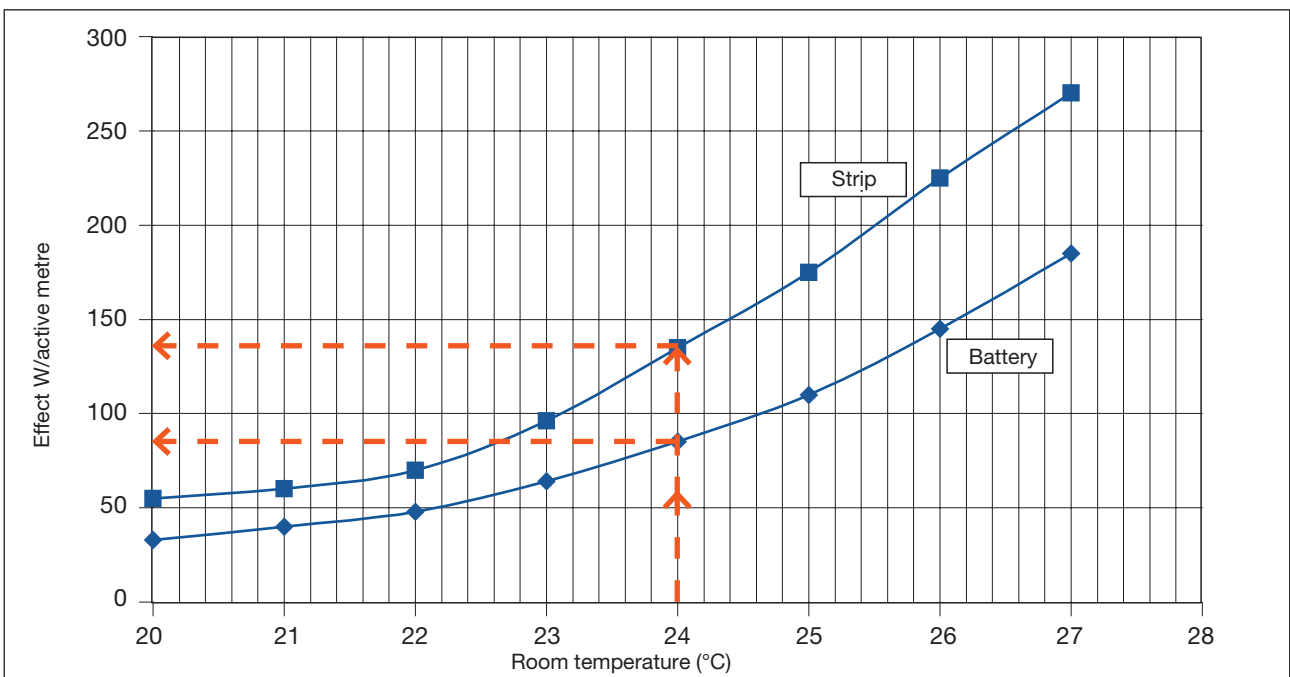

Diagram 8.



Most of us spend the majority of our time indoors. Indoor climate is crucial to how we feel, how productive we are and if we stay healthy.

We at Lindab have therefore made it our most important objective to contribute to an indoor climate that improves people's lives. We do this by developing energy-efficient ventilation solutions and durable building products. We also aim to contribute to a better climate for our planet by working in a way that is sustainable for both people and the environment.

[Lindab | For a better climate](#)