



## **FBC** 1-4-7

Technical Manual  
Installation type with fire resistance class  
English  
FIRE DAMPER  
CIRCULAR SERIES FBC1 - 4 - 7 - 300 Pa  
Cert. N° 1812-CPR-1630 - 1812-CPR-1632 - 1812-CPR-1634





<b>1. Overview</b>	<b>p. 4</b>
1.1. Description	p. 4
1.2. General characteristics	p. 4
1.3. European Standards applied	p. 4
1.4. Certifications and approvals	p. 4
1.5. Components	p. 4
1.6. Available dimensions	p. 4
1.7. Performances	p. 4
1.8. Fire resistance classification according to EN 13501-3-2009	p. 5
1.9. Mechanism type	p. 8
<b>2. Technical data</b>	<b>p. 10</b>
2.1. Dimension	p. 10
2.2. Weights	p. 10
<b>3. Installation</b>	<b>p. 11</b>
3.1. Intended use	p. 11
3.2. Not allowed uses	p. 11
3.3. Blade rotation axis positioning	p. 11
3.4. Installation of flexible connectors in order to balance out the ventilation ducts expansion	p. 11
3.5. Minimum distances	p. 12
3.6. Construction supports characteristics	p. 13
3.7. Installations within vertical rigid wall	p. 15
3.8. Installations within vertical light wall (plasterboard)	p. 26
3.9. Vertical gypsum block wall installation (carreaux de plâtre)	p. 37
3.10. Lightweight vertical security wall installations (plasterboard) - (Firewall / Brandwände)	p. 48
3.11. Installations within floor	p. 59
3.12. Installations within vertical wall with Fire Batt (Weichschott) sealing	p. 63
3.13. Installation within floor with Fire Batt (Weichschott) sealing	p. 65
<b>4. Electrical connections</b>	<b>p. 67</b>
4.1. Electrical wiring	p. 67
<b>5. Maintenance and inspections</b>	<b>p. 68</b>
5.1. Periodic inspection and cleaning	p. 68
5.2. Repair	p. 68
5.3. Disposal	p. 68
<b>6. Selection</b>	<b>p. 69</b>
6.1. Air flow rates in relation to the diameter	p. 69
6.2. Air flow rates as a function of the pressure drop	p. 69
6.3. Air flow rates as a function of generated sound levels	p. 69
6.4. Pressure drop and sound level graph	p. 70
6.5. Sound spectrum table	p. 71
<b>7. Accessories and spare parts</b>	<b>p. 72</b>
<b>8. How to order</b>	<b>p. 73</b>
<b>9. Specification Text</b>	<b>p. 74</b>
9.1. Circular fire damper series FBC Butterfly	p. 74
<b>10. Revision Index</b>	<b>p. 75</b>

# 1. OVERVIEW

## 1.1. Description

Fire dampers FBC are devices for use in heating, ventilation and air-conditioning (HVAC) systems at fire boundaries to maintain compartmentation and protect escape routes in case of fire. They satisfy integrity, insulation and smoke leakage criteria for the declared time of fire resistance. Tested and classified in accordance with EN 1366-2 and EN 13501-3 standards with 300 Pa depression.

## 1.2. General characteristics

- Casing made from galvanized carbon steel.
- Air duct connection gasket.
- Intumescent sealing gasket.
- Automated closing mechanism.
- 10 mm thick closing blade made with refractory material.
- Blade lip seal for cold smoke seal.

## 1.3. European Standards applied

CE certification	EN 15650
Test	EN 1366-2
Classification	EN 13501-3
Thermal fuse reliability	ISO 10294-4

## 1.4. Certifications and approvals

CE Certificate of Constancy of Performance	FBC1: n° 1812-CPR-1630 FBC4: n° 1812-CPR-1632 FBC7: n° 1812-CPR-1634	Efectis
--	--	---------

## 1.5. Components

1. Casing made from galvanized carbon steel.
2. Air duct connection gasket.
3. Intumescent graphite gasket on the outside the casing
4. Intumescent graphite gasket on the inside the casing
5. Damper blade made from refractoring material
6. Gasket for sealing between semi-blades
7. Cold smoke air seal gasket
8. Microswitch - on request
9. Thermal fuse fixing spring
10. Fixing blade spring on the casing
11. Blade closing spring
12. Temperature controlled closing device (thermal fuse)

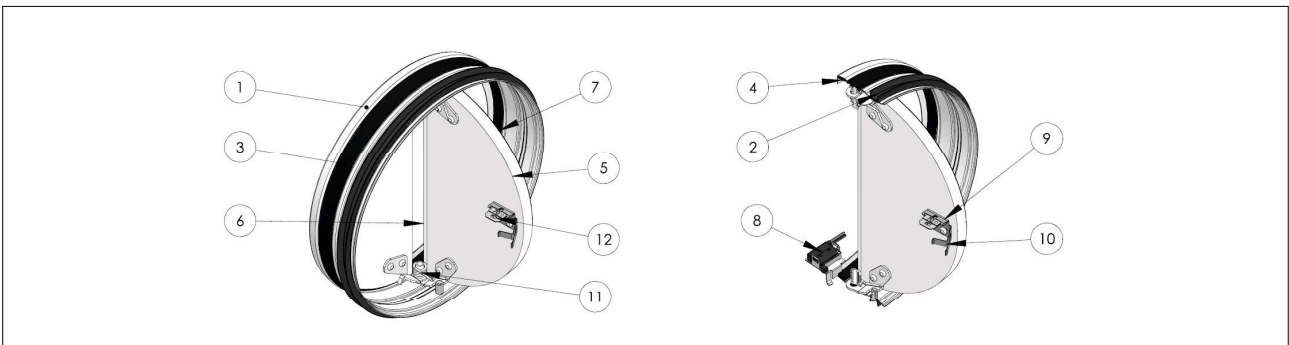

## 1.6. Available dimensions

Ø	mm	100	125	160	200
---	----	-----	-----	-----	-----

## 1.7. Performances

Performance	Reference standard	Class
Thermal fuse testing	ISO 10294-4	Compliant



1.8. Fire resistance classification according to EN 13501-3-2009

**VERTICAL RIGID WALL** min. thickness 100mm  
min. density 550Kg/m<sup>3</sup>



PRESSURE 300Pa



AXIS  
IRRELEVANT

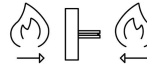

FIRE DIRECTION  
(i ↔ o)

TYPE OF INSTALLATION		TYPE OF HOLE	SEALING AND DESCRIPTION	FBC1 (60 min)	FBC4 (90 min)	FBC7 (120 min)	PAG
IN	 INSIDE THE WALL, DUCTED BOTH SIDES	SQUARE HOLE b: Ø + 50 h: Ø + 50	MORTAR OR PLASTER PUTTY	EI 60 S	EI 90 S	EI 120 S	<a href="#">p. 15</a>
			ROCK WOOL WITH MORTAR OR PLASTER OF COVERAGE	EI 60 S	EI 90 S	EI 120 S	<a href="#">p. 17</a>
			ROCK WOOL WITH PLASTERBOARD OR PROMATECT 100	EI 60 S	EI 90 S	EI 120 S	<a href="#">p. 18</a>
IN	 INSIDE THE WALL, DUCTED ONE SIDE	CIRCULAR HOLE Ø + 50	MORTAR OR PLASTER PUTTY	EI 60 S	EI 90 S	EI 120 S	<a href="#">p. 20</a>
			ROCK WOOL WITH MORTAR OR PLASTER OF COVERAGE	EI 60 S	EI 90 S	EI 120 S	<a href="#">p. 22</a>
IN	 INSIDE THE WALL, TRANSFER	SQUARE HOLE min. 600 X 600	ROCK WOOL WITH PLASTERBOARD OR PROMATECT 100	EI 60 S	EI 90 S	EI 120 S	<a href="#">p. 23</a>
			FIRE BATT (WEICHSCHOTT)	EI 60 S	EI 90 S	EI 120 S	<a href="#">p. 63</a>
			WET METHOD SEALING			DRY SEALING	

**VERTICAL LIGHT WALL** min. thickness 100mm



PRESSURE 300Pa



AXIS  
IRRELEVANT

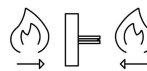

FIRE DIRECTION  
(i ↔ o)

TYPE OF INSTALLATION		TYPE OF HOLE	SEALING AND DESCRIPTION	FBC1 (60 min)	FBC4 (90 min)	FBC7 (120 min)	PAG
IN	 INSIDE THE WALL, DUCTED BOTH SIDES	SQUARE HOLE b: Ø + 50 h: Ø + 50	MORTAR OR PLASTER PUTTY	EI 60 S	EI 90 S	EI 120 S	<a href="#">p. 26</a>
			ROCK WOOL WITH MORTAR OR PLASTER OF COVERAGE	EI 60 S	EI 90 S	EI 120 S	<a href="#">p. 28</a>
			ROCK WOOL WITH PLASTERBOARD OR PROMATECT 100	EI 60 S	EI 90 S	EI 120 S	<a href="#">p. 29</a>
IN	 INSIDE THE WALL, DUCTED ONE SIDE	CIRCULAR HOLE Ø + 50	MORTAR OR PLASTER PUTTY	EI 60 S	EI 90 S	EI 120 S	<a href="#">p. 31</a>
			ROCK WOOL WITH MORTAR OR PLASTER OF COVERAGE	EI 60 S	EI 90 S	EI 120 S	<a href="#">p. 33</a>
IN	 INSIDE THE WALL, TRANSFER	SQUARE HOLE min. 600 X 600	ROCK WOOL WITH PLASTERBOARD OR PROMATECT 100	EI 60 S	EI 90 S	EI 120 S	<a href="#">p. 34</a>
			FIRE BATT (WEICHSCHOTT)	EI 60 S	EI 90 S	EI 120 S	<a href="#">p. 63</a>
			WET METHOD SEALING			DRY SEALING	

**VERTICAL PLASTER BLOCKS WALL (CARREAUX PLATRE)**

min. thickness 100mm



PRESSURE 300Pa



AXIS  
IRRELEVANT

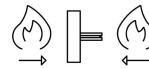

FIRE DIRECTION  
(i ↔ o)

TYPE OF INSTALLATION		TYPE OF HOLE	SEALING AND DESCRIPTION	FBC1 (60 min)	FBC4 (90 min)	FBC7 (120 min)	PAG
IN		SQUARE HOLE b: $\varnothing + 50$ h: $\varnothing + 50$	MORTAR OR PLASTER PUTTY	EI 60 S	EI 90 S	EI 120 S	<a href="#">p. 37</a>
			ROCK WOOL WITH MORTAR OR PLASTER OF COVERAGE	EI 60 S	EI 90 S	EI 120 S	<a href="#">p. 39</a>
			ROCK WOOL WITH PLASTERBOARD OR PROMATECT 100	EI 60 S	EI 90 S	EI 120 S	<a href="#">p. 40</a>
IN		CIRCULAR HOLE $\varnothing + 50$	MORTAR OR PLASTER PUTTY	EI 60 S	EI 90 S	EI 120 S	<a href="#">p. 42</a>
			ROCK WOOL WITH MORTAR OR PLASTER OF COVERAGE	EI 60 S	EI 90 S	EI 120 S	<a href="#">p. 44</a>
IN		SQUARE HOLE min. 600 X 600	ROCK WOOL WITH PLASTERBOARD OR PROMATECT 100	EI 60 S	EI 90 S	EI 120 S	<a href="#">p. 45</a>
			FIRE BATT (WEICHSCHOTT)	EI 60 S	EI 90 S	EI 120 S	<a href="#">p. 63</a>
			WET METHOD SEALING			DRY SEALING	

**VERTICAL SAFETY LIGHT WALL (BRANDWADE)**

min. thickness 100mm



PRESSURE 300Pa



AXIS  
IRRELEVANT

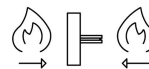

FIRE DIRECTION  
(i ↔ o)

TYPE OF INSTALLATION		TYPE OF HOLE	SEALING AND DESCRIPTION	FBC1 (60 min)	FBC4 (90 min)	FBC7 (120 min)	PAG
IN		SQUARE HOLE b: $\varnothing + 50$ h: $\varnothing + 50$	MORTAR OR PLASTER PUTTY	EI 60 S	EI 90 S	EI 120 S	<a href="#">p. 48</a>
			ROCK WOOL WITH MORTAR OR PLASTER OF COVERAGE	EI 60 S	EI 90 S	EI 120 S	<a href="#">p. 50</a>
			ROCK WOOL WITH PLASTERBOARD OR PROMATECT 100	EI 60 S	EI 90 S	EI 120 S	<a href="#">p. 51</a>
IN		CIRCULAR HOLE $\varnothing + 50$	MORTAR OR PLASTER PUTTY	EI 60 S	EI 90 S	EI 120 S	<a href="#">p. 53</a>
			ROCK WOOL WITH MORTAR OR PLASTER OF COVERAGE	EI 60 S	EI 90 S	EI 120 S	<a href="#">p. 55</a>
IN		SQUARE HOLE min. 600 X 600	ROCK WOOL WITH PLASTERBOARD OR PROMATECT 100	EI 60 S	EI 90 S	EI 120 S	<a href="#">p. 56</a>
			FIRE BATT (WEICHSCHOTT)	EI 60 S	EI 90 S	EI 120 S	<a href="#">p. 63</a>
			WET METHOD SEALING			DRY SEALING	

FLOOR

min. thickness 150 mm



PRESSURE 300Pa



AXIS  
IRRELEVANT

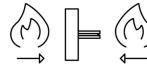

FIRE DIRECTION  
(i ↔ o)

TYPE OF INSTALLATION		TYPE OF HOLE	SEALING AND DESCRIPTION	FBC1 (60 min)	FBC4 (90 min)	FBC7 (120 min)	PAG
IN	 INSIDE THE WALL, DUCTED BOTH SIDES	SQUARE HOLE b: $\varnothing + 50$ h: $\varnothing + 50$	 MORTAR OR PLASTER PUTTY	EI 60 S	EI 90 S	EI 120 S	<a href="#">p. 59</a>
IN	 INSIDE THE WALL, DUCTED ONE SIDE	CIRCULAR HOLE $\varnothing + 50$	 MORTAR OR PLASTER PUTTY	EI 60 S	EI 90 S	EI 120 S	<a href="#">p. 61</a>
IN	 INSIDE THE WALL, TRANSFER	SQUARE HOLE min. 600 X 600	 FIRE BATT (WEICHSCHOTT)	EI 60 S	EI 90 S	EI 120 S	<a href="#">p. 65</a>
				WET METHOD SEALING			

Cert. N° FBC1 1812-CPR-1630,FBC4 1812-CPR-1632,FBC7 1812-CPR-1634

## 1.9. Mechanism type

### 1.9.1. Manual

#### Blade closing mode

Automatic closing with thermal fuse.

The control mechanism has a thermosensitive element that automatically closes the blade when the temperature in the duct exceeds 70°C.

The damper can be closed manually as per the following instructions.

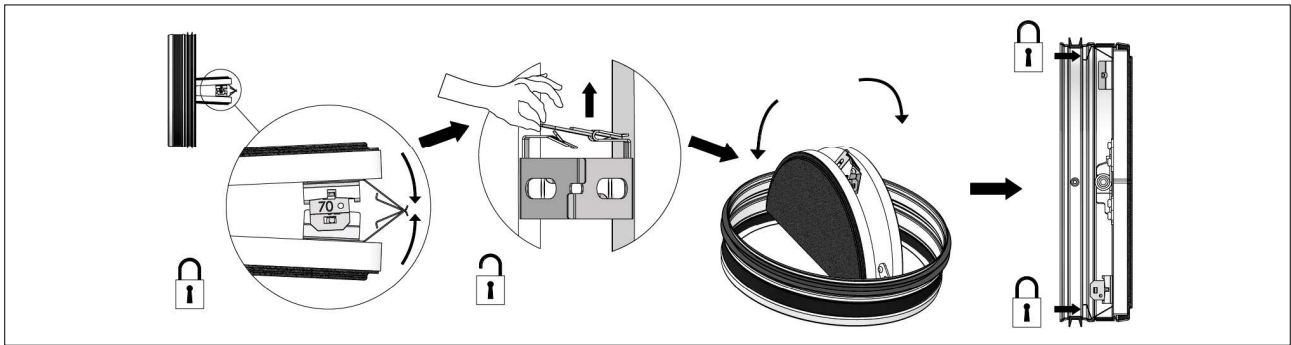

The fire damper is equipped with a spring for closing the blade: pay attention to the hands.

#### Blade opening mode

Make sure that the damper is open before the ventilation system start-up, otherwise there is a risk of product malfunction. In case of closed damper as a result of the action of the thermosensitive element, it is possible to manually reopen the damper once the thermosensitive element has been replaced.

The fire damper can be opened manually as per the following instructions.

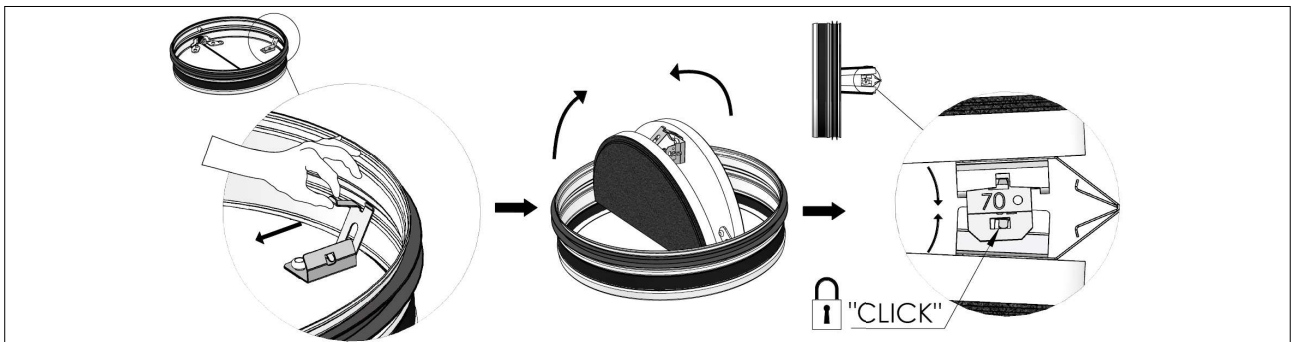

The fire damper is equipped with a spring for closing the blade: pay attention to the hands.

#### Position indication microswitch

On request, the fire damper can be equipped with a position microswitch (see section Accessories and spare parts) that signals the closed blade position. See section Electrical connections for more details.

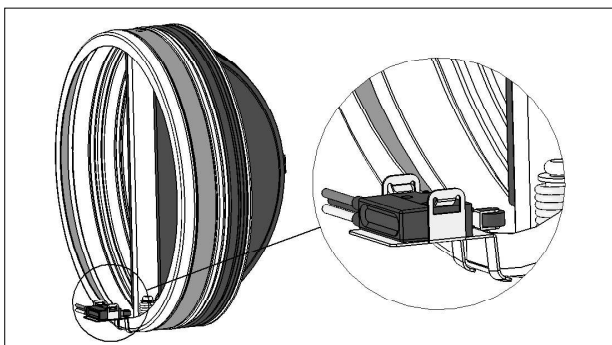

#### Temperature calibration of thermosensitive element for automatic damper closing

70 °C±7 °C

**1.9.2.** Closing by remote control

Not available

**1.9.3.** Motorized version

Not available

## 2. TECHNICAL DATA

The sizes shown are in mm.

### 2.1. Dimension

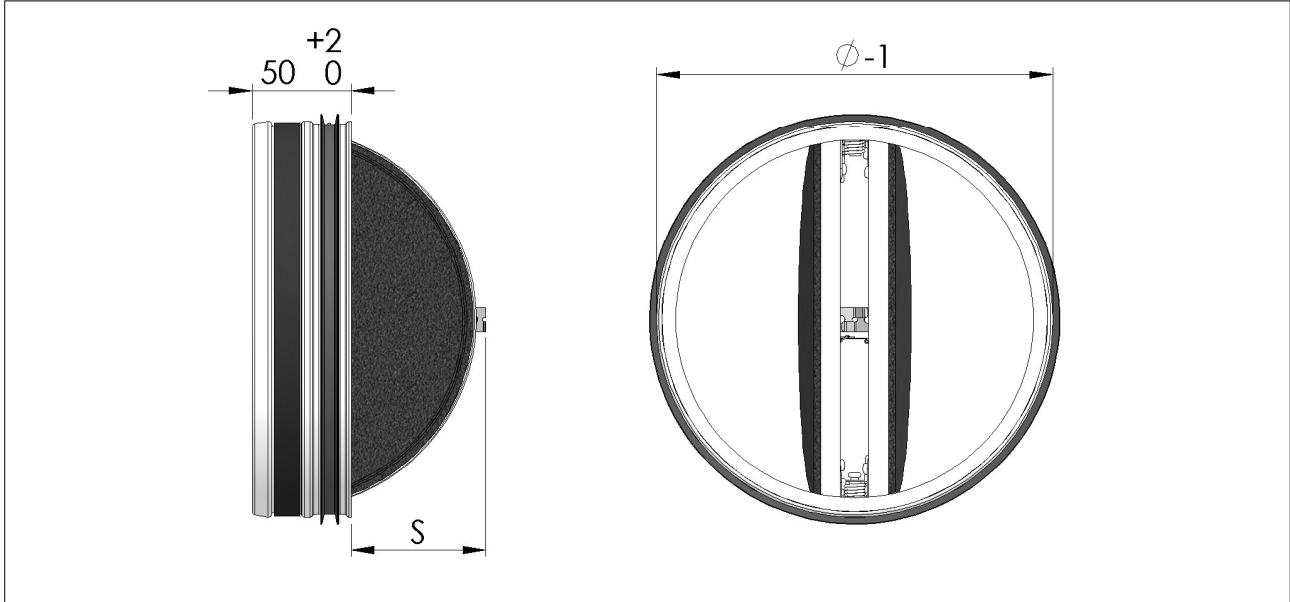

Ø	mm	100	125	160	200
S blade exposition	mm	21	34	51	72

### 2.2. Weights

Ø	mm	100	125	160	200
Weight	kg	0,3	0,4	0,5	0,9

### 3. INSTALLATION

The sizes shown are in mm.

It is recommended to perform a functional test before Installation to exclude possible damage during transport.

The fire dampers FBC must be accessible for maintenance and inspections.

#### 3.1. Intended use

The MP3 fire dampers are "Devices for use in heating, ventilation and air conditioning (HVAC) systems at fire boundaries to maintain compartmentation and protect escape routes in case of fire" according to the 3.1 paragraph of EN 15650:2010 standard.

It is compulsory to install the fire damper according to the instructions indicated in the technical data sheet and manual to maintain the declared performances and, in particular, the fire classes.

The double test (with the mechanism inside and outside the fire area) demonstrated that there is no preferred direction for the position of the damper, both in relation to air flow and the side with the higher probability of exposure to fire, as indicated in standard EN1366-2:2015 (paragraph 6.2).

Use permitted in any civil and industrial building.

#### 3.2. Not allowed uses

- Use with installations different to those described in the technical data sheet and manual;
- use as smoke control damper;
- use as shut off damper;
- use in explosive environments;
- use on board of ships;
- use in cooker extraction hoods;
- use in pneumatic conveying systems of dust or corn;
- use in ventilation systems within locations subject to chemical contamination;
- use in non inspectable environments;
- installation in fire resistant false ceilings crossings;
- use in ventilation ducts where condensation can occur.

#### 3.3. Blade rotation axis positioning

The fire damper can be installed with the blade axis positioned vertically or horizontally or tilted at any angle.

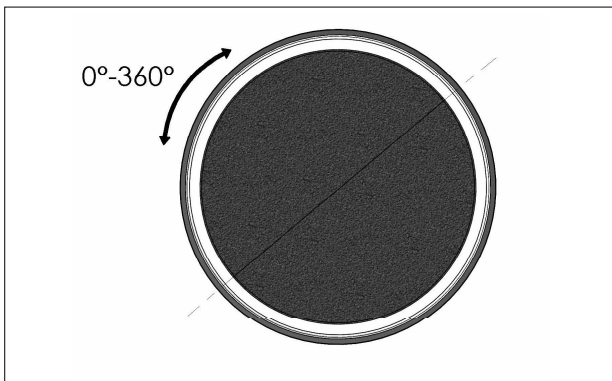

#### 3.4. Installation of flexible connectors in order to balance out the ventilation ducts expansion

**ATTENTION: the following indications must be considered binding only if legislation or local regulation where the fire dampers are installed require the use of flexible connectors.**

Flexible connectors compensate any duct thermal expansion and wall bending in case of fire.

Flexible connectors are used to limit fire damper stresses due to external forces in case of fire and to preserve fire resistance class.

In general it is always appropriate the use of flexible connectors for the followings installations:

- light walls;
- Plasterboard and rock wool or Fire Batt (Weichschott) sealing;
- Applique fixing system.

Flexible connector must be normal flammability and in case of fire the grounding bonding should disconnet to guarantee the complete separation between fire damper and connected air duct.

When flexible connectors made of conductive material (e.g. aluminum) are used, no additional grounding bonding is required.

Despite flexible connector installation, the fire damper must be installed in the construction support so that its weight does not affect damper's installation position both during normal operation and in case of fire.

It is recommended not to compress flexible connectors in the installation phase.

Flexible connector must be at least 100mm long and in order that possible duct thermal expansions are balanced. Take care that the flexible connector does not interfere with opening / closing movement of the blade.

Refer to the section Technical data for blade exposition values.

### 3.5. Minimum distances

In accordance with Articles 7 and 13 of EN 1366-2 respect the minimum distances indicated below.

#### Minimum distances

- 1. Vertical lateral wall
- 2. Floor

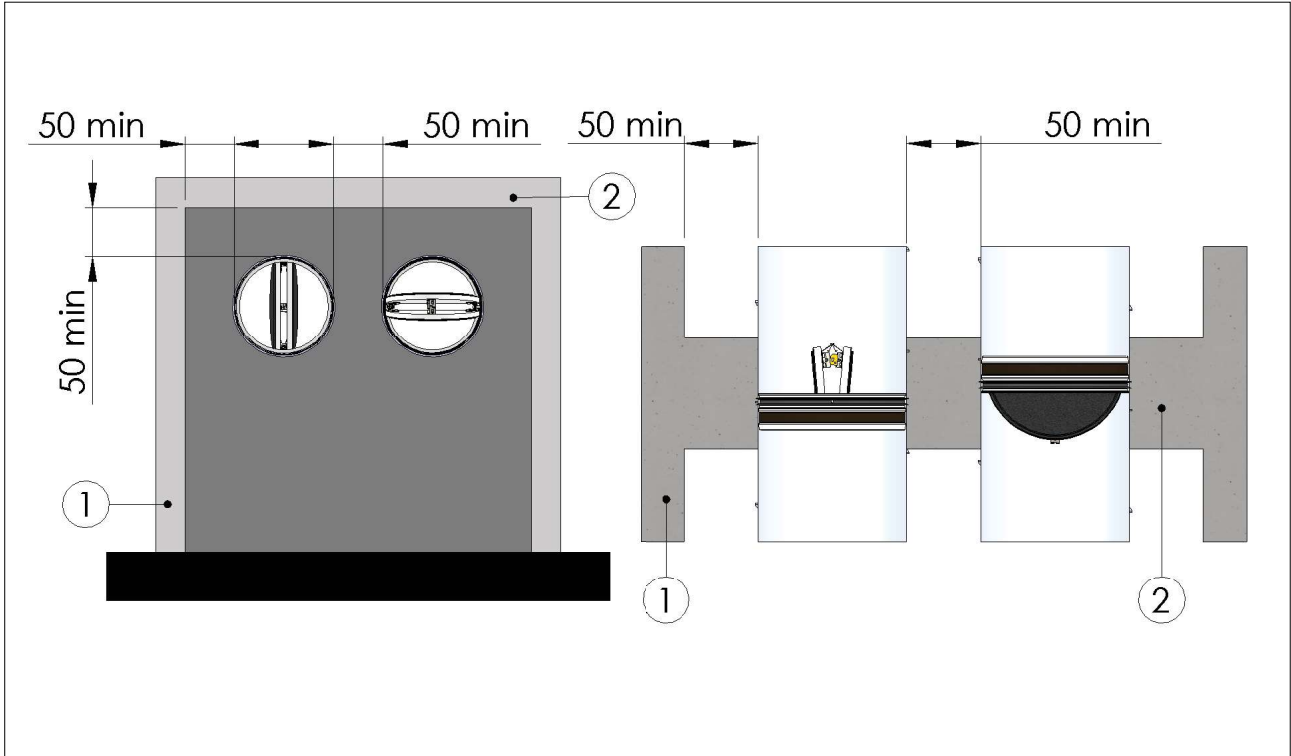



### 3.6. Construction supports characteristics

The European standard for fire dampers foresees a precise correlation between the wall/floor characteristics and the fire resistance class obtained, as well as the correlation between wall/floor used for the test and wall/floor used for the actual installation.

The test results obtained on a type of wall/floor are valid also for walls/floor of the same type but with greater thickness and/or density than those used in the test.

For plasterboard walls, the test results are also valid for walls with a greater number of plasterboard layers on each side. As a result, the indicated thickness and density characteristics are to be considered as minimum values.

The wall/floor in which the fire dampers are installed must be fire class certified according to the standards foreseen for the structure.

#### 3.6.1. Rigid walls

Can be made with aerated concrete blocks, poured concrete, concrete panels, perforated cell elements in concrete or brick in accordance with the following characteristics:

- minimum thickness 100 mm;
- minimum density 550 kg/m<sup>3</sup>.

For walls built with perforated elements, it is also recommended that the area of the opening be made from full elements (for example aerated concrete blocks) to guarantee the correct adhesion of the mortar.

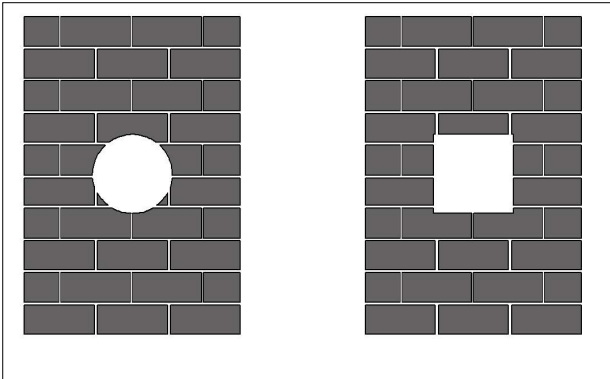

#### 3.6.2. Light plasterboard vertical walls

During testing, light plasterboard walls have been used with the following characteristics:

- U-shaped horizontal metal frame (50 mm) and C-shaped vertical frame (49 mm) made from 0,6 mm thick sheet metal;
- vertical profiles placed with a maximum spacing of 1000 mm;
- Filling made of rock wool;
- Each side is made from two plasterboard layers 12,5 mm thick, unalined to avoid alignment between the joints of the layer above and below.

The following indications are given for the installation walls:

- metal profiles minimum width: 49 mm;
- metal profiles minimum thickness: 0,6 mm;
- vertical profiles placed with a maximum spacing of 1000 mm between each other;

- vertical profile fixing with selfthreading screws or by clinching to the bottom horizontal profile and insertion in the top horizontal profile;
- profiles fixed using self-threading screws or by clinching on every intersection.
- installation of a frame around the damper with base and height where shown in the installation instructions;
- Filling made of rock wool;
- each side is made from two plasterboard layers 12,5 mm minimum thick, unalined to avoid alignment between the joints of the layer above and below.
- the front plasterboards layers are fixed using long enough screws to pass through the lower plasterboard and attach to the steel profile underneath.

1. Plasterboard thickness 12,5 mm
2. Rock wool
3. Horizontal U-shaped profile
4. Vertical C-shaped profile
5. Self-drilling screw Ø 3,5 X 25 mm
6. Self-drilling screw Ø 3,5 X 35 mm

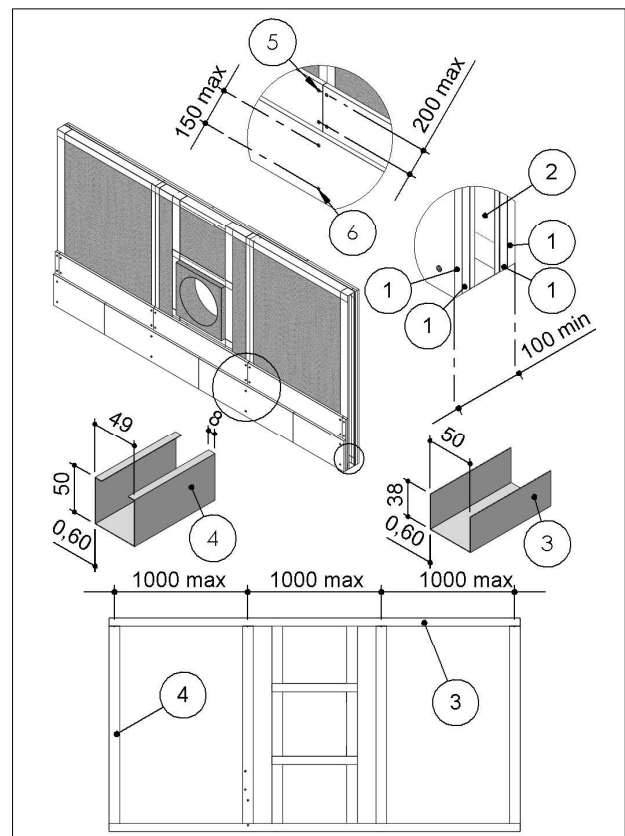

#### 3.6.3. Vertical plaster block wall (carreaux de platre)

Gypsum blocks wall can be built with special solid gypsum blocks with interlocking shaped edges as indicated in the supplier's instructions and according to the following characteristics:

- minimum thickness 70 or 100 mm according to the type and resistance class required;
- minimum density 995 kg/m<sup>3</sup>.

It is generally advisable to first build the wall and then provide the opening for the fire damper.

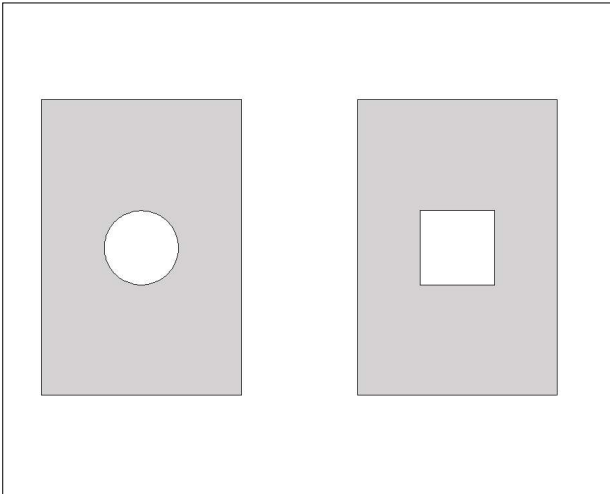

### 3.6.4. Light plasterboard vertical walls with steel reinforcement (special / firewall)

During testing, light plasterboard walls have been used with the following characteristics:

- U-shaped horizontal metal frame (50 mm) and C-shaped vertical frame (49 mm) made from 0,6 mm thick sheet metal;
- Vertical profiles placed with a maximum spacing of 312,5 mm between each other;
- reinforcement sheet;
- Filling made of rock wool with density up to 40 kg/m<sup>3</sup> (optional);
- Each side is made from two plasterboard layers 12,5 mm thick, unalined to avoid alignment between the joints of the layer above and below.

The following indications are given for the installation walls:

- metal profiles minimum width: 49 mm;
- metal profiles minimum thickness: 0,6 mm;
- vertical profiles placed with a maximum spacing of 312,5mm between each other;
- vertical profile fixing with selfthreading screws or by clinching to the bottom horizontal profile and insertion in the top horizontal profile;
- profiles fixed using self-threading screws or by clinching on every intersection.
- installation of a frame around the damper with base and height where shown in the installation instructions;
- Filling made of rock wool with density up to 100 kg/m<sup>3</sup> (optional);
- each side is made from two plasterboard layers 12,5 mm minimum thick, unalined to avoid alignment between the joints of the layer above and below.
- the front plasterboards layers are fixed using long enough screws to pass through the lower plasterboard and attach to the steel profile underneath.

1. Plasterboard thickness 12,5 mm
2. Rock wool density up to 40 kg/m<sup>3</sup> (optional)
3. Reinforcement sheet
4. Horizontal U-shaped profile
5. Vertical C-shaped profile
6. Self-drilling screw Ø 3,5 X 25 mm
7. Self-drilling screw Ø 3,5 X 35 mm

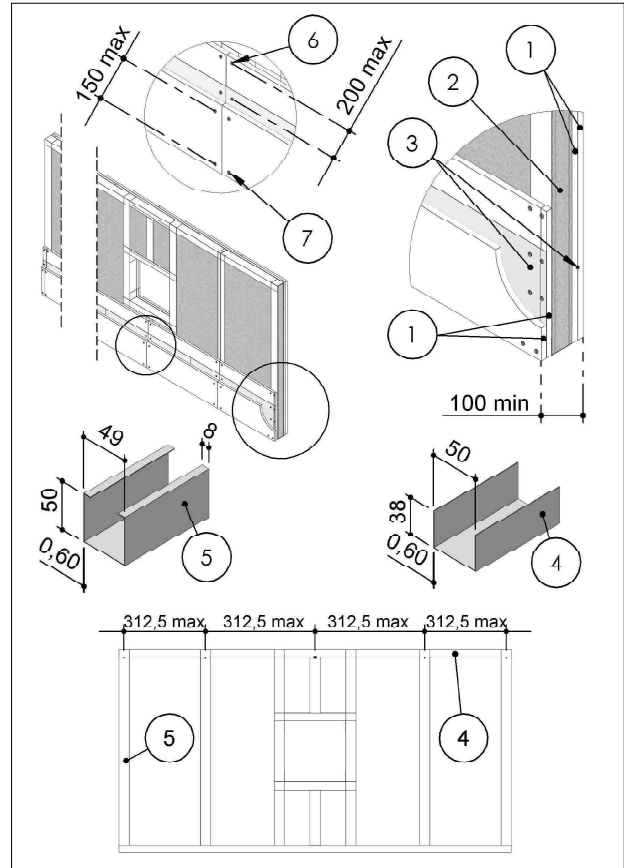

### 3.6.5. Concrete floors

Concrete floors can be built during installation or with pre-formed slabs with interlocking shaped edges or hollow bricks and concrete according to the following characteristics:

- minimum thickness 100 or 150 mm according to the type and resistance class required;
- minimum density 550 kg/m<sup>3</sup>.

### 3.7. Installations within vertical rigid wall

See section Construction supports characteristics for more details, observe the minimum distances indicated in section Minimum distances, carry out a functional test before and after installation. See section for more details.

#### 3.7.1. Wall opening

A opening must be provided in the wall as indicated in the drawing.

#### 3.7.2. Damper positioning

Install the fire damper in the ventilation duct as shown in the drawing. Close the blade before installing the fire damper

#### 3.7.3. Filling

Fill the space between ventilation duct and wall as indicated in the drawing.

#### 3.7.4. Insulation

The walls must be of the same or higher strength class than the damper.

#### Rigid wall, ducted on both sides, square hole, mortar or plaster putty

- |    |                            |    |   |
|----|----------------------------|----|---|
| 1. | Mortar or plaster grouting | 4. | Vertical rigid wall   |
| 2. | Fire damper                | D  | from nominal diameter min + 50 to nominal diameter max + 70 |
| 3. | Ventilation duct           |    |   |

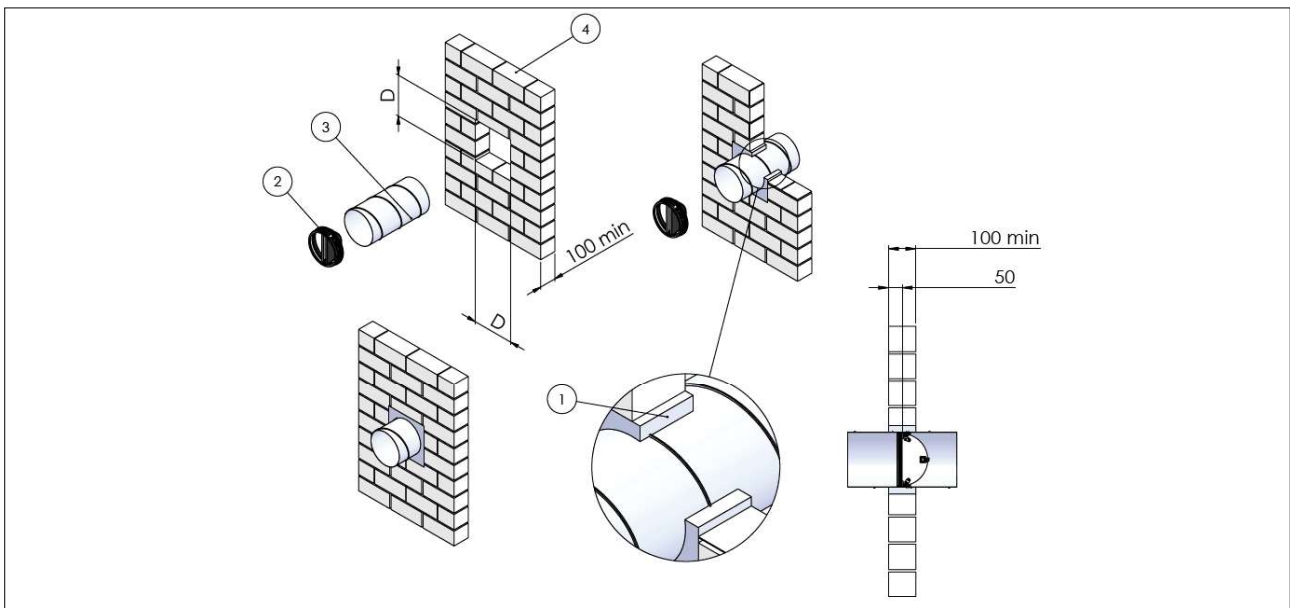

**Rigid wall, ducted on one side, square hole, mortar or plaster putty**

- |                               |   |
|-------------------------------|---|
| 1. Mortar or plaster grouting | 4. Ventilation duct   |
| 2. Terminal valve             | 5. Vertical rigid wall  |
| 3. Fire damper                | D from nominal diameter min + 50 to nominal diameter max + 70 |

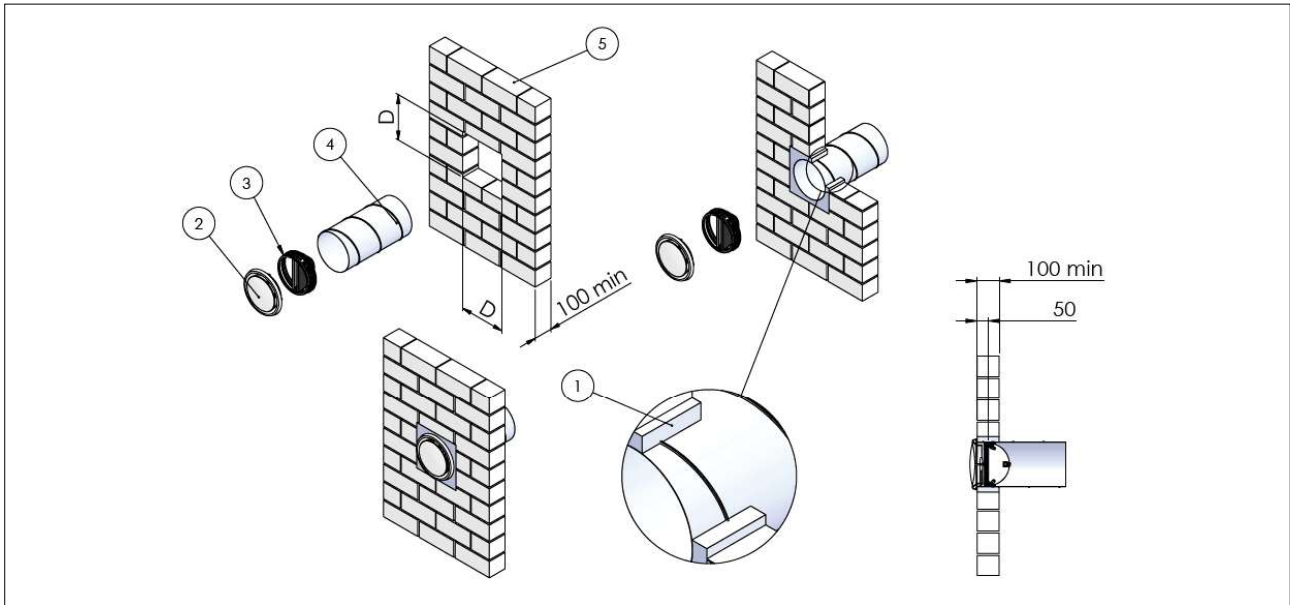

**Rigid wall, transfer, square hole, mortar or plaster putty**

- |                               |   |
|-------------------------------|---|
| 1. Mortar or plaster grouting | 4. Ventilation duct   |
| 2. Terminal valve             | 5. Vertical rigid wall  |
| 3. Fire damper                | D from nominal diameter min + 50 to nominal diameter max + 70 |

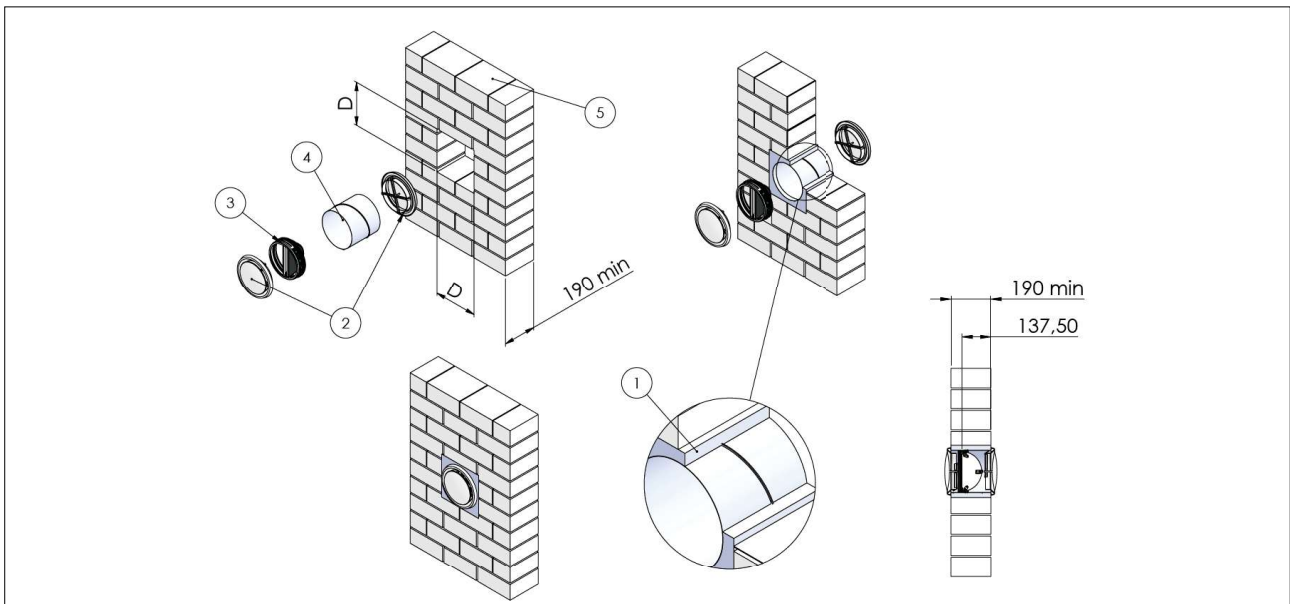

**Rigid wall, ducted on both sides, square hole, rock wool with mortar or plaster putty**

- |                                    |   |
|------------------------------------|---|
| 1. Rock wool, 40 kg/m <sup>3</sup> | 4. Ventilation duct   |
| 2. Mortar or plaster grouting      | 5. Vertical rigid wall  |
| 3. Fire damper                     | D from nominal diameter min + 50 to nominal diameter max + 70 |

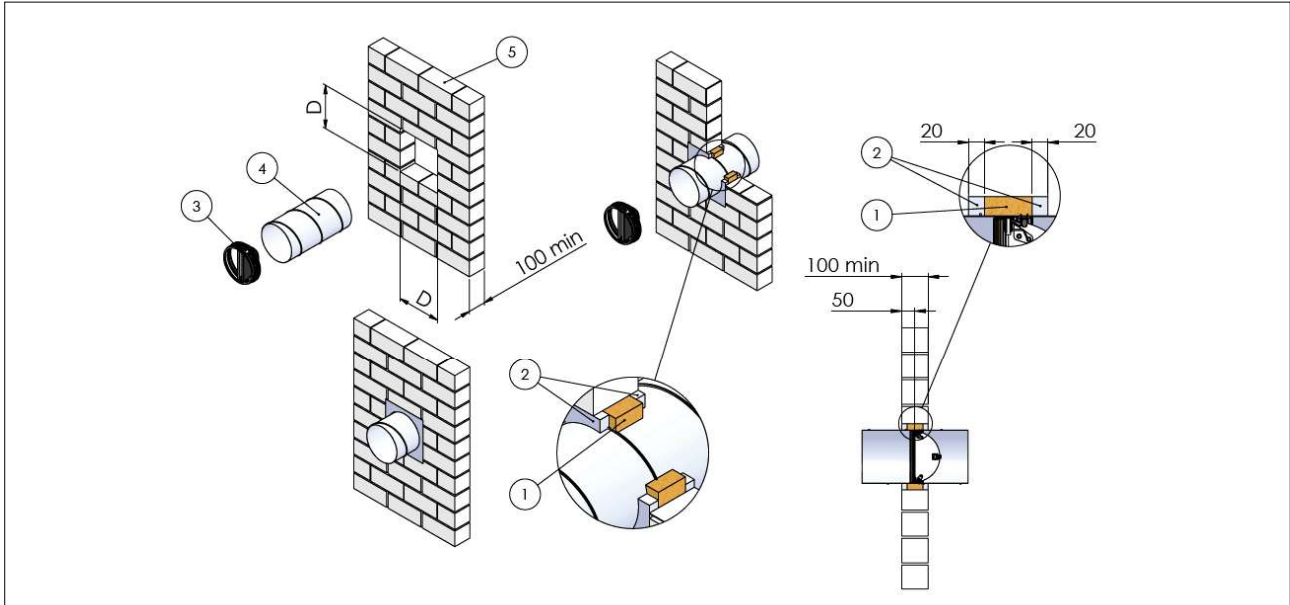

**Rigid wall, ducted on one side, square hole, rock wool with mortar or plaster putty**

- |                                    |   |
|------------------------------------|---|
| 1. Rock wool, 40 kg/m <sup>3</sup> | 5. Ventilation duct   |
| 2. Mortar or plaster grouting      | 6. Vertical rigid wall  |
| 3. Terminal valve                  | D from nominal diameter min + 50 to nominal diameter max + 70 |
| 4. Fire damper                     |   |

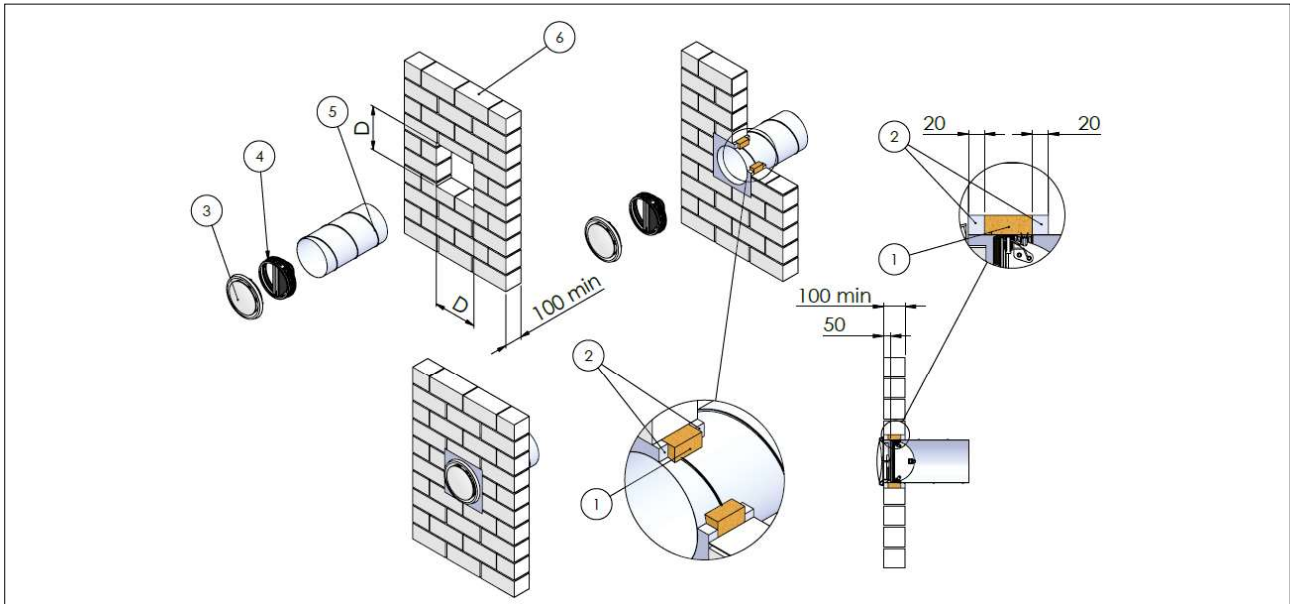



**rigid wall, transfer, square hole, rock wool with mortar or plaster putty**

- |                                    |   |
|------------------------------------|---|
| 1. Mortar or plaster grouting      | 5. Ventilation duct   |
| 2. Rock wool, 40 kg/m <sup>3</sup> | 6. Vertical rigid wall  |
| 3. Terminal valve                  | D from nominal diameter min + 50 to nominal diameter max + 70 |
| 4. Fire damper                     |   |

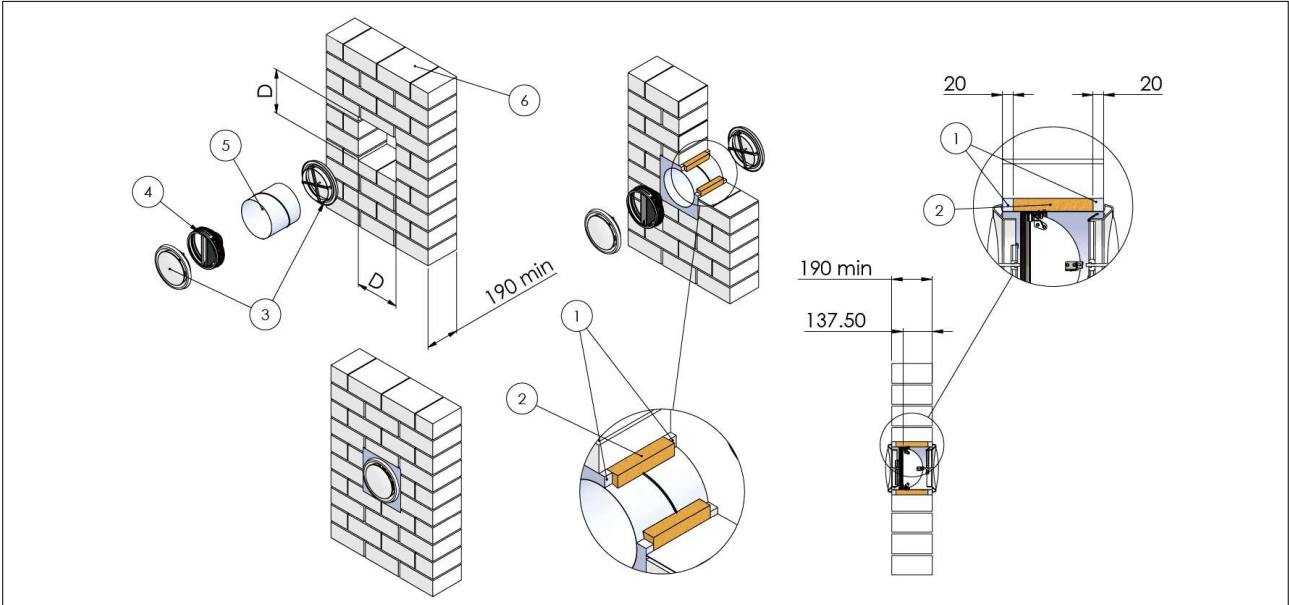

**Rigid wall, ducted both sides, square hole, rock wool plasterboard - EI60-S - FBC1**

- |                                   |   |
|-----------------------------------|---|
| 1. Rock wool 40 kg/m <sup>3</sup> | 5. Plasterboard arch infill type A, thickness 12,5 mm or promactect 100 thickness 12 mm |
| 2. Fire damper                    | 6. Self-drilling screw $\varnothing$ 3,5 X 45 mm  |
| 3. Ventilation duct               | D from nominal diameter min + 50 to nominal diameter max + 70                           |
| 4. Rigid vertical wall            |   |

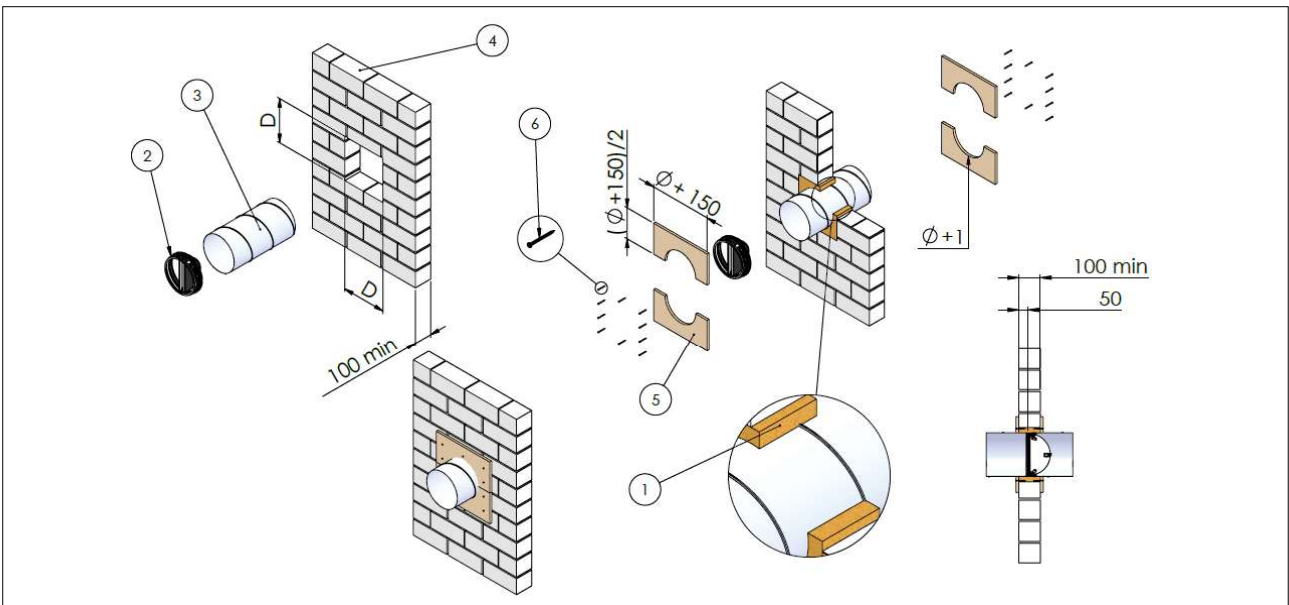

**Rigid wall, ducted both sides, square hole, rock wool plasterboard - EI90-S - FBC4- EI120-S - FBC7**

- |                                   |   |
|-----------------------------------|---|
| 1. Rock wool 40 kg/m <sup>3</sup> | 5. Plasterboards arch infill type F, thickness 12,5 mm or promatect 100 thickness 12 mm |
| 2. Fire damper                    | 6. Self-drilling screw Ø 3,5 X 45 mm  |
| 3. Ventilation duct               | D from nominal diameter min + 50 to nominal diameter max + 70                           |
| 4. Rigid vertical wall            |   |

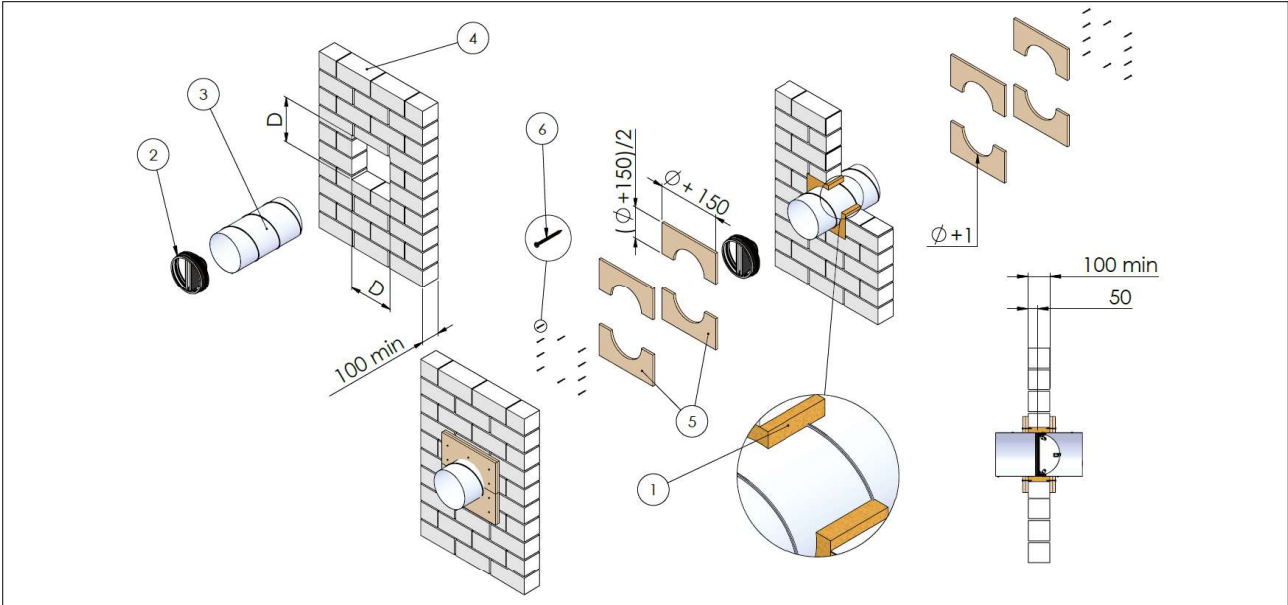

**Rigid wall, ducted one side, square hole, rock wool with plasterboard**

- |                                   |   |
|-----------------------------------|---|
| 1. Rock wool 40 kg/m <sup>3</sup> | 6. Plasterboard arch infill, thickness 12,5 mm or promatect 100 thickness 12 mm |
| 2. Terminal valve                 | 7. Self-drilling screw Ø 3,5 X 45 mm  |
| 3. Fire damper                    | D from nominal diameter min + 50 to nominal diameter max + 70                   |
| 4. Ventilation duct               |   |
| 5. Rigid vertical wall            |   |

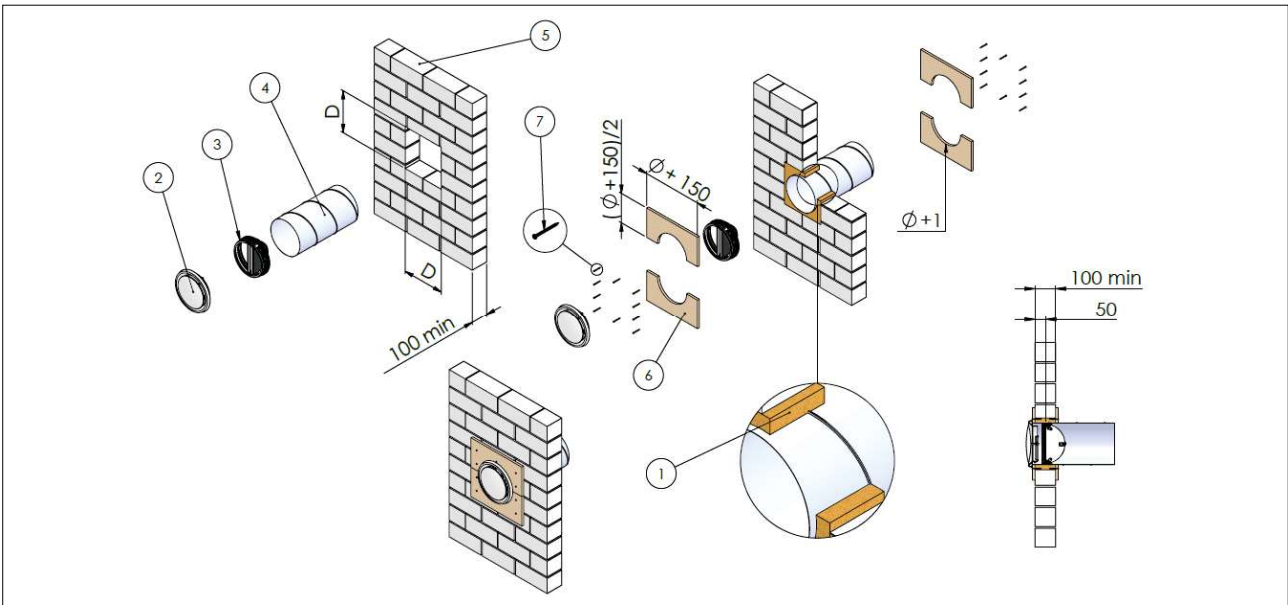

**Rigid wall, transfer, square hole, rock wool plasterboard**

- |                                   |   |
|-----------------------------------|---|
| 1. Rock wool 40 kg/m <sup>3</sup> | 6. Plasterboard arch infill, thickness 12,5 mm or promatect 100 thickness 12 mm |
| 2. Terminal valve                 | 7. Self-drilling screw Ø 3,5 X 45 mm  |
| 3. Fire damper                    | D from nominal diameter min + 50 to nominal diameter max + 70                   |
| 4. Ventilation duct               |   |
| 5. Rigid vertical wall            |   |

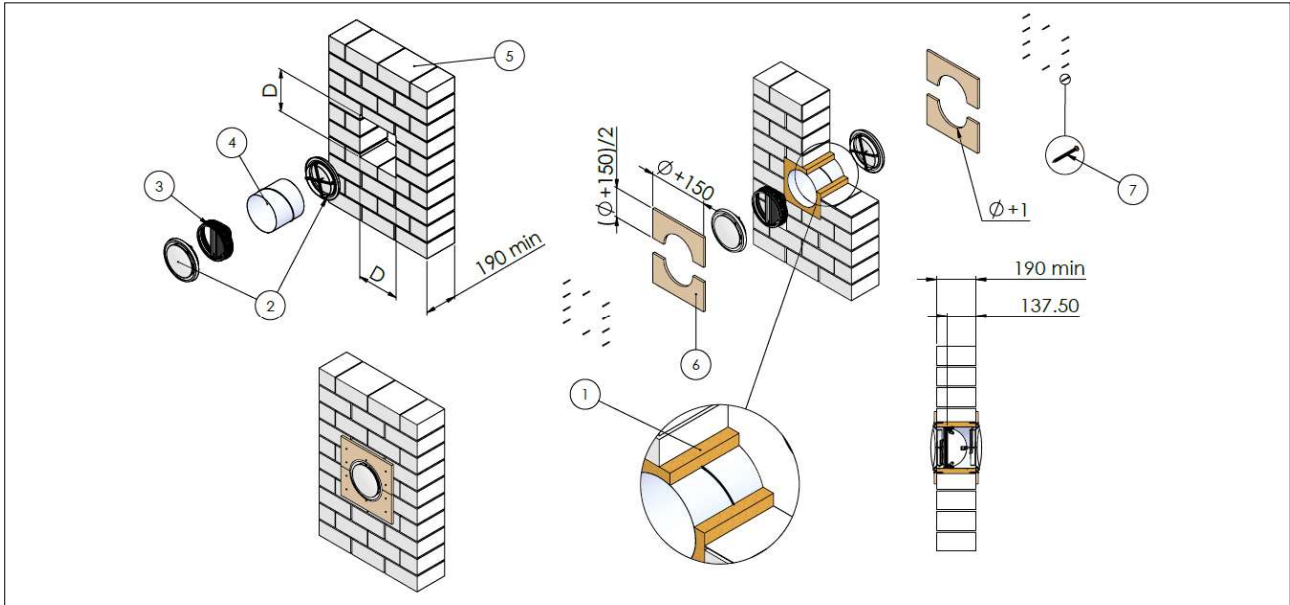

**Rigid wall, channelled both sides, circular hole, mortar or plaster putty**

- |                               |   |
|-------------------------------|---|
| 1. Mortar or plaster grouting | 4. Vertical rigid wall  |
| 2. Fire damper                | D from nominal diameter min + 50 to nominal diameter max + 70 |
| 3. Ventilation duct           |   |

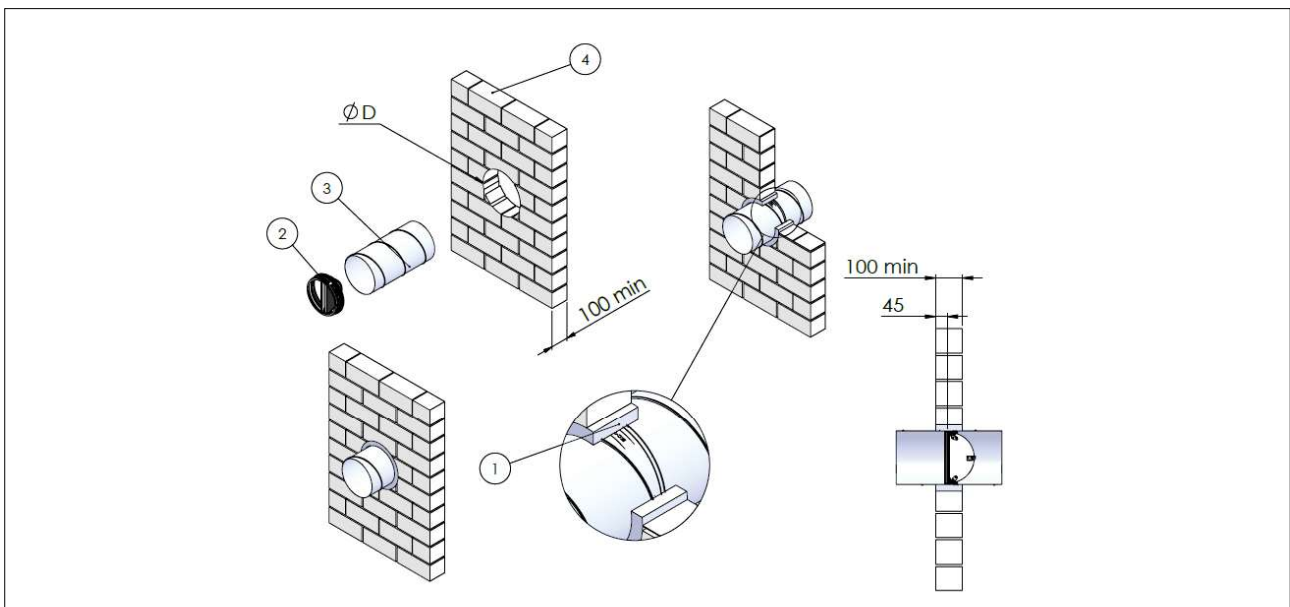



**Rigid wall, channelled one side, circular hole, mortar or plaster putty**

- |                               |   |
|-------------------------------|---|
| 1. Mortar or plaster grouting | 4. Ventilation duct   |
| 2. Terminal valve             | 5. Vertical rigid wall  |
| 3. Fire damper                | D from nominal diameter min + 50 to nominal diameter max + 70 |

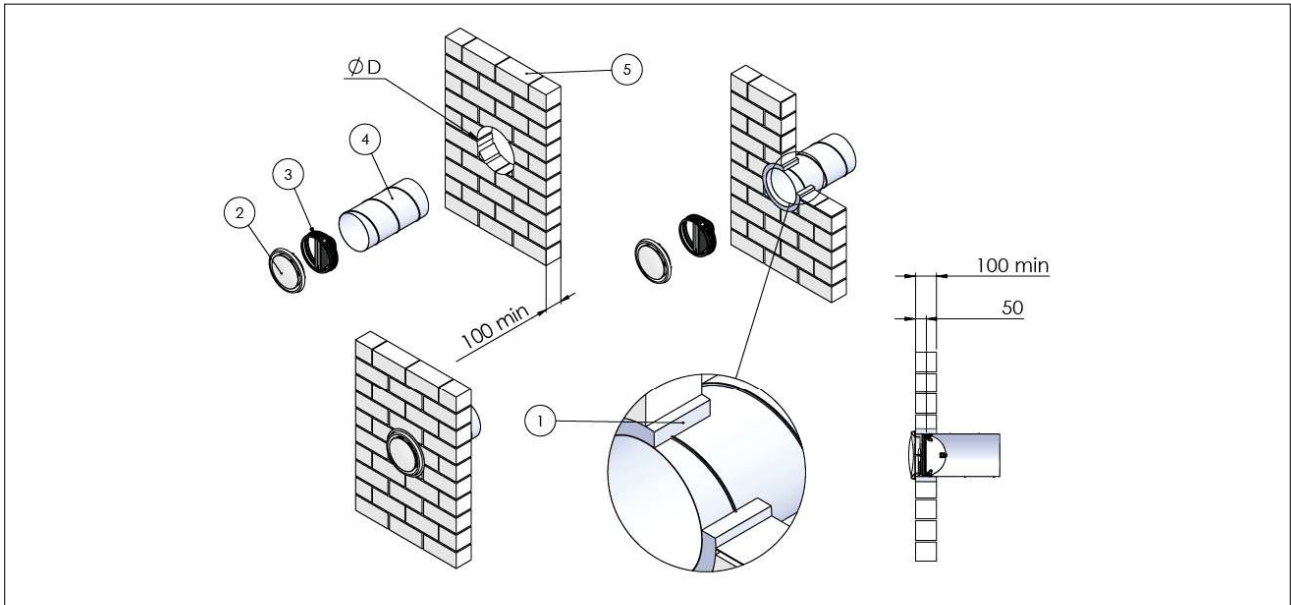

**Rigid wall, transfer, circular hole, mortar or plaster putty**

- |                               |   |
|-------------------------------|---|
| 1. Mortar or plaster grouting | 4. Ventilation duct   |
| 2. Terminal valve             | 5. Vertical rigid wall  |
| 3. Fire damper                | D from nominal diameter min + 50 to nominal diameter max + 70 |

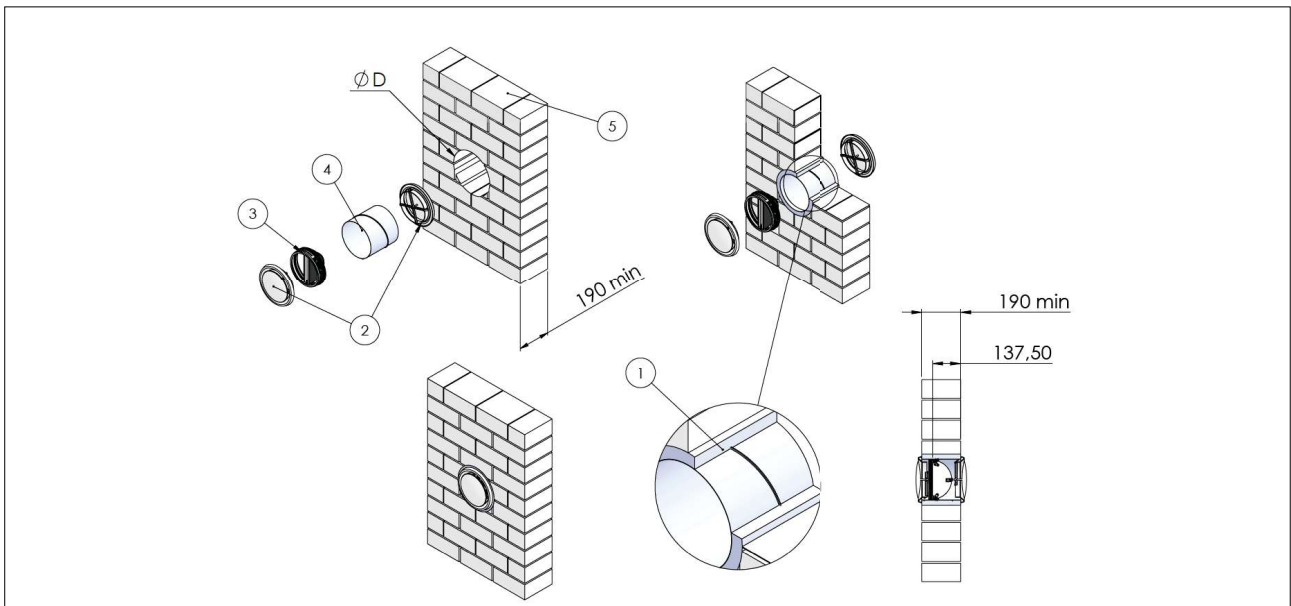

**Rigid wall, channelled both sides, circular hole, rock wool with mortar or plaster filler**

- |                                    |   |
|------------------------------------|---|
| 1. Rock wool, 40 kg/m <sup>3</sup> | 4. Ventilation duct   |
| 2. Mortar or plaster grouting      | 5. Vertical rigid wall  |
| 3. Fire damper                     | D from nominal diameter min + 50 to nominal diameter max + 70 |

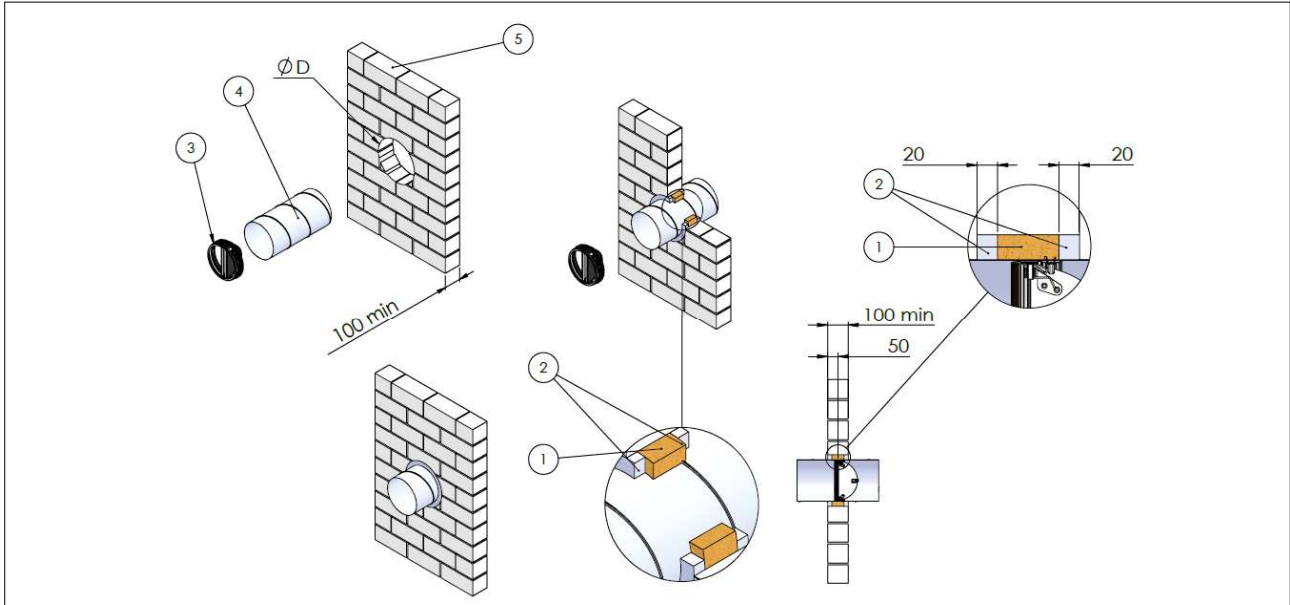

**Rigid wall, ducted one side, circular hole, rock wool with mortar or plaster putty**

- |                                    |   |
|------------------------------------|---|
| 1. Rock wool, 40 kg/m <sup>3</sup> | 5. Ventilation duct   |
| 2. Mortar or plaster grouting      | 6. Vertical rigid wall  |
| 3. Terminal valve                  | D from nominal diameter min + 50 to nominal diameter max + 70 |
| 4. Fire damper                     |   |

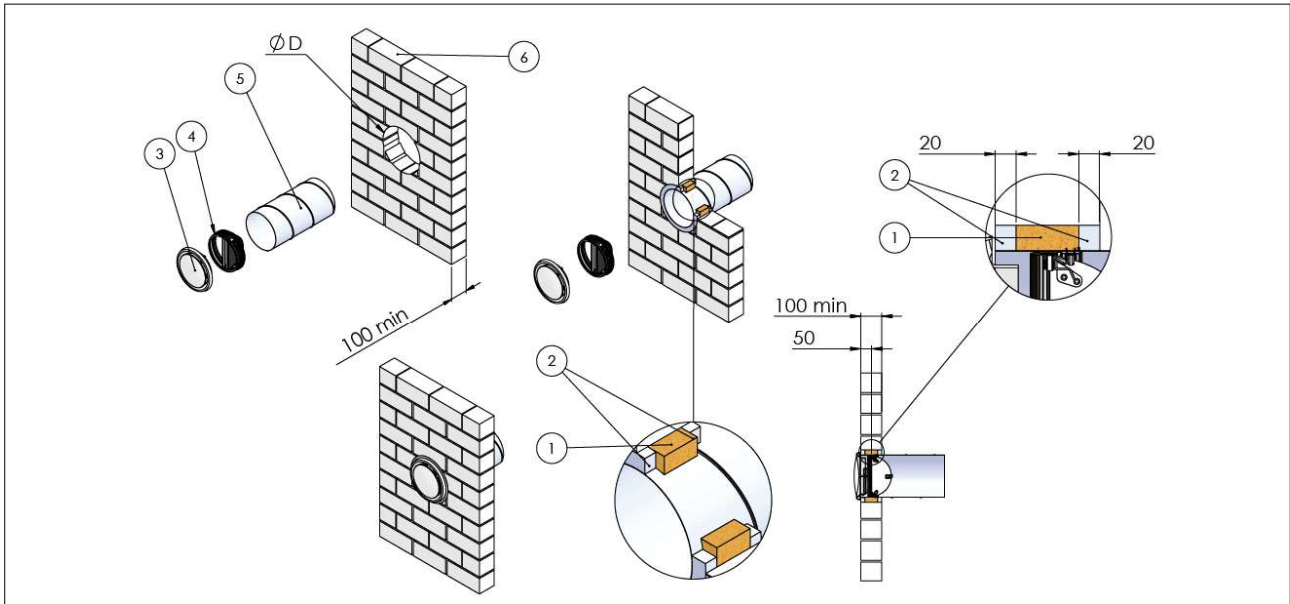

**Rigid wall, transfer, round hole, rock wool with mortar or plaster putty**

- |                                    |   |
|------------------------------------|---|
| 1. Mortar or plaster grouting      | 5. Ventilation duct   |
| 2. Rock wool, 40 kg/m <sup>3</sup> | 6. Vertical rigid wall  |
| 3. Terminal valve                  | D from nominal diameter min + 50 to nominal diameter max + 70 |
| 4. Fire damper                     |   |

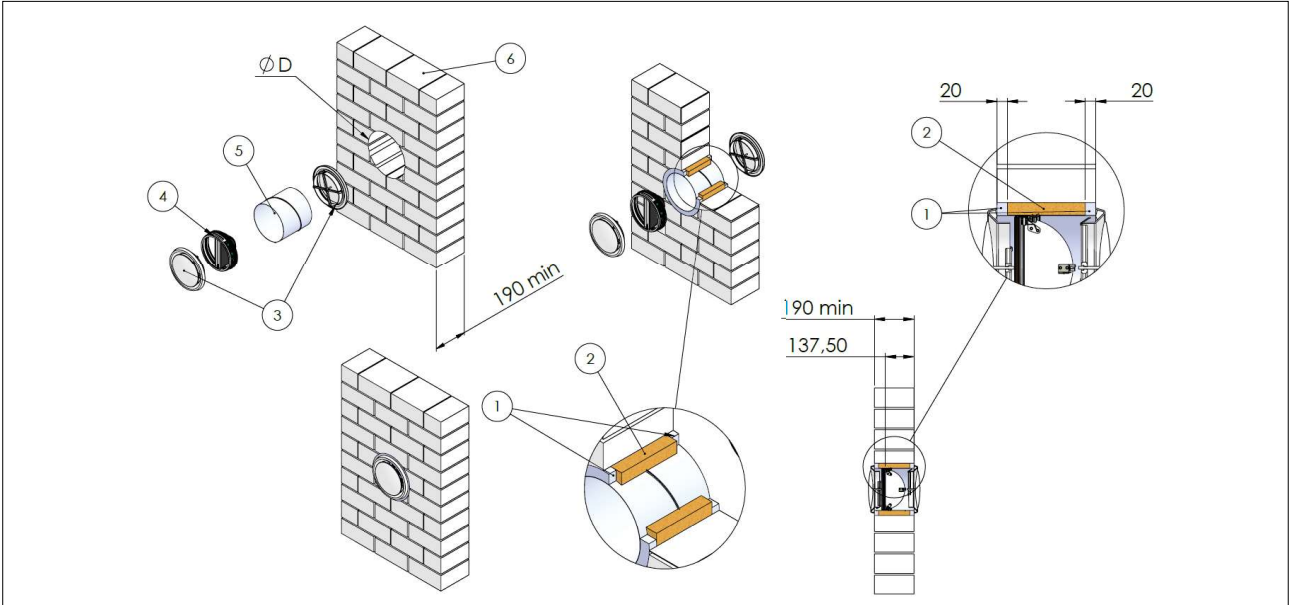

**Rigid wall, ducted both sides, circular hole, rock wool with plasterboard - EI60-S - FBC1**

- |                                    |   |
|------------------------------------|---|
| 1. Rock wool, 40 kg/m <sup>3</sup> | 5. Plasterboard arch infill type A, thickness 12,5 mm or promactect 100 thickness 12 mm |
| 2. Fire damper                     | 6. Self-drilling screw Ø 3,5 X 45 mm  |
| 3. Ventilation duct                | D from nominal diameter min + 50 to nominal diameter max + 70                           |
| 4. Rigid vertical wall             |   |

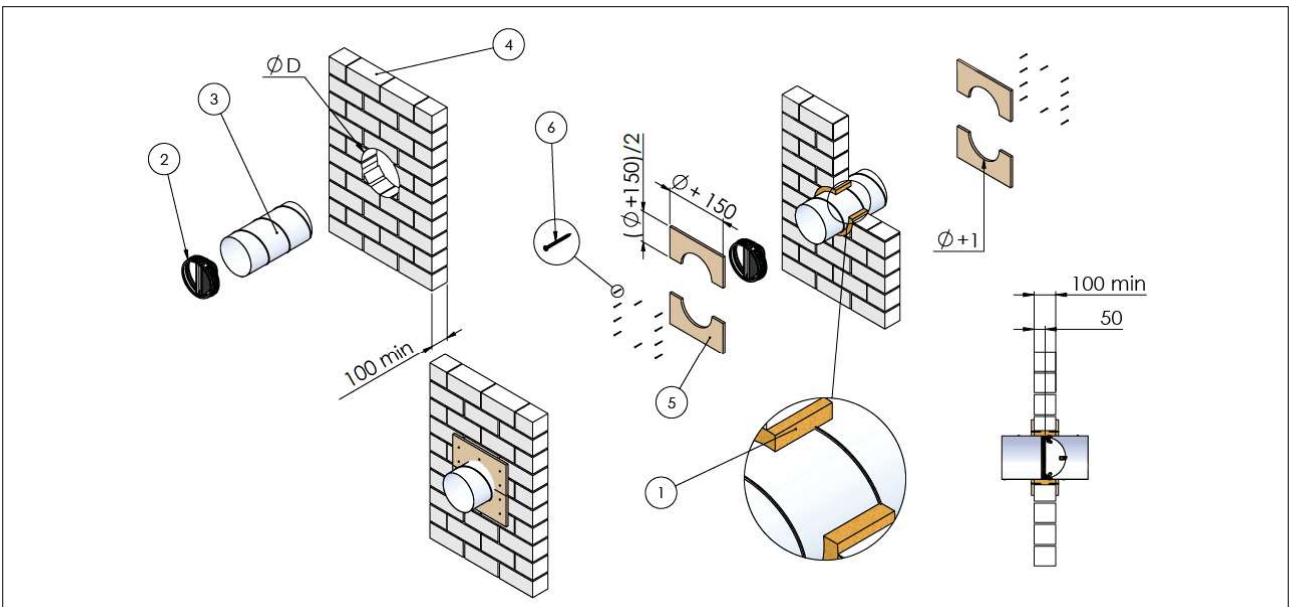

**Rigid wall, ducted both sides, circular hole, rock wool with plasterboard - EI90-S - FBC4- EI120-S - FBC7**

- |                                    |   |
|------------------------------------|---|
| 1. Rock wool, 40 kg/m <sup>3</sup> | 5. Plasterboards arch infill type F, thickness 12,5 mm or promatect 100 thickness 12 mm |
| 2. Fire damper                     | 6. Self-drilling screw Ø 3,5 X 45 mm  |
| 3. Ventilation duct                | D from nominal diameter min + 50 to nominal diameter max + 70                           |
| 4. Rigid vertical wall             |   |

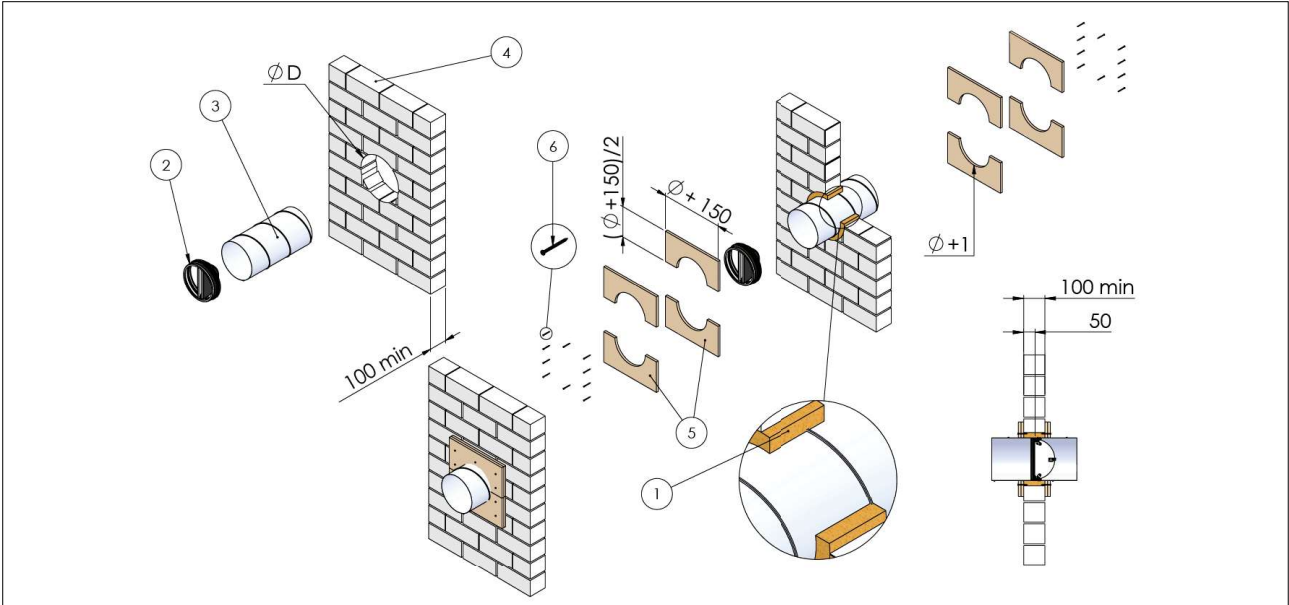

**Rigid wall, ducted one side, circular hole, rock wool with plasterboard**

- |                                    |   |
|------------------------------------|---|
| 1. Rock wool, 40 kg/m <sup>3</sup> | 6. Plasterboard arch infill, thickness 12,5 mm or promatect 100 thickness 12 mm |
| 2. Terminal valve                  | 7. Self-drilling screw Ø 3,5 X 45 mm  |
| 3. Fire damper                     | D from nominal diameter min + 50 to nominal diameter max + 70                   |
| 4. Ventilation duct                |   |
| 5. Rigid vertical wall             |   |

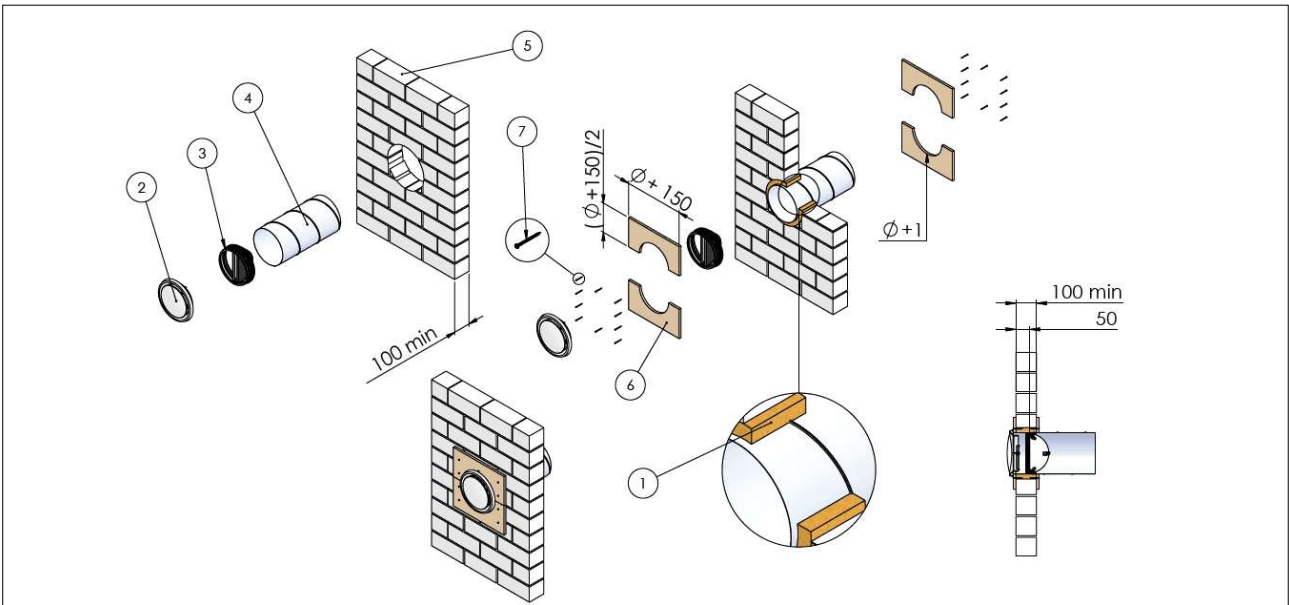

**Rigid wall, transfer, round hole, rock wool with plasterboard**

- |   |  |
|---|--|
| <ol style="list-style-type: none"> <li>1. Rock wool, 40 kg/m<sup>3</sup></li> <li>2. Terminal valve</li> <li>3. Fire damper</li> <li>4. Ventilation duct</li> <li>5. Rigid vertical wall</li> </ol> | <ol style="list-style-type: none"> <li>6. Plasterboard arch infill, thickness 12,5 mm or promatect 100 thickness 12 mm</li> <li>7. Self-drilling screw Ø 3,5 X 45 mm</li> </ol> <p>D from nominal diameter min + 50 to nominal diameter max + 70</p> |
|---|--|

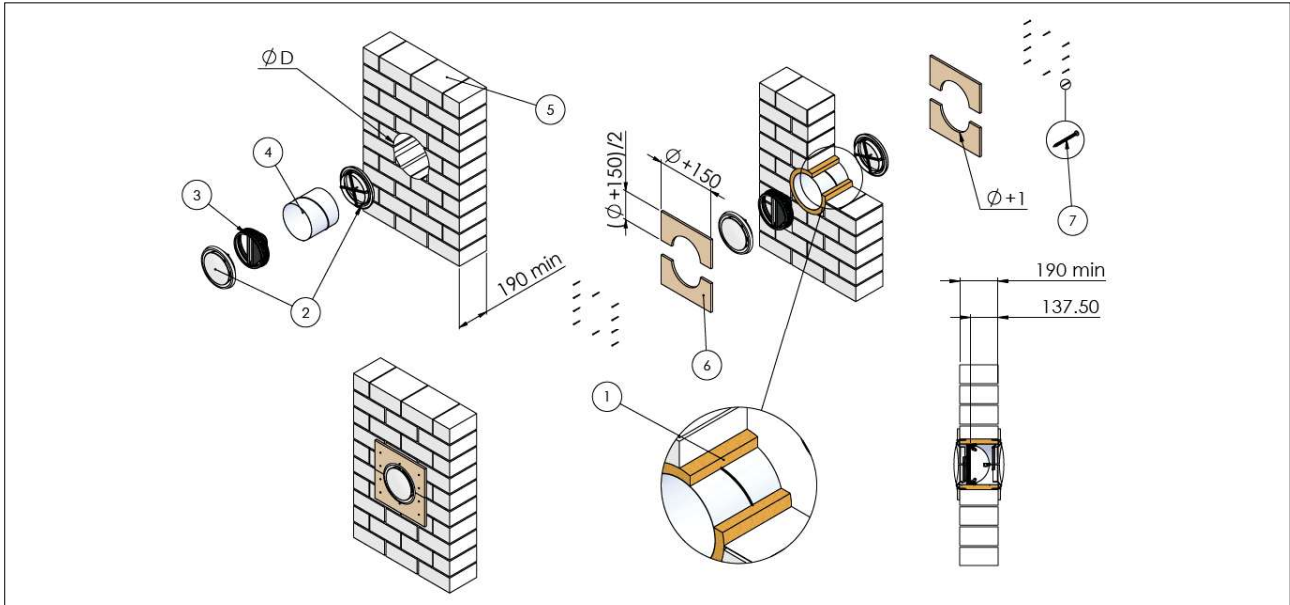

### 3.8. Installations within vertical light wall (plasterboard)

See section Construction supports characteristics for more details, observe the minimum distances indicated in section Minimum distances, carry out a functional test before and after installation. See section for more details.

#### 3.8.1. Wall opening

A opening must be provided in the wall as indicated in the drawing.

#### 3.8.2. Damper positioning

Install the fire damper in the ventilation duct as shown in the drawing. Close the blade before installing the fire damper

#### 3.8.3. Filling

Fill the space between ventilation duct and wall as indicated in the drawing.

#### 3.8.4. Insulation

Only in the case of light vertical walls, with two dampers closer than 200 mm and rock wool sealing, BELT-FBC-Ø bands (see section Accessories and spare parts) are required, which are applied to the duct on both sides of the wall or cavity on the accessible side only. With grout or mortar sealing, the strips are NEVER necessary.

The shafts shall have fire resistance equal or higher to the one of the fire damper.

#### Light wall, ducted on both sides, square hole, mortar or plaster putty

- |    |  |    |   |
|----|--|----|---|
| 1. | Rock wool density up to 40 kg/m <sup>3</sup> (optional)                      | 4. | Mortar or plaster putty                                     |
| 2. | Metal frame  | 5. | Fire damper   |
| 3. | plasterboard, thickness 12,5 mm type A: FBC1; type F: FBC4 and FBC7 (EN 520) | 6. | Ventilation duct  |
|    |  | D  | from nominal diameter min + 50 to nominal diameter max + 70 |

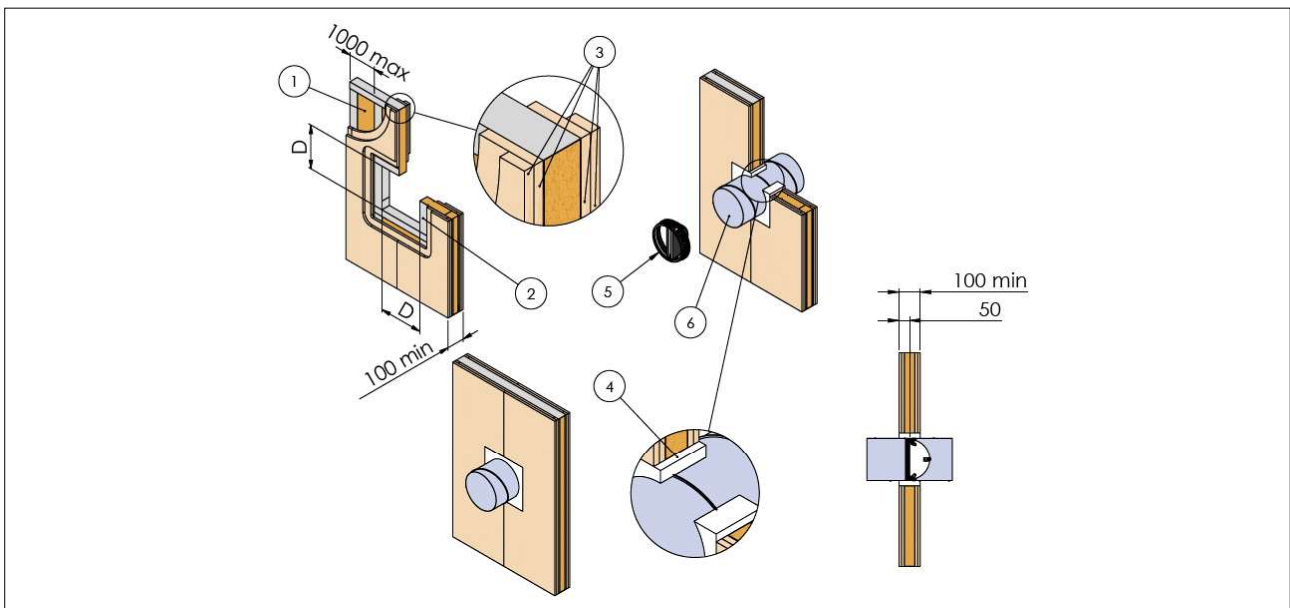



**Light wall, ducted on one side, square hole, mortar or plaster putty**

- |   |   |
|---|---|
| 1. Rock wool density up to 40 kg/m <sup>3</sup> (optional)                      | 5. Terminal valve   |
| 2. Metal frame  | 6. Fire damper  |
| 3. plasterboard, thickness 12,5 mm type A: FBC1; type F: FBC4 and FBC7 (EN 520) | 7. Ventilation duct   |
| 4. Mortar or plaster putty  | D from nominal diameter min + 50 to nominal diameter max + 70 |

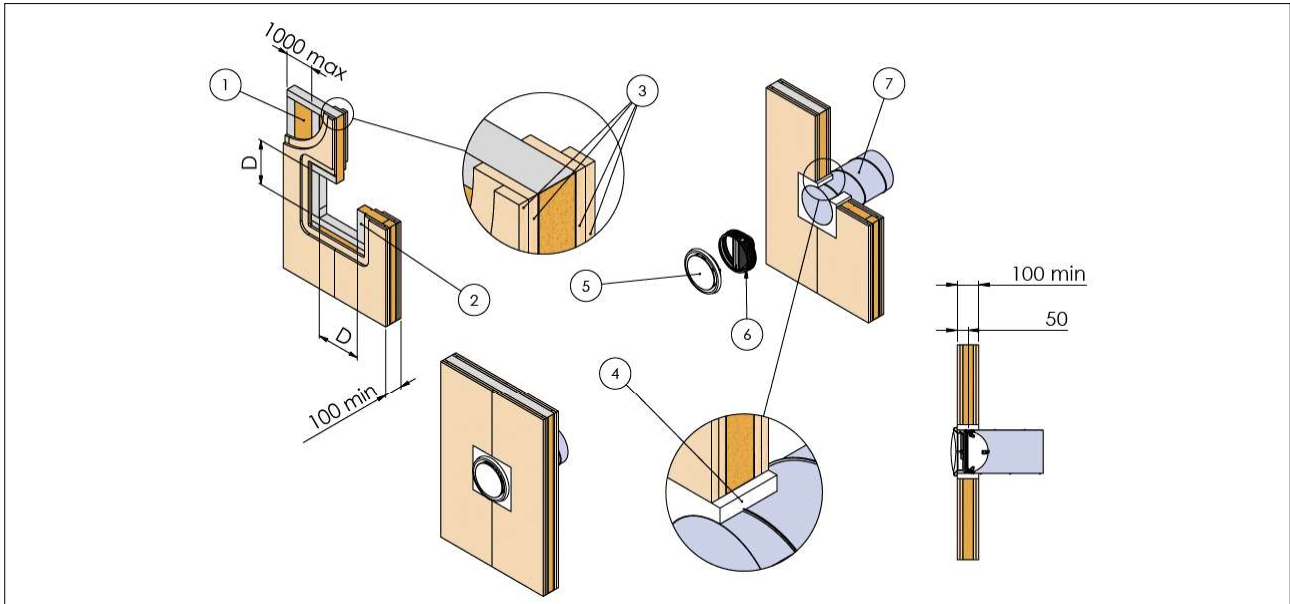

**Light wall, transfer, square hole, rock wool with mortar or plaster putty**

- |   |   |
|---|---|
| 1. Rock wool density up to 40 kg/m <sup>3</sup> (optional)                      | 5. Terminal valve   |
| 2. Metal frame  | 6. Fire damper  |
| 3. plasterboard, thickness 12,5 mm type A: FBC1; type F: FBC4 and FBC7 (EN 520) | 7. Ventilation duct   |
| 4. Mortar or plaster putty  | D from nominal diameter min + 50 to nominal diameter max + 70 |

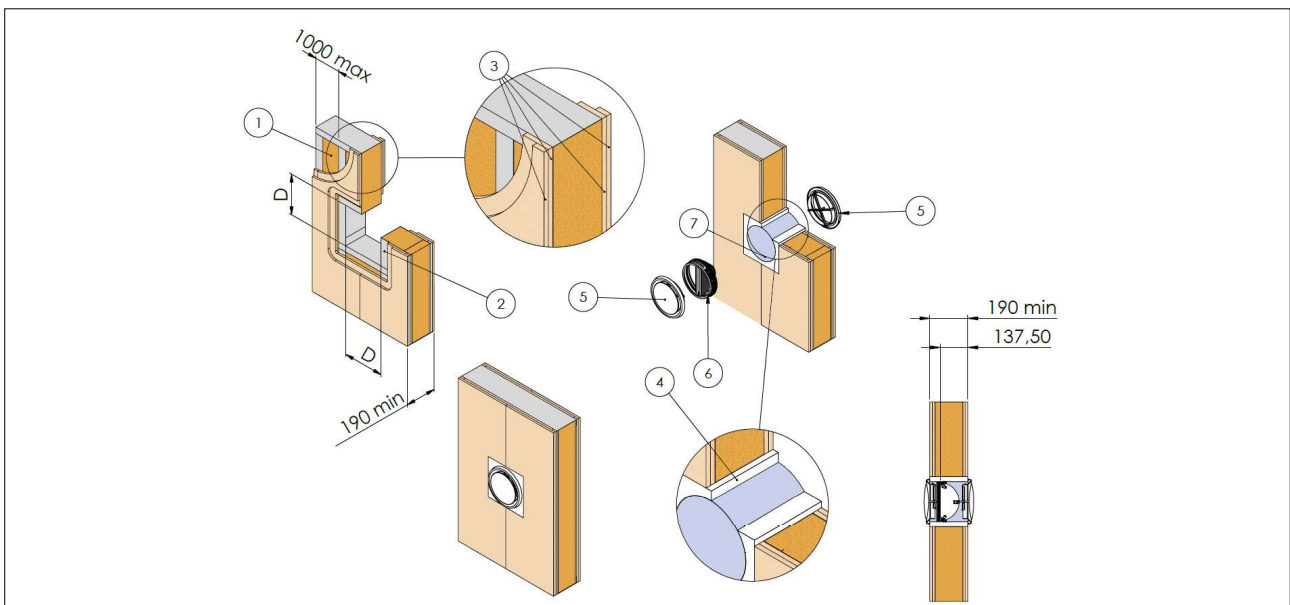

**Light wall, ducted on both sides, square hole, rock wool with mortar or plaster putty**

- |   |   |
|---|---|
| 1. Rock wool density up to 40 kg/m <sup>3</sup> (optional)                      | 5. Rock wool, 40 kg/m <sup>3</sup>                            |
| 2. Metal frame  | 6. Fire damper  |
| 3. plasterboard, thickness 12,5 mm type A: FBC1; type F: FBC4 and FBC7 (EN 520) | 7. Ventilation duct   |
| 4. Mortar or plaster putty  | D from nominal diameter min + 50 to nominal diameter max + 70 |

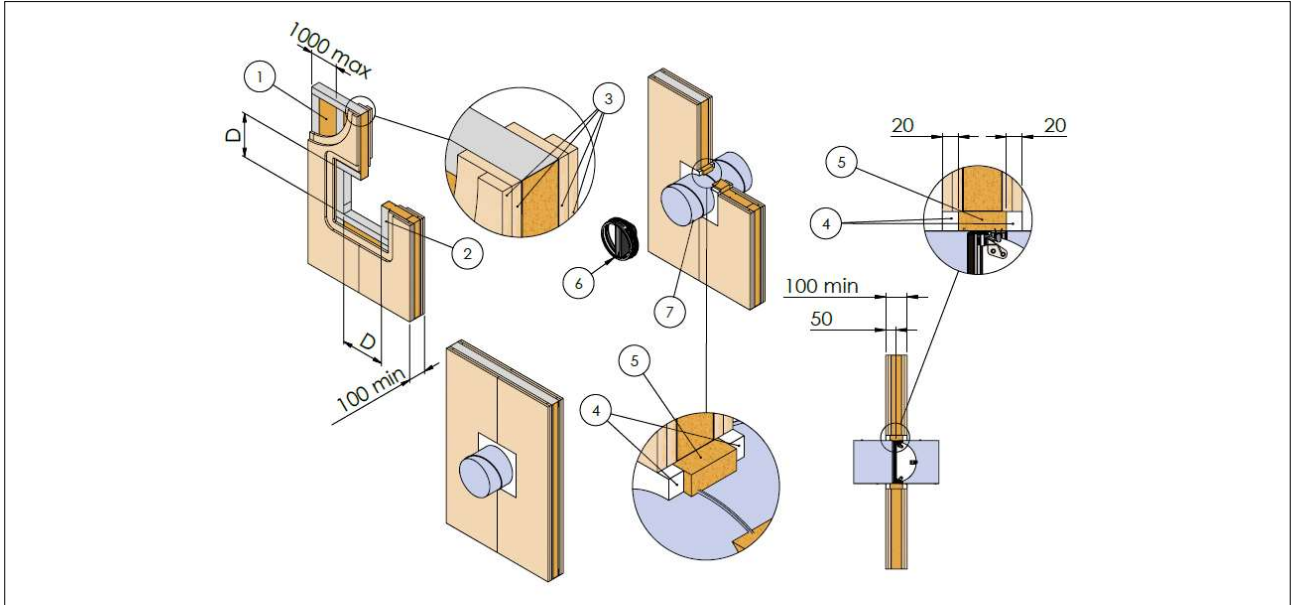

**Light wall, ducted on one side, square hole, rock wool with mortar or plaster putty**

- |   |   |
|---|---|
| 1. Rock wool density up to 40 kg/m <sup>3</sup> (optional)                      | 5. Rock wool, 40 kg/m <sup>3</sup>                            |
| 2. Metal frame  | 6. Terminal valve   |
| 3. plasterboard, thickness 12,5 mm type A: FBC1; type F: FBC4 and FBC7 (EN 520) | 7. Fire damper  |
| 4. Mortar or plaster putty  | 8. Ventilation duct   |
|   | D from nominal diameter min + 50 to nominal diameter max + 70 |

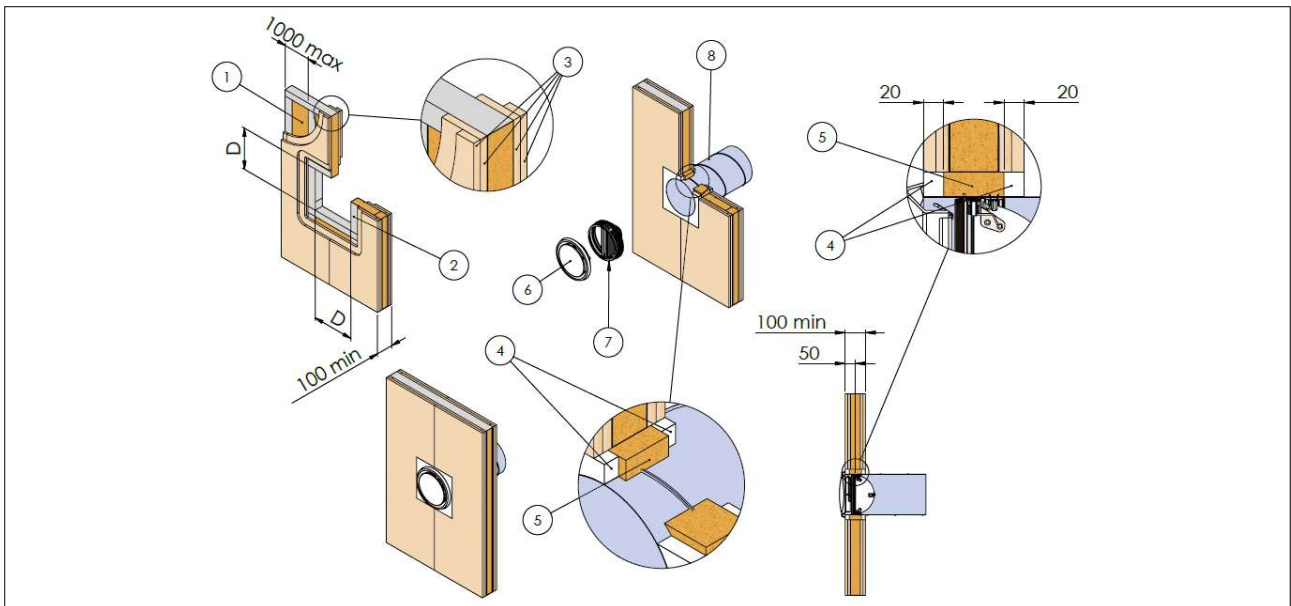



**Light wall, transfer, square hole, rock wool with mortar or plaster putty**

- |   |   |
|---|---|
| 1. Rock wool density up to 40 kg/m <sup>3</sup> (optional)                      | 5. Mortar or plaster putty                                    |
| 2. Metal frame  | 6. Terminal valve   |
| 3. plasterboard, thickness 12,5 mm type A: FBC1; type F: FBC4 and FBC7 (EN 520) | 7. Fire damper  |
| 4. Rock wool, 40 kg/m <sup>3</sup>  | 8. Ventilation duct   |
|   | D from nominal diameter min + 50 to nominal diameter max + 70 |

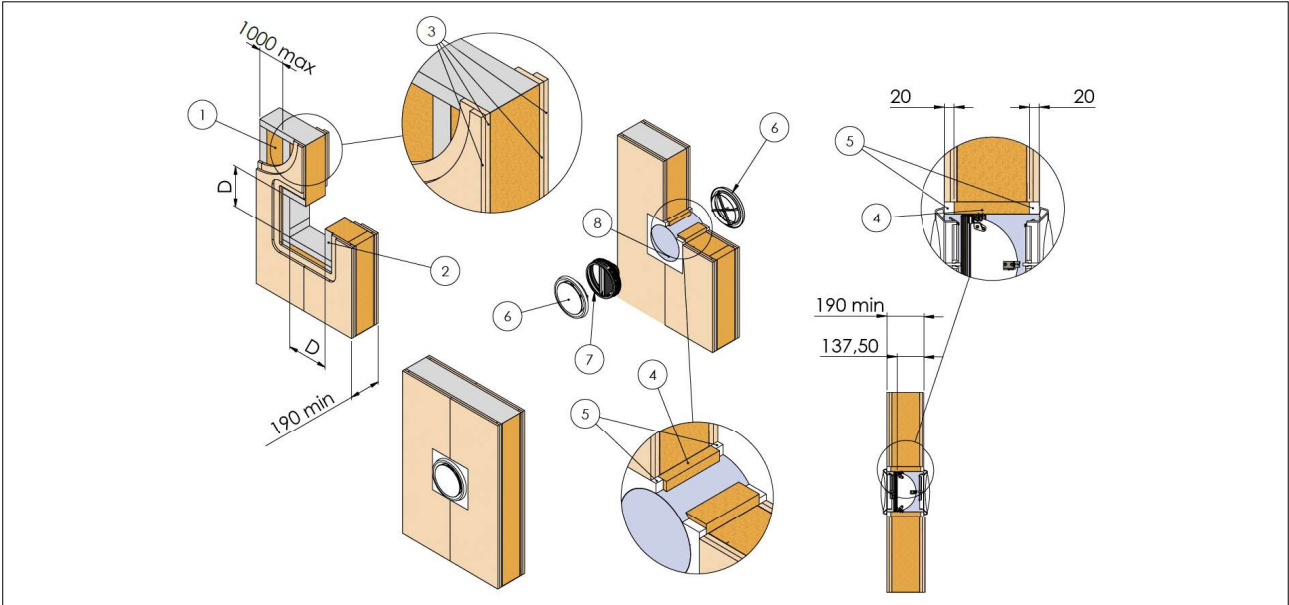

**Light wall, ducted both sides, square hole, rock wool with plasterboard - EI60-S - FBC1**

- |   |  |
|---|--|
| 1. Rock wool density up to 40 kg/m <sup>3</sup> (optional)                      | 6. Ventilation duct  |
| 2. Metal frame  | 7. Self-drilling screw $\varnothing$ 3,5 X 45 mm                                       |
| 3. plasterboard, thickness 12,5 mm type A: FBC1; type F: FBC4 and FBC7 (EN 520) | 8. Plasterboard arch infill type A, thickness 12,5 mm or promatect 100 thickness 12 mm |
| 4. Rock wool, 40 kg/m <sup>3</sup>  | D from nominal diameter min + 50 to nominal diameter max + 70                          |
| 5. Fire damper  |  |

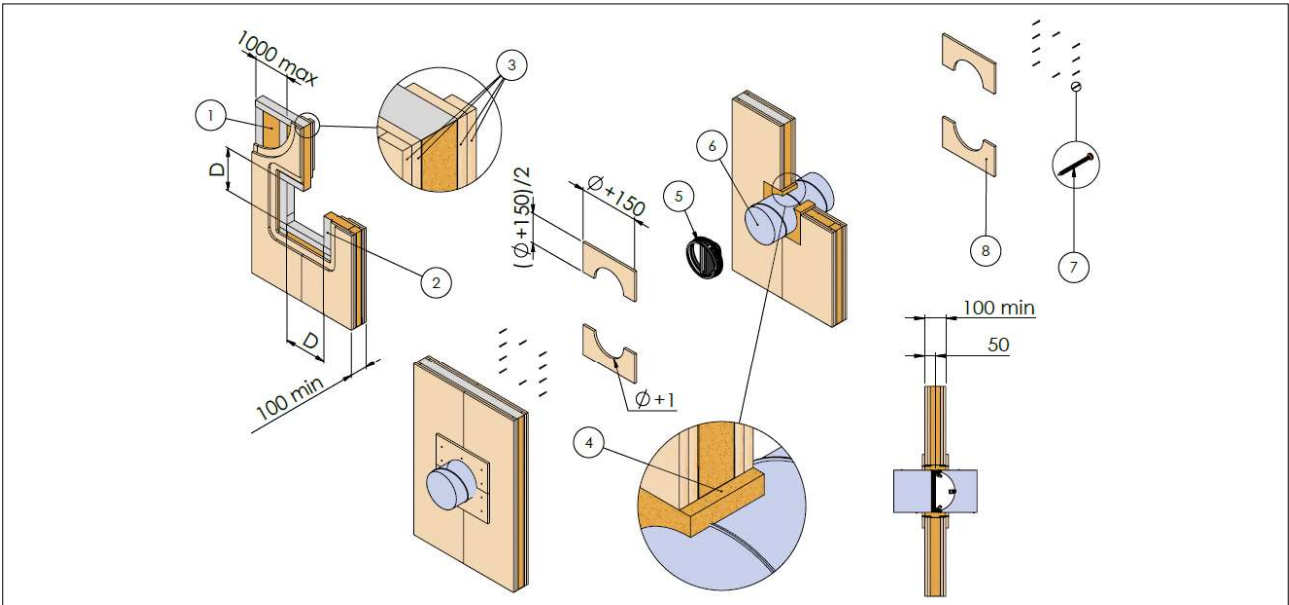

**Light wall, ducted both sides, square hole, rock wool with plasterboard - EI90-S - FBC4- EI120-S - FBC7**

- |   |   |
|---|---|
| 1. Rock wool density up to 40 kg/m <sup>3</sup> (optional)                      | 6. Ventilation duct   |
| 2. Metal frame  | 7. Self-drilling screw Ø 3,5 X 45 mm  |
| 3. plasterboard, thickness 12,5 mm type A: FBC1; type F: FBC4 and FBC7 (EN 520) | 8. Plasterboards arch infill type F, thickness 12,5 mm or promatect 100 thickness 12 mm |
| 4. Rock wool, 40 kg/m <sup>3</sup>  | D from nominal diameter min + 50 to nominal diameter max + 70                           |
| 5. Fire damper  |   |

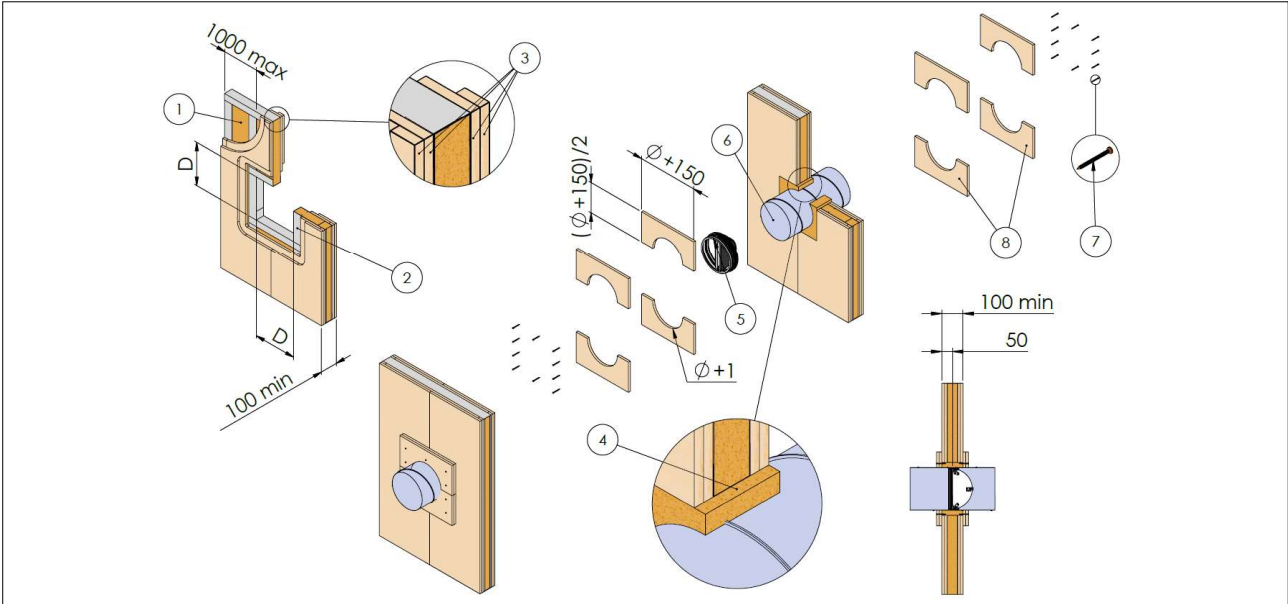

**Light wall, ducted one side, square hole, rock wool with plasterboard**

- |   |  |
|---|--|
| 1. Rock wool density up to 40 kg/m <sup>3</sup> (optional)                      | 6. Fire damper   |
| 2. Metal frame  | 7. Ventilation duct  |
| 3. plasterboard, thickness 12,5 mm type A: FBC1; type F: FBC4 and FBC7 (EN 520) | 8. Plasterboards arch infill, thickness 12,5 mm or promatect 100 thickness 12 mm |
| 4. Rock wool, 40 kg/m <sup>3</sup>  | 9. Self-drilling screw Ø 3,5 X 45 mm   |
| 5. Terminal valve   | D from nominal diameter min + 50 to nominal diameter max + 70                    |

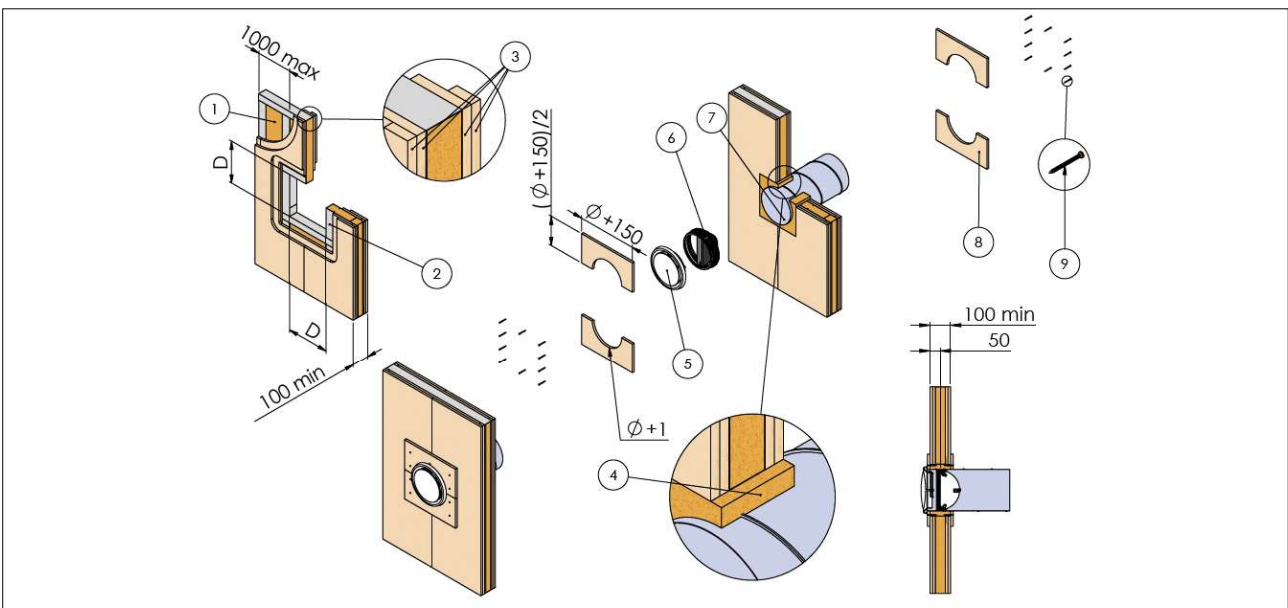

**Light wall, transfer, square hole, rock wool with plasterboard**

- |   |   |
|---|---|
| 1. Rock wool density up to 40 kg/m <sup>3</sup> (optional)                      | 6. Fire damper  |
| 2. Metal frame  | 7. Ventilation duct   |
| 3. plasterboard, thickness 12,5 mm type A: FBC1; type F: FBC4 and FBC7 (EN 520) | 8. Plasterboard arch infill, thickness 12,5 mm or promatect 100 thickness 12 mm |
| 4. Rock wool, 40 kg/m <sup>3</sup>  | 9. Self-drilling screw $\varnothing$ 3,5 X 45 mm                                |
| 5. Terminal valve   | D from nominal diameter min + 50 to nominal diameter max + 70                   |

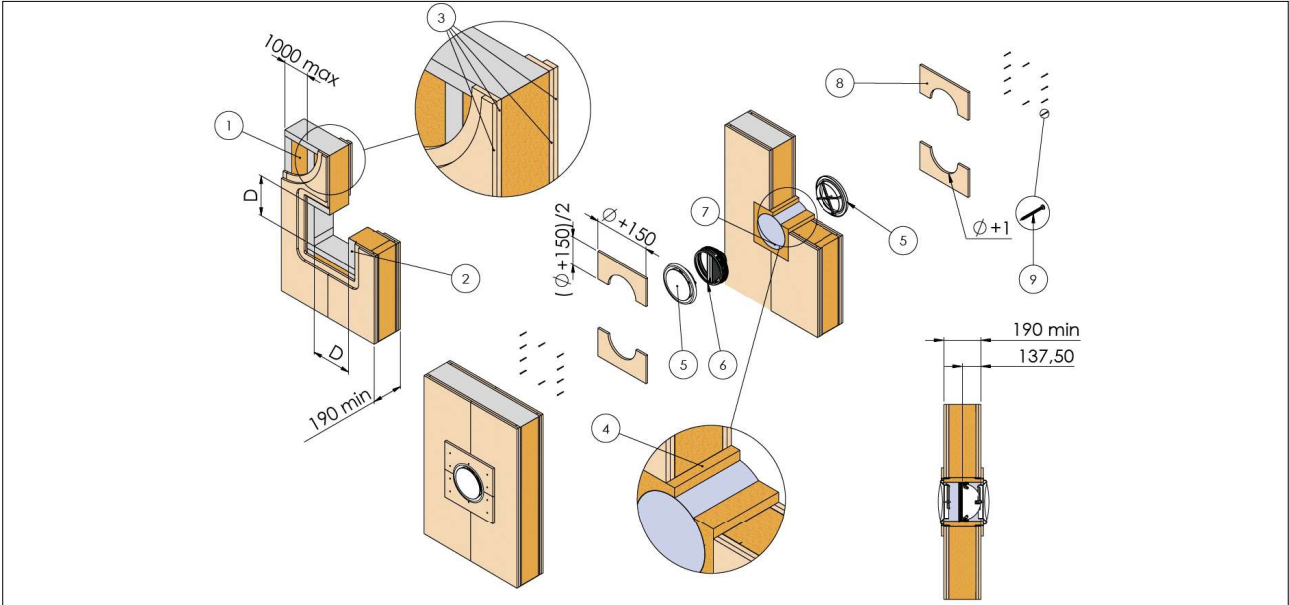

**Light wall, ducted both sides, circular hole, mortar or plaster filler**

- |   |   |
|---|---|
| 1. Rock wool density up to 40 kg/m <sup>3</sup> (optional)                      | 4. Mortar or plaster putty                                    |
| 2. Metal frame  | 5. Fire damper  |
| 3. plasterboard, thickness 12,5 mm type A: FBC1; type F: FBC4 and FBC7 (EN 520) | 6. Ventilation duct   |
|   | D from nominal diameter min + 50 to nominal diameter max + 70 |

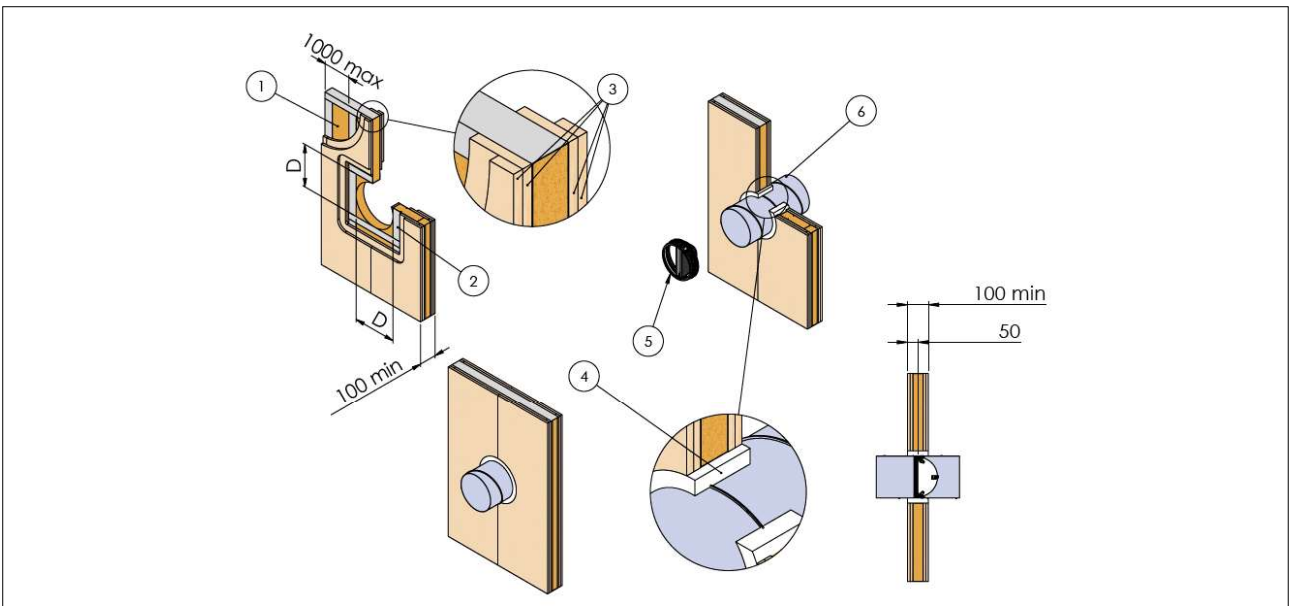

**Light wall, ducted one side, circular hole, mortar or plaster putty**

- |   |   |
|---|---|
| 1. Rock wool density up to 40 kg/m <sup>3</sup> (optional)                      | 5. Terminal valve   |
| 2. Metal frame  | 6. Fire damper  |
| 3. plasterboard, thickness 12,5 mm type A: FBC1; type F: FBC4 and FBC7 (EN 520) | 7. Ventilation duct   |
| 4. Mortar or plaster putty  | D from nominal diameter min + 50 to nominal diameter max + 70 |

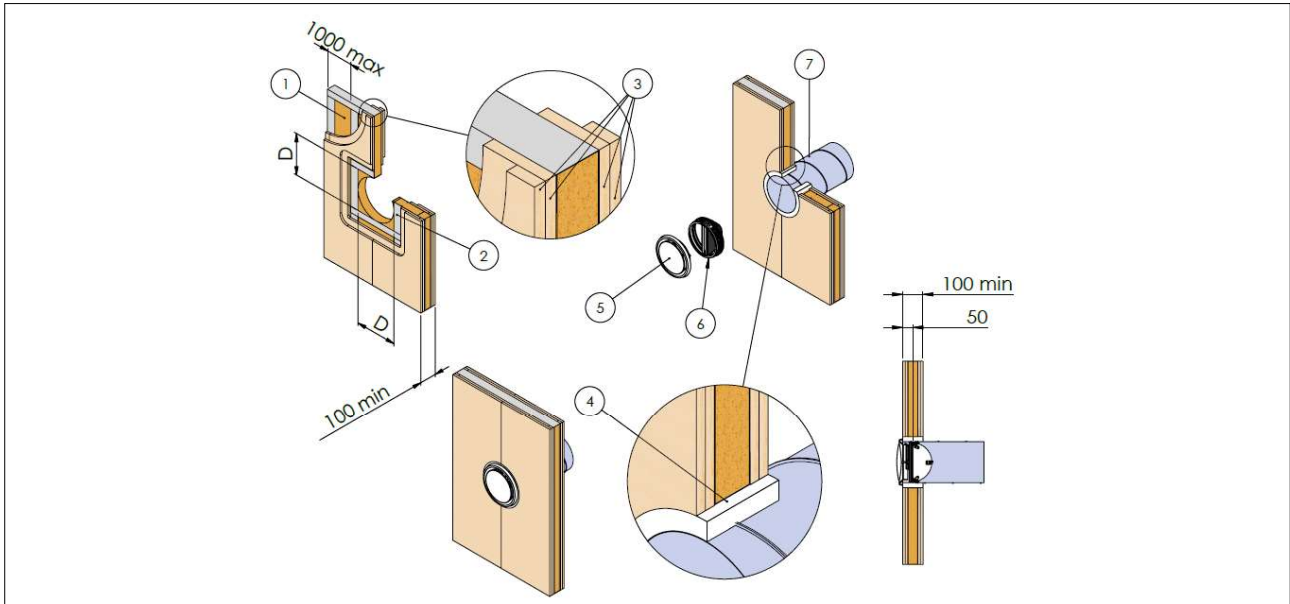

**Light wall, transfer, circular hole, mortar or plaster putty**

- |   |   |
|---|---|
| 1. Rock wool density up to 40 kg/m <sup>3</sup> (optional)                      | 5. Terminal valve   |
| 2. Metal frame  | 6. Fire damper  |
| 3. plasterboard, thickness 12,5 mm type A: FBC1; type F: FBC4 and FBC7 (EN 520) | 7. Ventilation duct   |
| 4. Mortar or plaster putty  | D from nominal diameter min + 50 to nominal diameter max + 70 |

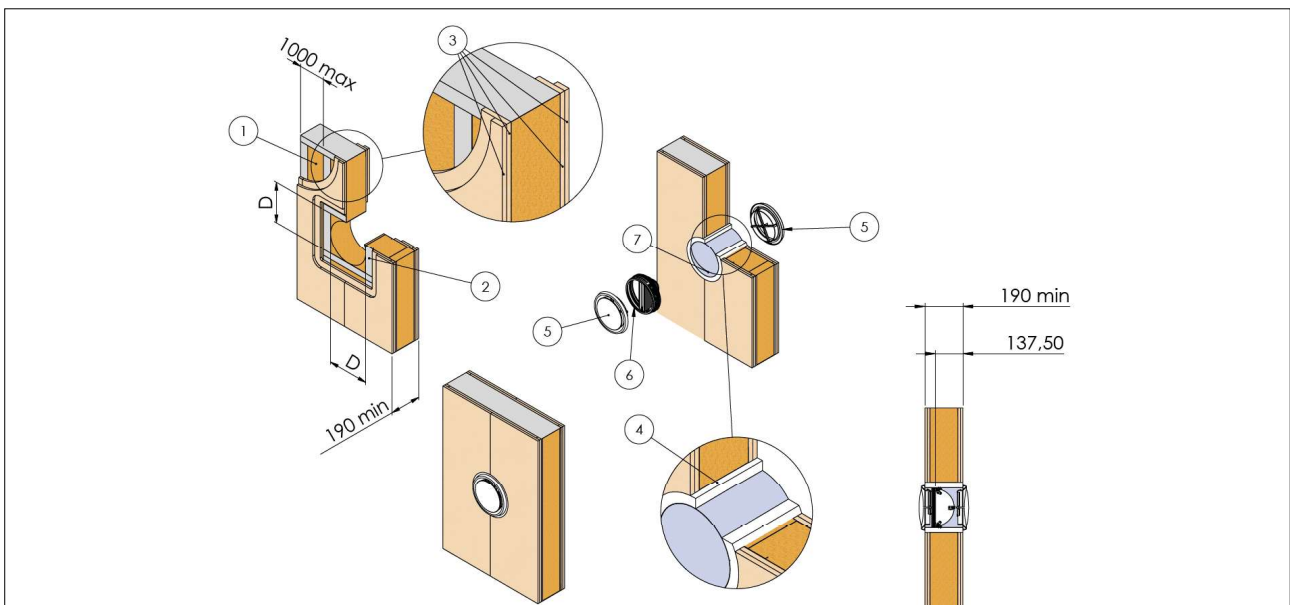

**Light wall, ducted both sides, circular hole, rock wool with mortar or plaster filler**

- |   |   |
|---|---|
| 1. Rock wool density up to 40 kg/m <sup>3</sup> (optional)                      | 5. Mortar or plaster putty                                    |
| 2. Metal frame  | 6. Fire damper  |
| 3. plasterboard, thickness 12,5 mm type A: FBC1; type F: FBC4 and FBC7 (EN 520) | 7. Ventilation duct   |
| 4. Rock wool, 40 kg/m <sup>3</sup>  | D from nominal diameter min + 50 to nominal diameter max + 70 |

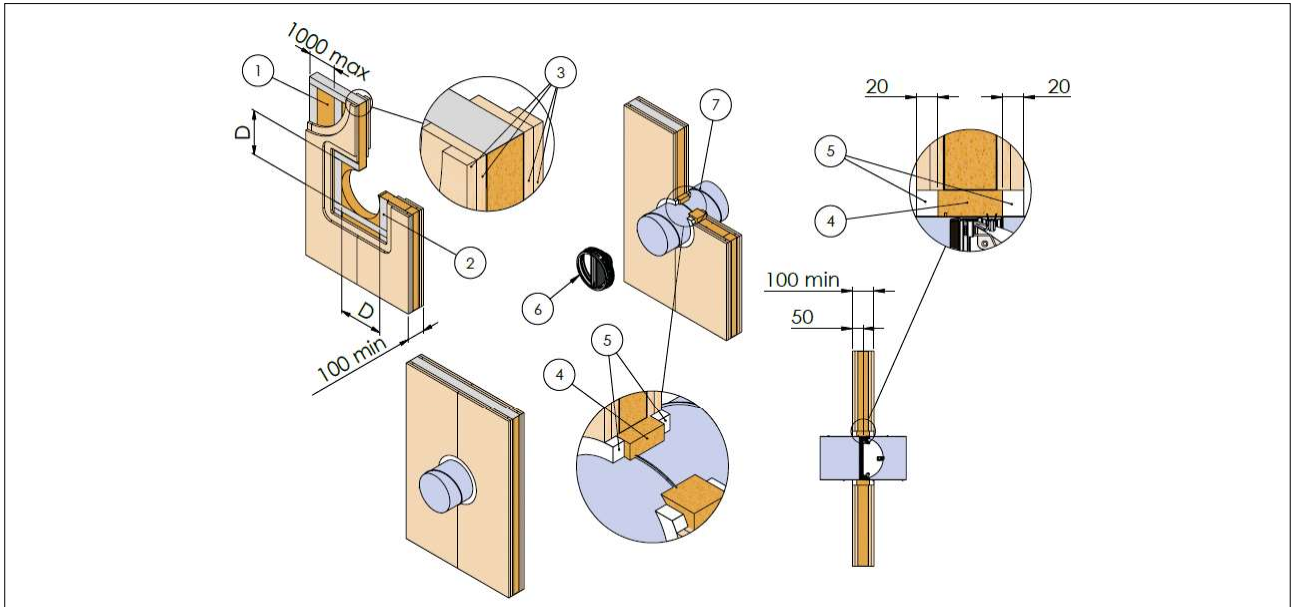

**Light wall, ducted one side, circular hole, rock wool with mortar or plaster putty**

- |   |   |
|---|---|
| 1. Rock wool density up to 40 kg/m <sup>3</sup> (optional)                      | 5. Rock wool, 40 kg/m <sup>3</sup>                            |
| 2. Metal frame  | 6. Terminal valve   |
| 3. plasterboard, thickness 12,5 mm type A: FBC1; type F: FBC4 and FBC7 (EN 520) | 7. Fire damper  |
| 4. Mortar or plaster putty  | 8. Ventilation duct   |
|   | D from nominal diameter min + 50 to nominal diameter max + 70 |

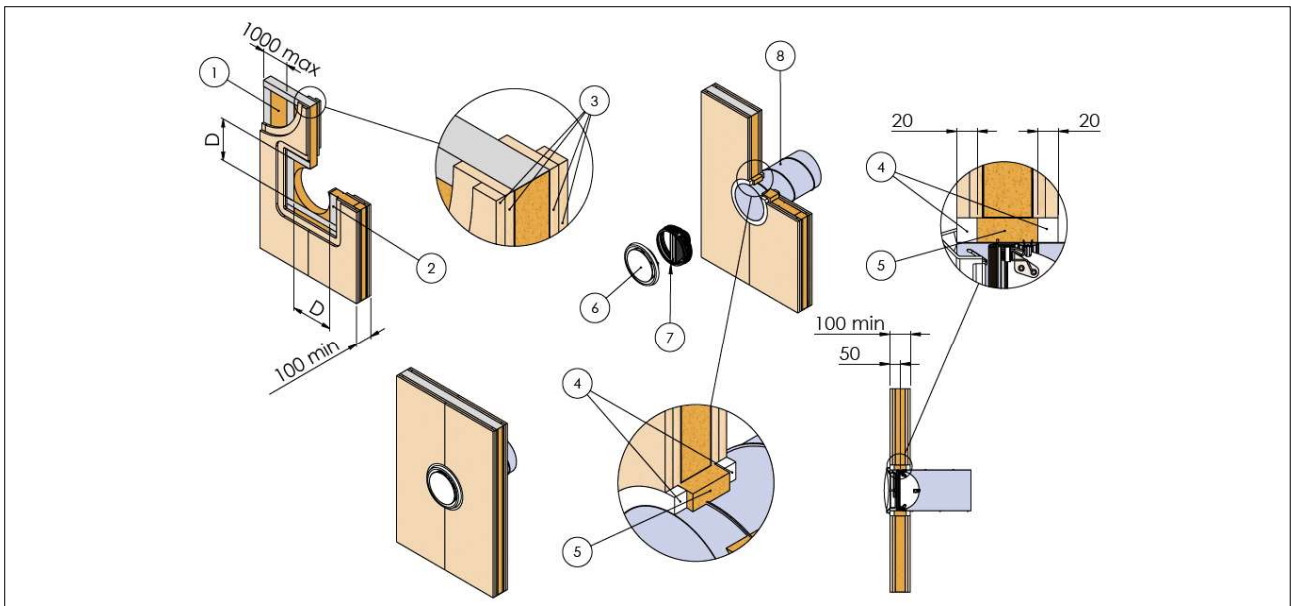



**Light wall, transfer, round hole, rock wool with mortar or plaster putty**

- |   |   |
|---|---|
| 1. Rock wool density up to 40 kg/m <sup>3</sup> (optional)                      | 5. Mortar or plaster putty                                    |
| 2. Metal frame  | 6. Terminal valve   |
| 3. plasterboard, thickness 12,5 mm type A: FBC1; type F: FBC4 and FBC7 (EN 520) | 7. Fire damper  |
| 4. Rock wool, 40 kg/m <sup>3</sup>  | 8. Ventilation duct   |
|   | D from nominal diameter min + 50 to nominal diameter max + 70 |

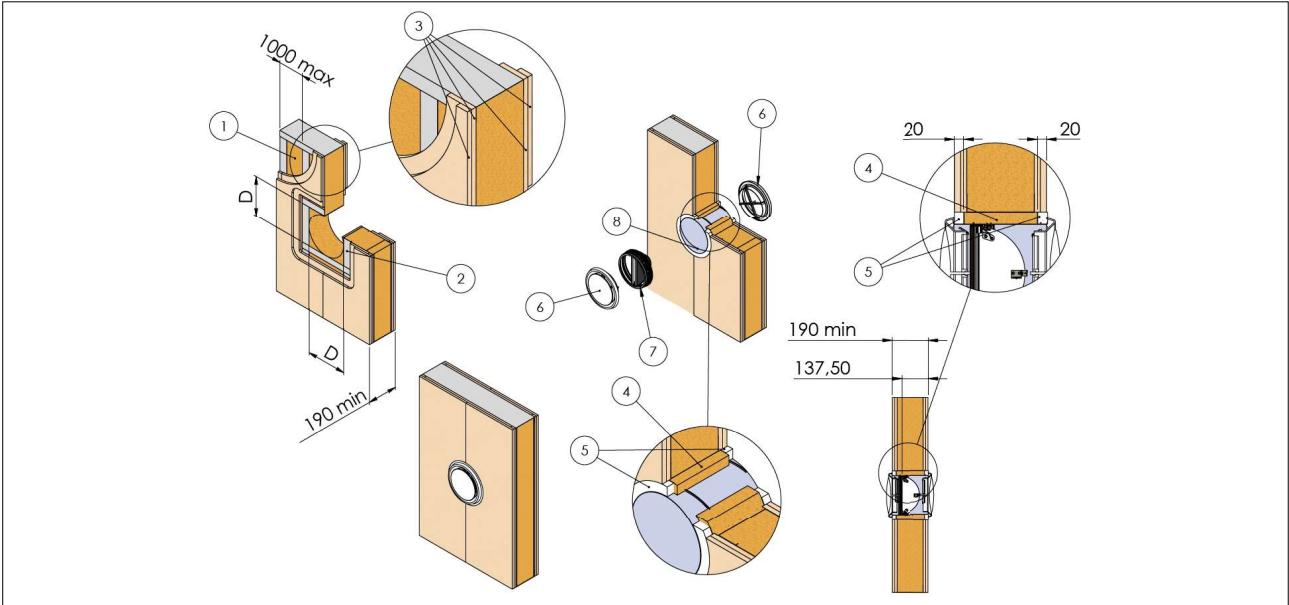

**Light wall, ducted both sides, circular hole, rock wool with plasterboard - EI60-S - FBC1**

- |   |  |
|---|--|
| 1. Rock wool density up to 40 kg/m <sup>3</sup> (optional)                      | 6. Ventilation duct  |
| 2. Metal frame  | 7. Plasterboard arch infill type A, thickness 12,5 mm or promactec 100 thickness 12 mm |
| 3. plasterboard, thickness 12,5 mm type A: FBC1; type F: FBC4 and FBC7 (EN 520) | 8. Self-drilling screw $\varnothing 3,5 \times 45$ mm                                  |
| 4. Rock wool, 40 kg/m <sup>3</sup>  | D from nominal diameter min + 50 to nominal diameter max + 70                          |
| 5. Fire damper  |  |

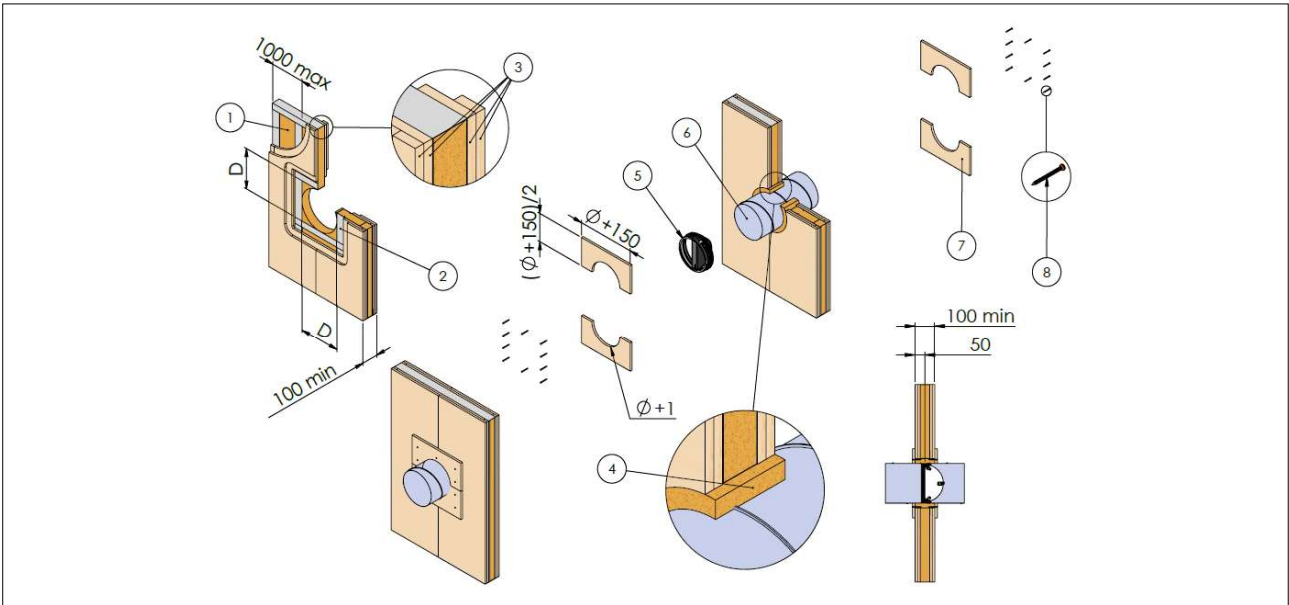

**Light wall, ducted both sides, circular hole, rock wool with plasterboard - EI90-S - FBC4- EI120-S - FBC7**

- |   |   |
|---|---|
| 1. Rock wool density up to 40 kg/m <sup>3</sup> (optional)                      | 6. Ventilation duct   |
| 2. Metal frame  | 7. Plasterboards arch infill type F, thickness 12,5 mm or promatect 100 thickness 12 mm |
| 3. plasterboard, thickness 12,5 mm type A: FBC1; type F: FBC4 and FBC7 (EN 520) | 8. Self-drilling screw $\varnothing$ 3,5 X 45 mm  |
| 4. Rock wool, 40 kg/m <sup>3</sup>  | D from nominal diameter min + 50 to nominal diameter max + 70                           |
| 5. Fire damper  |   |

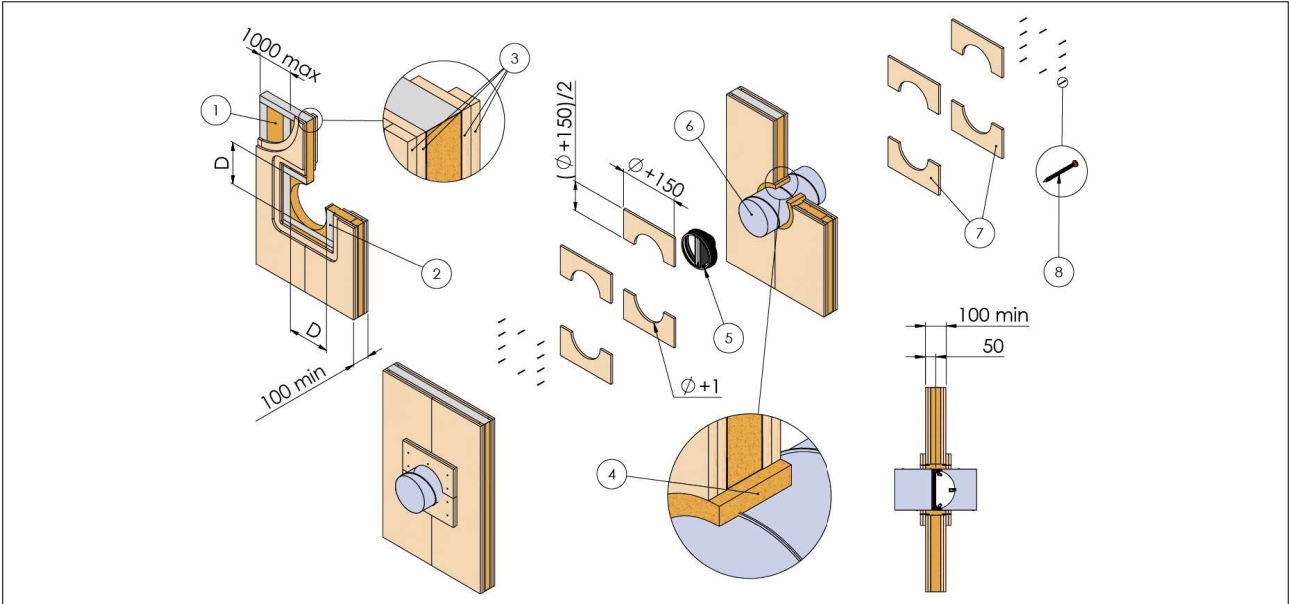

**Light wall, ducted one side, circular hole, rock wool with plasterboard**

- |   |   |
|---|---|
| 1. Rock wool density up to 40 kg/m <sup>3</sup> (optional)                      | 6. Fire damper  |
| 2. Metal frame  | 7. Ventilation duct   |
| 3. plasterboard, thickness 12,5 mm type A: FBC1; type F: FBC4 and FBC7 (EN 520) | 8. Plasterboard arch infill, thickness 12,5 mm or promatect 100 thickness 12 mm |
| 4. Rock wool, 40 kg/m <sup>3</sup>  | 9. Self-drilling screw $\varnothing$ 3,5 X 45 mm                                |
| 5. Terminal valve   | D from nominal diameter min + 50 to nominal diameter max + 70                   |

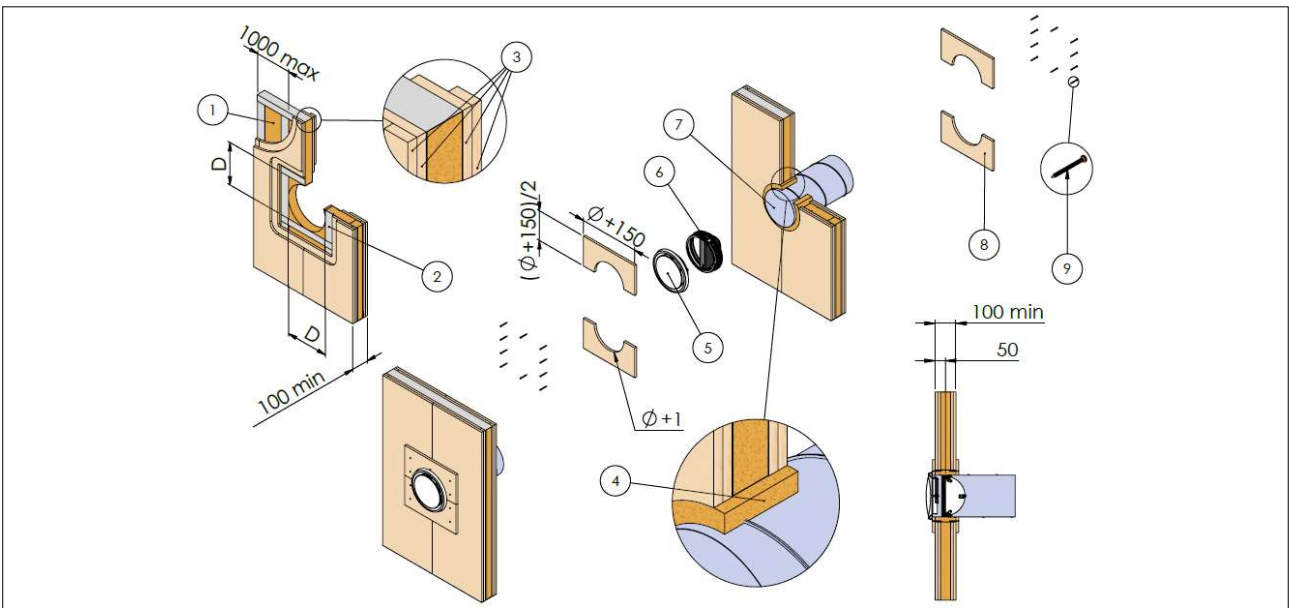

**Light wall, transfer, round hole, rock wool with plasterboard**

- |   |   |
|---|---|
| 1. Rock wool density up to 40 kg/m <sup>3</sup> (optional)                      | 6. Fire damper  |
| 2. Metal frame  | 7. Ventilation duct   |
| 3. plasterboard, thickness 12,5 mm type A: FBC1; type F: FBC4 and FBC7 (EN 520) | 8. Plasterboard arch infill, thickness 12,5 mm or promatect 100 thickness 12 mm |
| 4. Rock wool, 40 kg/m <sup>3</sup>  | 9. Self-drilling screw $\varnothing$ 3,5 X 45 mm                                |
| 5. Terminal valve   | D from nominal diameter min + 50 to nominal diameter max + 70                   |

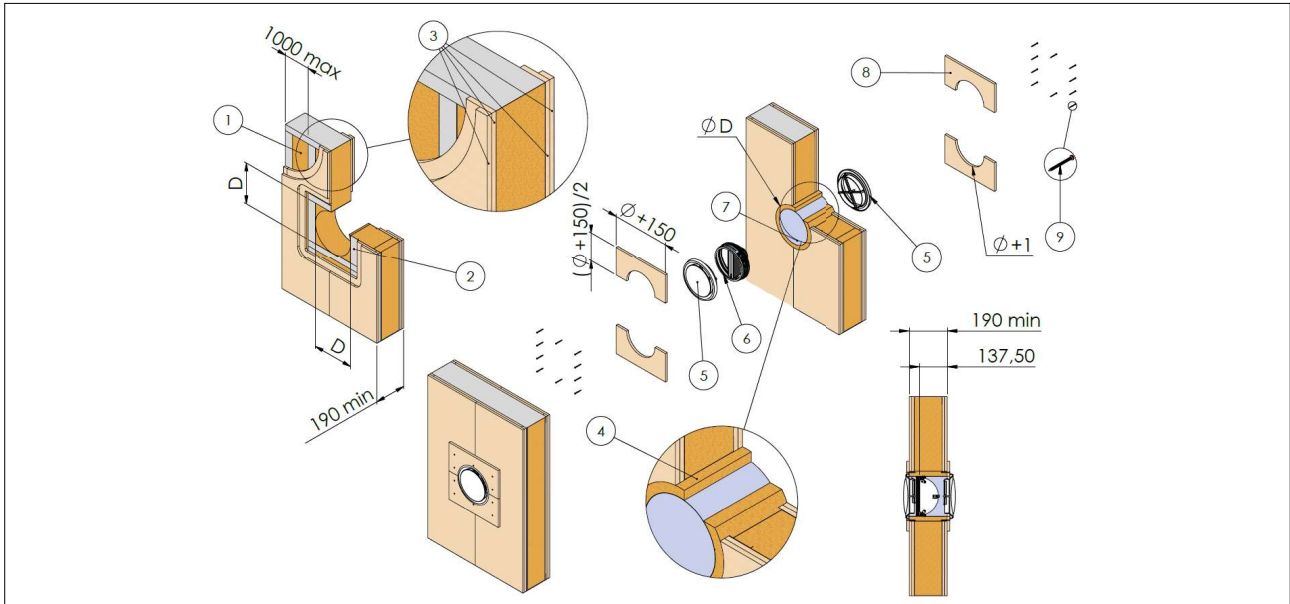



### 3.9. Vertical gypsum block wall installation (carreaux de plâtre)

See section Construction supports characteristics for more details, observe the minimum distances indicated in section Minimum distances, carry out a functional test before and after installation. See section for more details.

#### 3.9.1. Wall opening

A opening must be provided in the wall as indicated in the drawing.

#### 3.9.2. Damper positioning

Install the fire damper in the ventilation duct as shown in the drawing. Close the blade before installing the fire damper

#### 3.9.3. Filling

Fill the space between ventilation duct and wall as indicated in the drawing.

#### 3.9.4. Insulation

The walls must be of the same or higher strength class than the damper.

#### Plaster block wall, ducted on both sides, square hole, mortar or gypsum plaster

1. Mortar or plaster grouting
2. Fire damper
3. Ventilation duct

4. Vertical plaster block wall
- D from nominal diameter min + 50 to nominal diameter max + 70

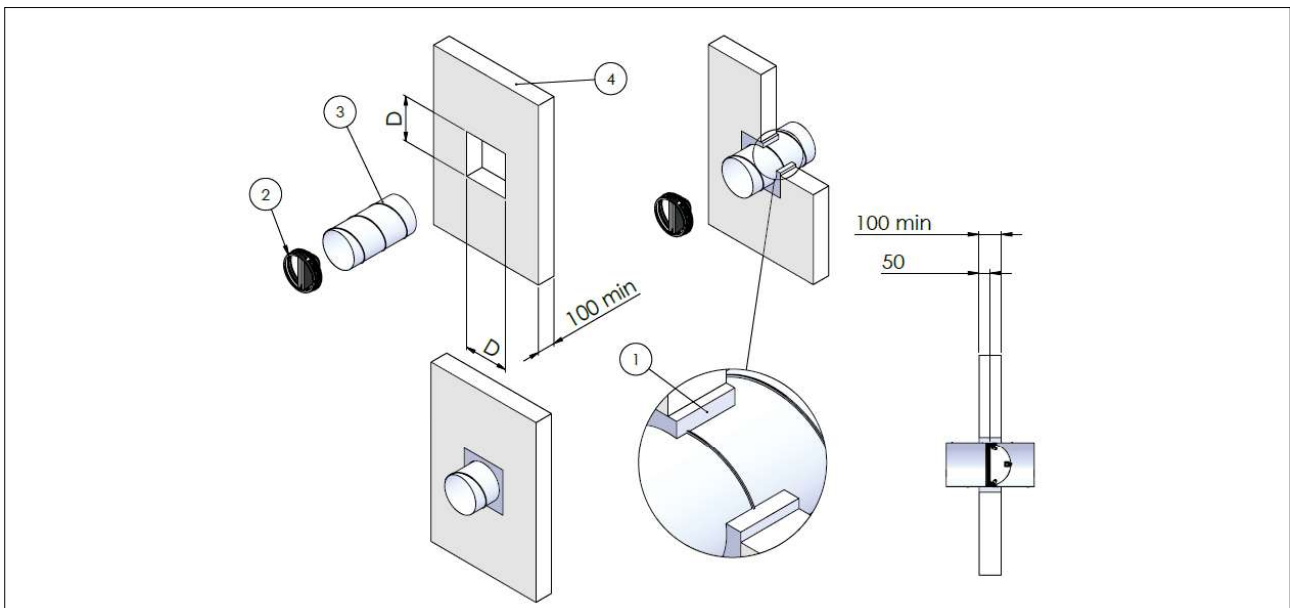

**Plaster block wall, ducted one side, square hole, mortar or plaster putty**

1. Mortar or plaster grouting
2. Terminal valve
3. Fire damper

4. Ventilation duct
5. Vertical plaster block wall
- D from nominal diameter min + 50 to nominal diameter max + 70

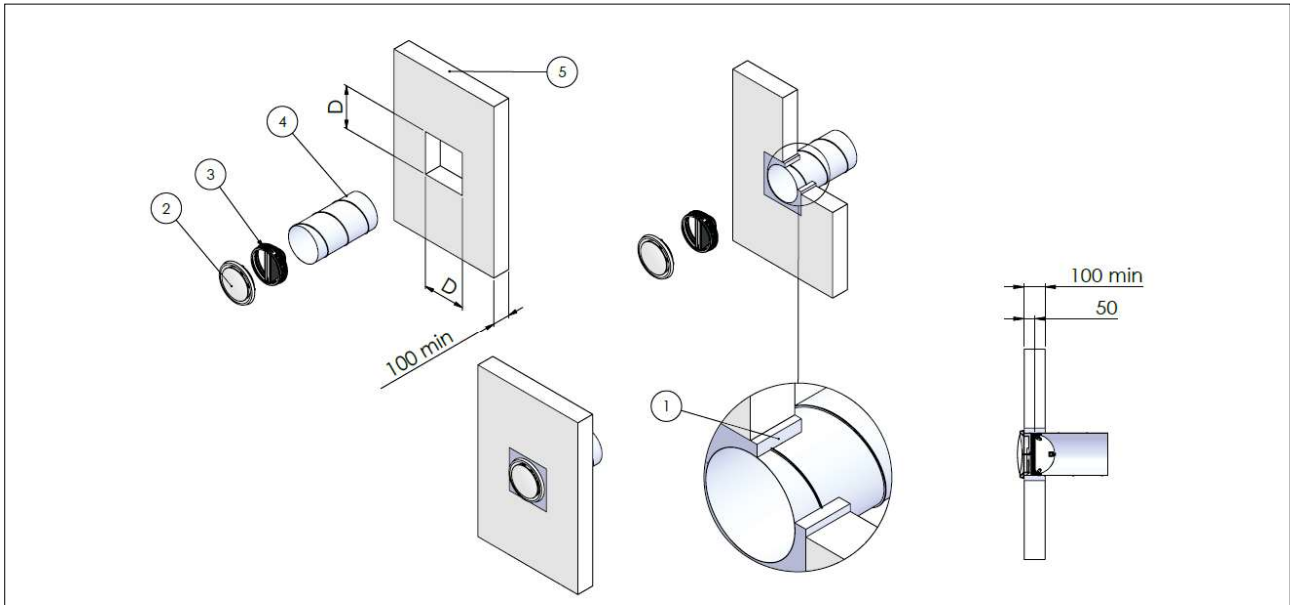

**Plaster block wall, transfer, square hole, mortar or plaster putty**

1. Mortar or plaster grouting
2. Terminal valve
3. Fire damper

4. Ventilation duct
5. Vertical plaster block wall
- D from nominal diameter min + 50 to nominal diameter max + 70

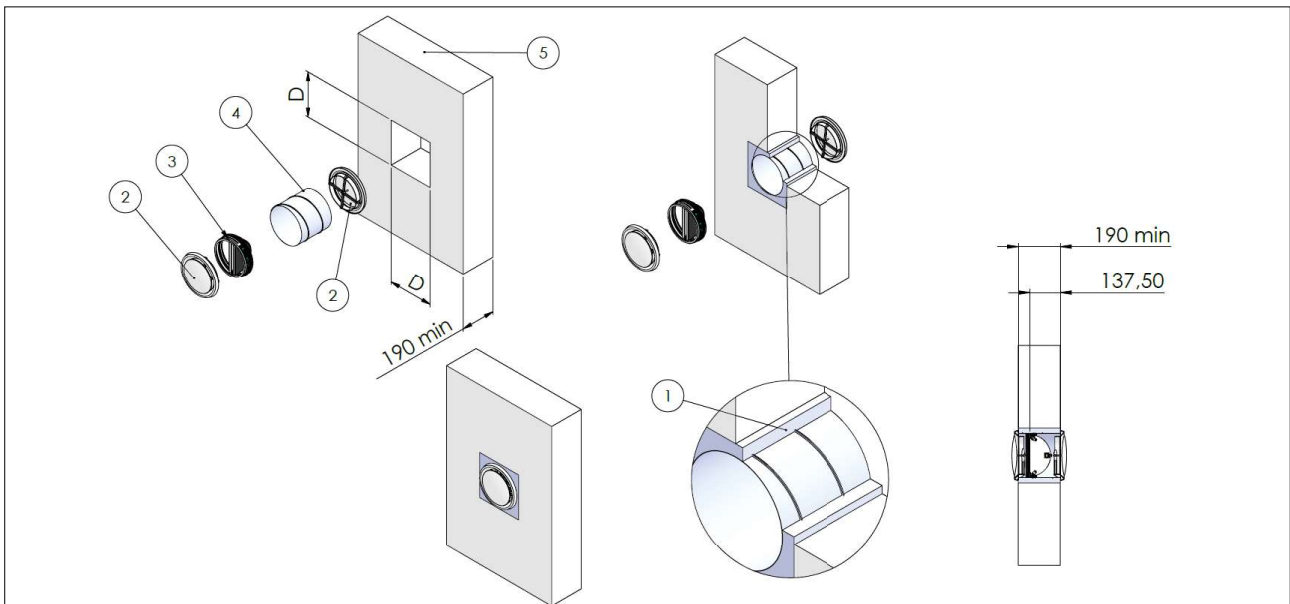

**Plaster block wall, ducted both sides, square hole, rock wool with mortar or plaster putty**

- |                                    |   |
|------------------------------------|---|
| 1. Rock wool, 40 kg/m <sup>3</sup> | 4. Ventilation duct   |
| 2. Mortar or plaster grouting      | 5. Vertical plaster block wall                                |
| 3. Fire damper                     | D from nominal diameter min + 50 to nominal diameter max + 70 |

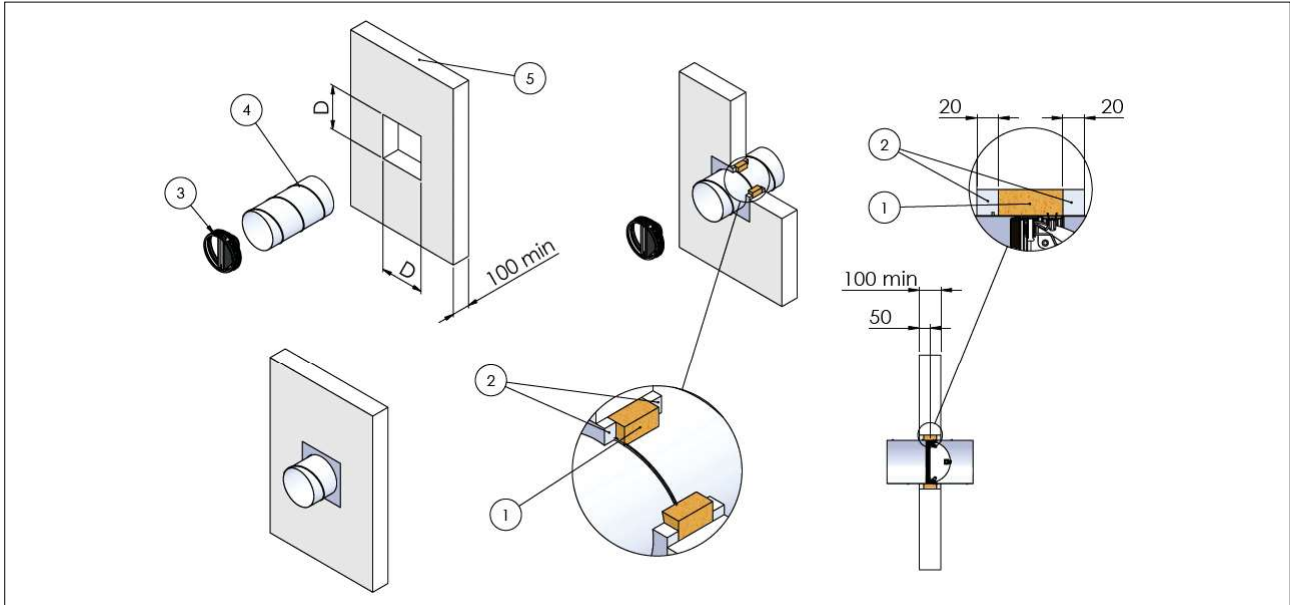

**Plaster block wall, ducted one side, square hole, rock wool with mortar or plaster putty**

- |                                    |   |
|------------------------------------|---|
| 1. Rock wool, 40 kg/m <sup>3</sup> | 5. Ventilation duct   |
| 2. Mortar or plaster grouting      | 6. Vertical plaster block wall                                |
| 3. Terminal valve                  | D from nominal diameter min + 50 to nominal diameter max + 70 |
| 4. Fire damper                     |   |

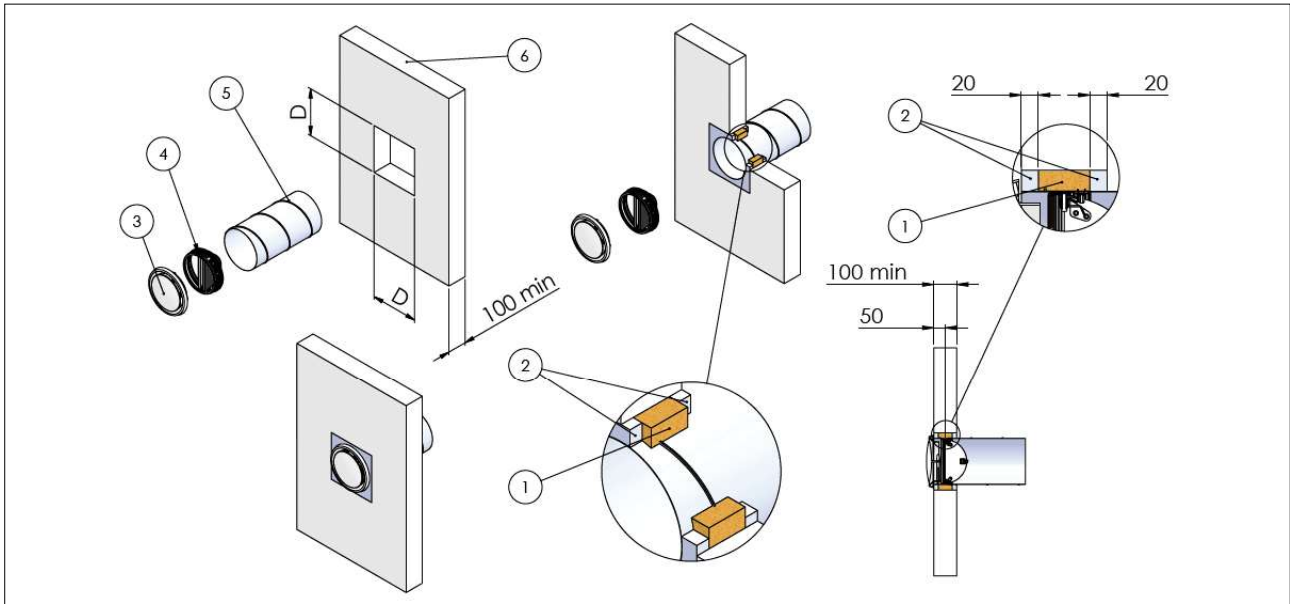

**plaster block wall, transfer, square hole, rock wool with mortar or plaster putty**

- |                                    |   |
|------------------------------------|---|
| 1. Mortar or plaster grouting      | 5. Ventilation duct   |
| 2. Rock wool, 40 kg/m <sup>3</sup> | 6. Vertical plaster block wall                                |
| 3. Terminal valve                  | D from nominal diameter min + 50 to nominal diameter max + 70 |
| 4. Fire damper                     |   |

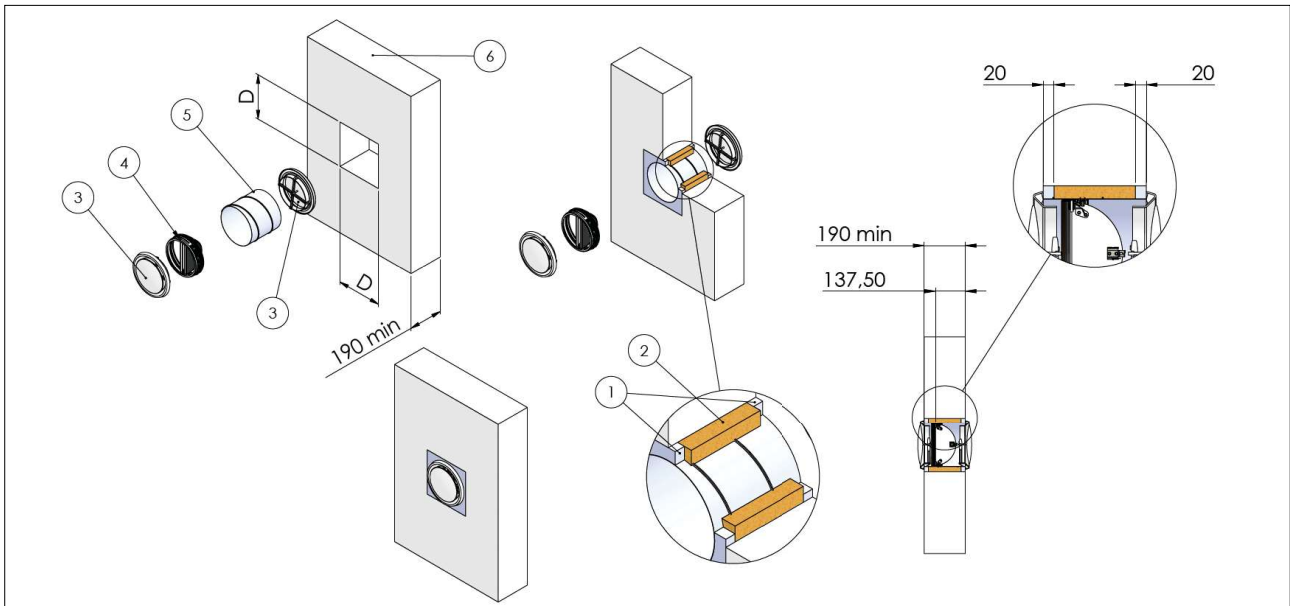

**Plaster block wall, ducted both sides, square hole, rock wool plasterboard - EI60-S - FBC1**

- |                                    |   |
|------------------------------------|---|
| 1. Rock wool, 40 kg/m <sup>3</sup> | 5. Plasterboard arch infill type A, thickness 12,5 mm or promactect 100 thickness 12 mm |
| 2. Fire damper                     | 6. Self-drilling screw Ø 3,5 X 45 mm  |
| 3. Ventilation duct                | D from nominal diameter min + 50 to nominal diameter max + 70                           |
| 4. Vertical plaster block wall     |   |

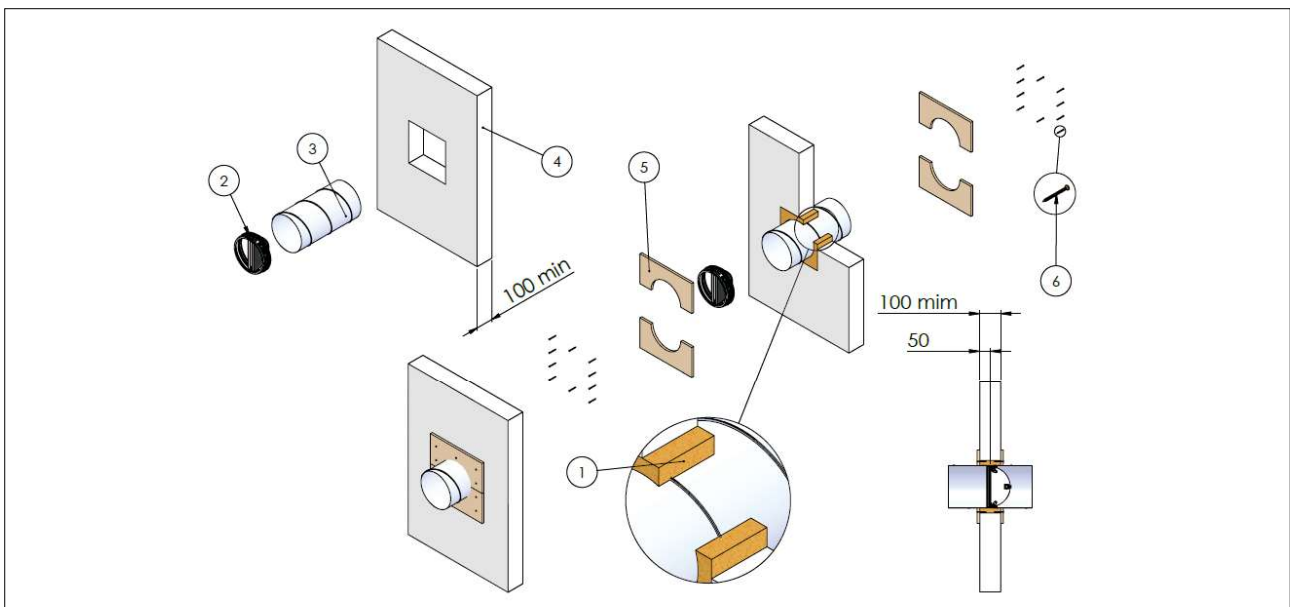

**Plaster block wall, ducted both sides, square hole, rock wool plasterboard - EI90-S - FBC4- EI120-S - FBC7**

- |                                    |   |
|------------------------------------|---|
| 1. Rock wool, 40 kg/m <sup>3</sup> | 5. Plasterboards arch infill type F, thickness 12,5 mm or promatect 100 thickness 12 mm |
| 2. Fire damper                     | 6. Self-drilling screw Ø 3,5 X 45 mm  |
| 3. Ventilation duct                | D from nominal diameter min + 50 to nominal diameter max + 70                           |
| 4. Vertical plaster block wall     |   |

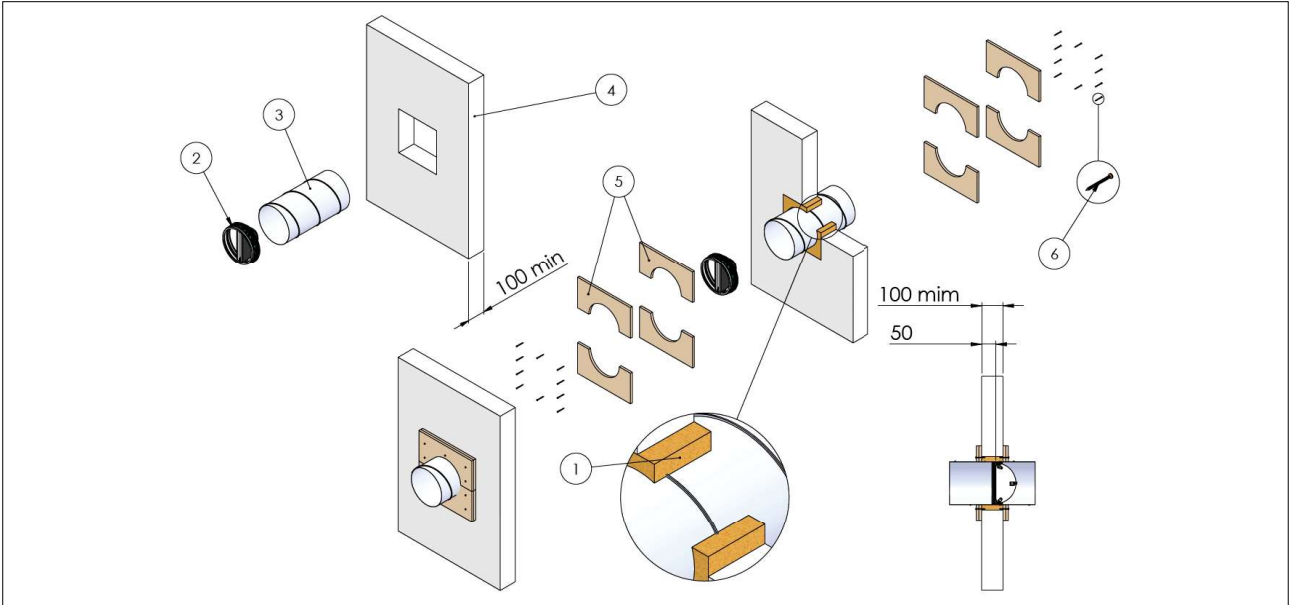

**Plaster block wall, ducted one side, square hole, rock wool with plasterboard**

- |                                    |   |
|------------------------------------|---|
| 1. Rock wool, 40 kg/m <sup>3</sup> | 6. Plasterboard arch infill, thickness 12,5 mm or promatect 100 thickness 12 mm |
| 2. Terminal valve                  | 7. Self-drilling screw Ø 3,5 X 45 mm  |
| 3. Fire damper                     | D from nominal diameter min + 50 to nominal diameter max + 70                   |
| 4. Ventilation duct                |   |
| 5. Vertical plaster block wall     |   |

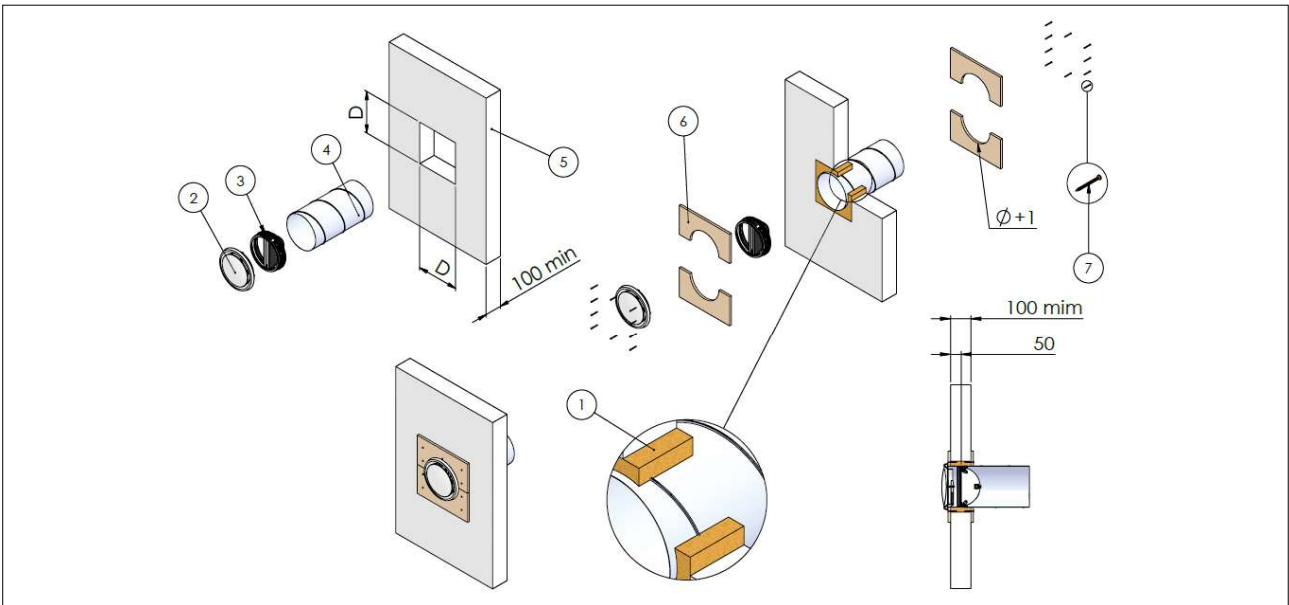

**Wall plaster blocks, transfer, square hole, rock wool plasterboard**

- |                                    |   |
|------------------------------------|---|
| 1. Rock wool, 40 kg/m <sup>3</sup> | 6. Plasterboard arch infill, thickness 12,5 mm or promatect 100 thickness 12 mm |
| 2. Terminal valve                  | 7. Self-drilling screw $\varnothing$ 3,5 X 45 mm                                |
| 3. Fire damper                     | D from nominal diameter min + 50 to nominal diameter max + 70                   |
| 4. Ventilation duct                |   |
| 5. Vertical plaster block wall     |   |

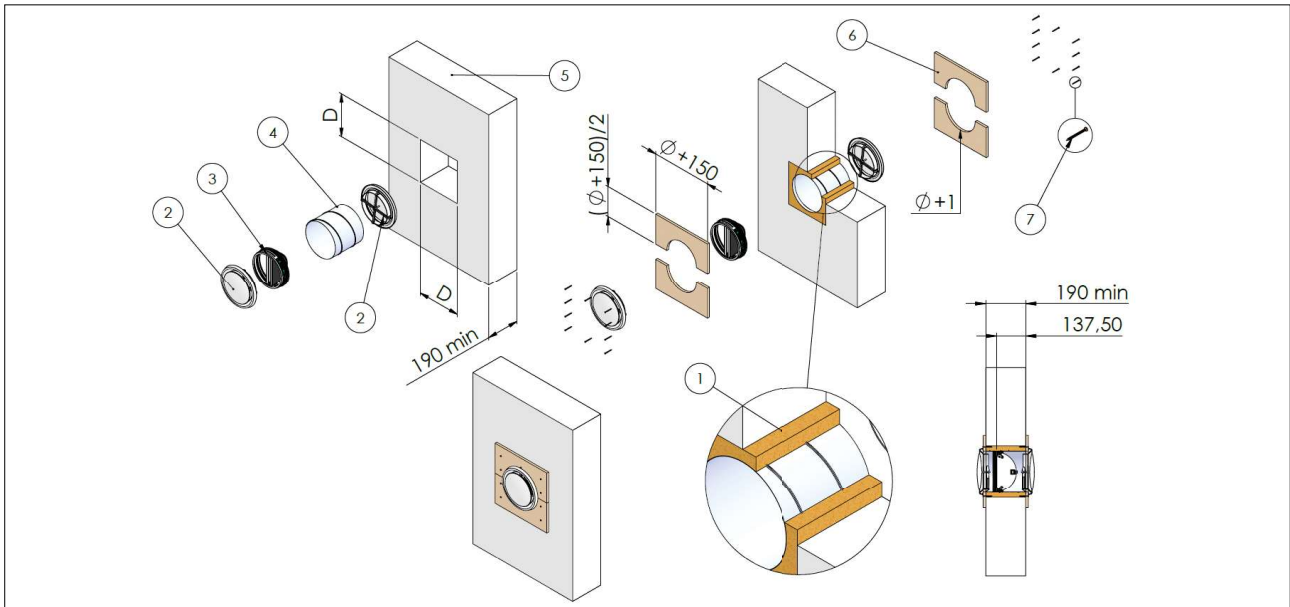

**Plaster block wall, ducted on both sides, circular hole, mortar or plaster putty**

- |                               |   |
|-------------------------------|---|
| 1. Mortar or plaster grouting | 4. Vertical plaster block wall                                |
| 2. Fire damper                | D from nominal diameter min + 50 to nominal diameter max + 70 |
| 3. Ventilation duct           |   |

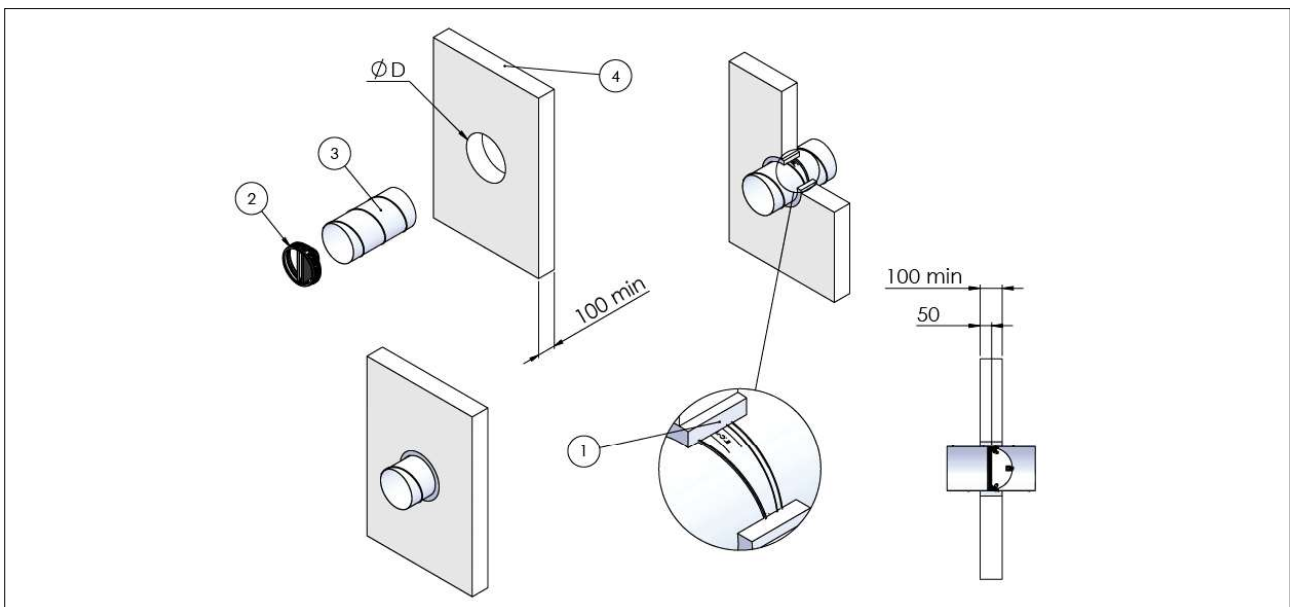

**Plaster block wall, ducted one side, circular hole, mortar or plaster putty**

- 1. Mortar or plaster grouting
- 2. Terminal valve
- 3. Fire damper

- 4. Ventilation duct
- 5. Vertical plaster block wall
- D from nominal diameter min + 50 to nominal diameter max + 70

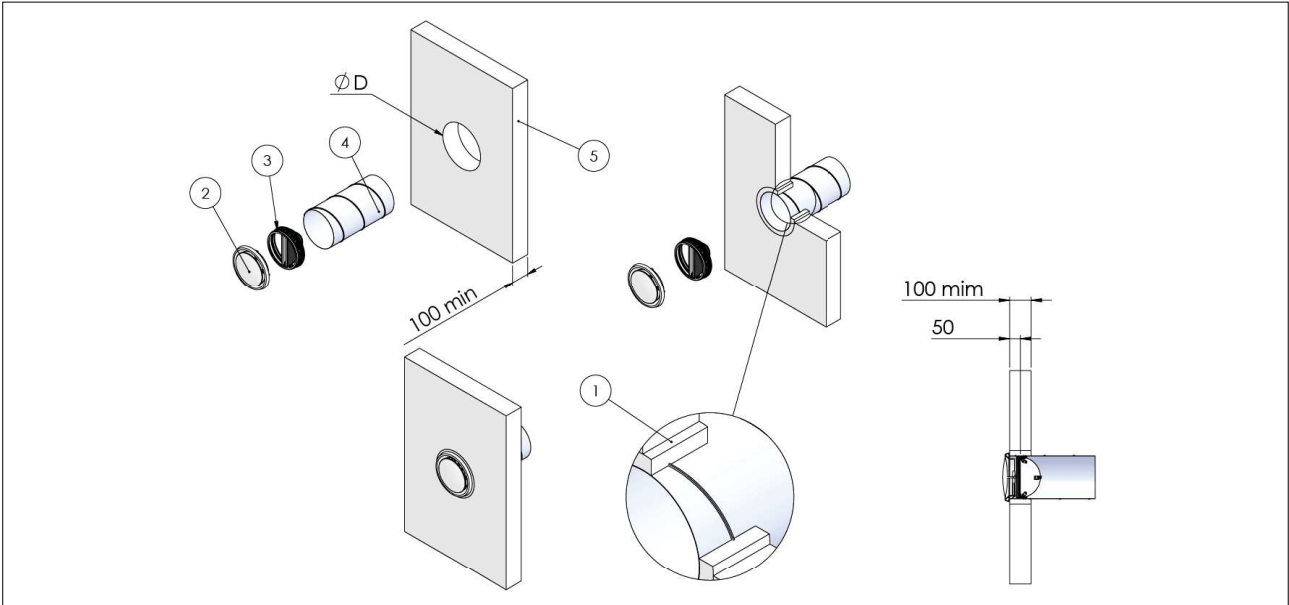

**Wall plaster blocks, transfer, circular hole, mortar or plaster putty**

- 1. Mortar or plaster grouting
- 2. Terminal valve
- 3. Fire damper

- 4. Ventilation duct
- 5. Vertical plaster block wall
- D from nominal diameter min + 50 to nominal diameter max + 70

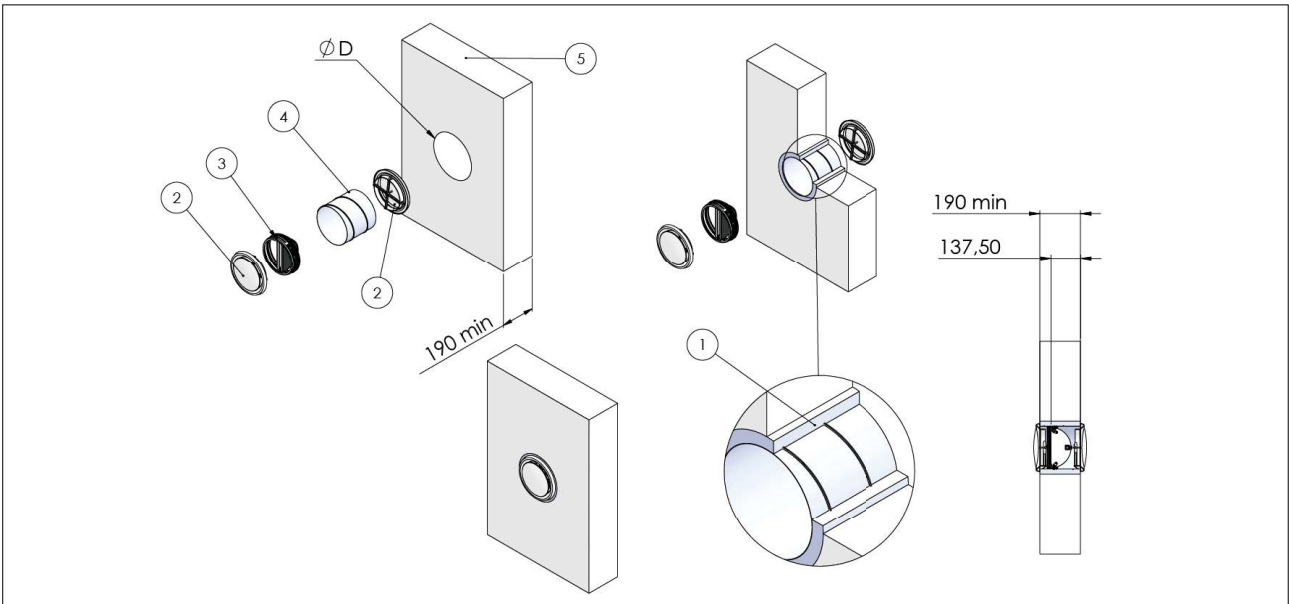



**Plaster block wall, ducted both sides, circular hole, rock wool with mortar or plaster putty**

- |                                    |   |
|------------------------------------|---|
| 1. Rock wool, 40 kg/m <sup>3</sup> | 4. Ventilation duct   |
| 2. Mortar or plaster grouting      | 5. Vertical plaster block wall                                |
| 3. Fire damper                     | D from nominal diameter min + 50 to nominal diameter max + 70 |

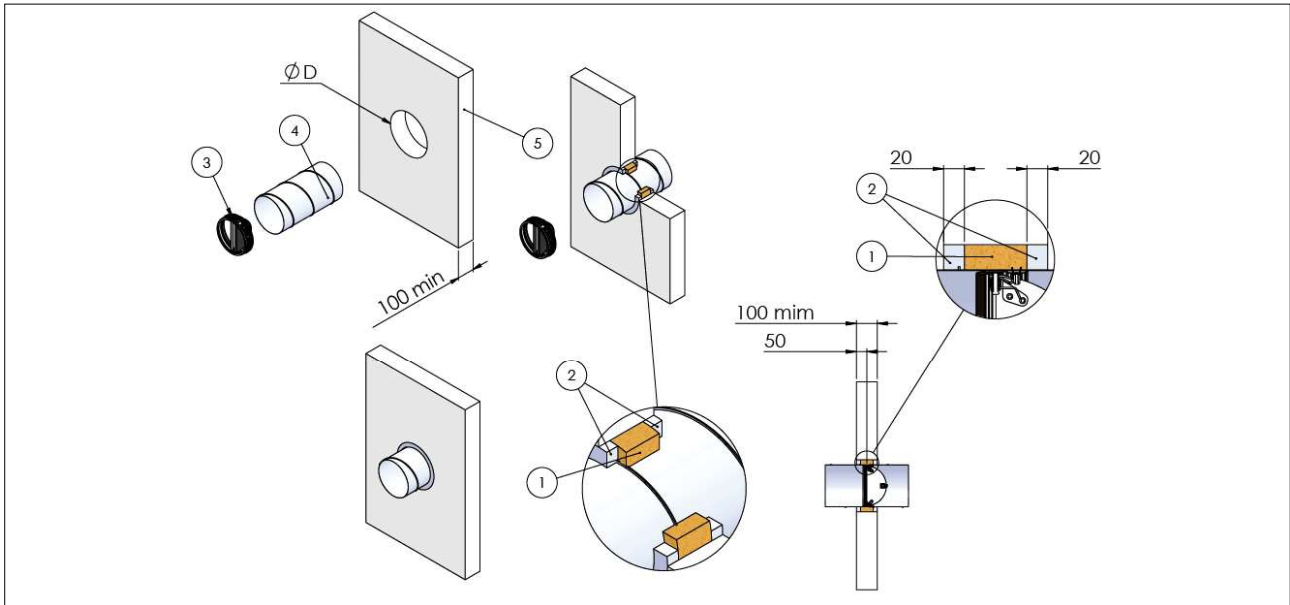

**Plaster block wall, ducted one side, circular hole, rock wool with mortar or plaster putty**

- |                                    |   |
|------------------------------------|---|
| 1. Rock wool, 40 kg/m <sup>3</sup> | 5. Ventilation duct   |
| 2. Mortar or plaster grouting      | 6. Vertical plaster block wall                                |
| 3. Terminal valve                  | D from nominal diameter min + 50 to nominal diameter max + 70 |
| 4. Fire damper                     |   |

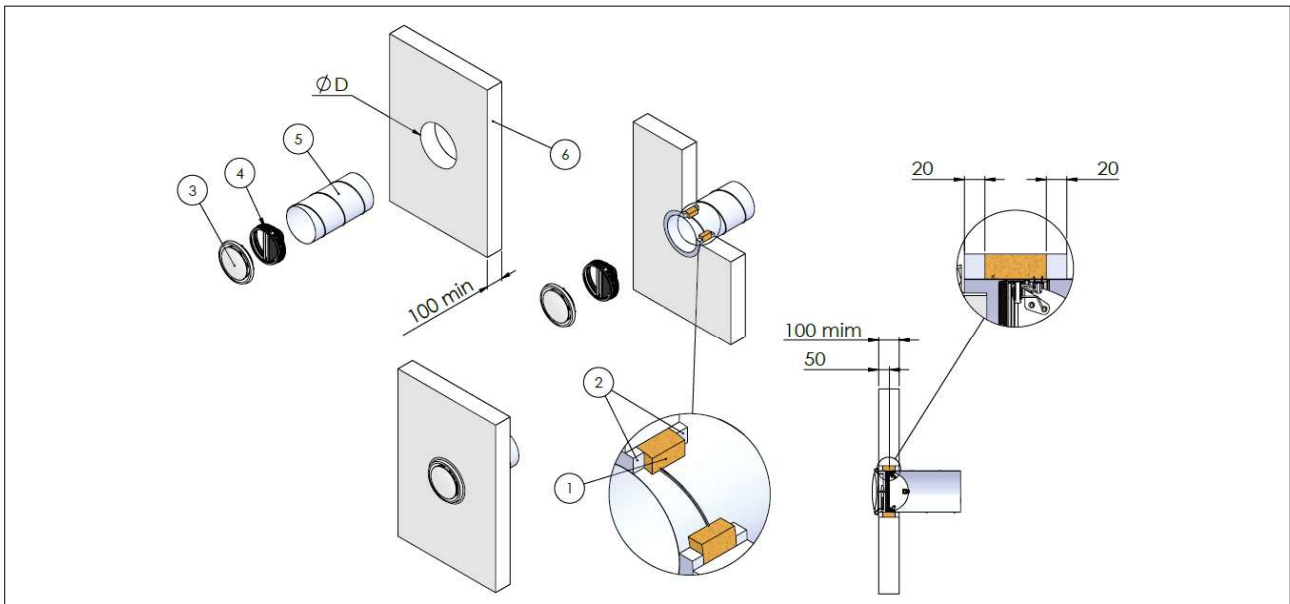

**Wall plaster blocks, transfer, round hole, rock wool with mortar or plaster putty**

- |    |                                 |    |   |
|----|---------------------------------|----|---|
| 1. | Mortar or plaster grouting      | 5. | Ventilation duct  |
| 2. | Rock wool, 40 kg/m <sup>3</sup> | 6. | Vertical plaster block wall                                 |
| 3. | Terminal valve                  | D  | from nominal diameter min + 50 to nominal diameter max + 70 |
| 4. | Fire damper                     |    |   |

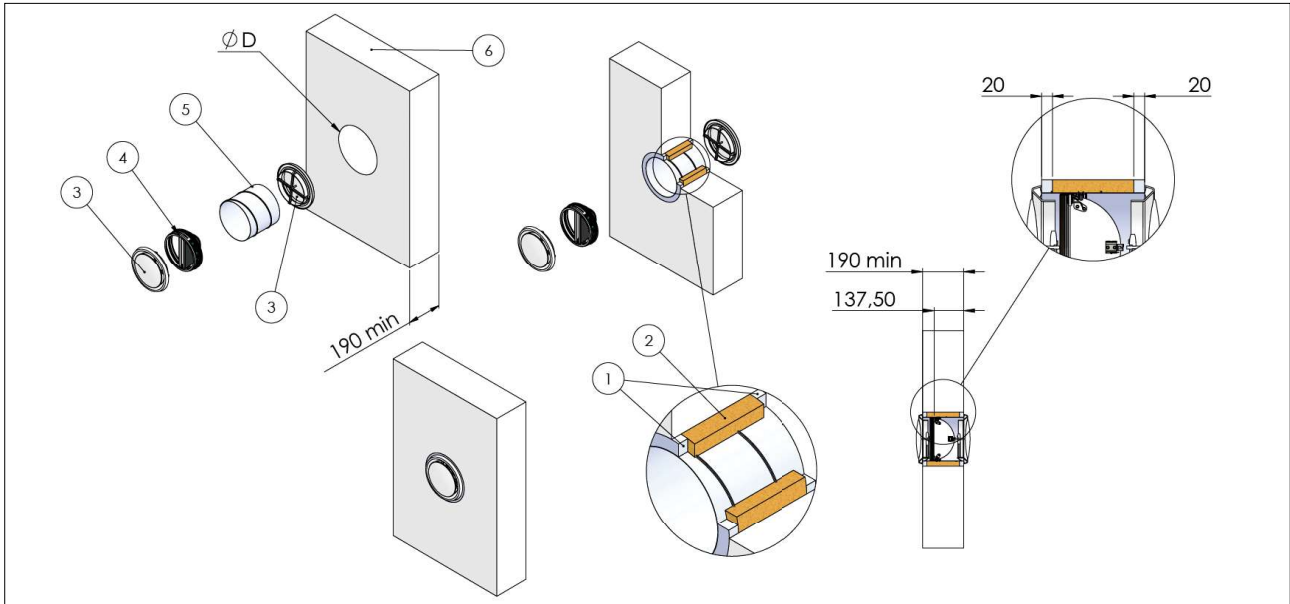

**Plaster block wall, ducted both sides, circular hole, rock wool with plasterboard - EI60-S - FBC1**

- |    |                                 |    |  |
|----|---------------------------------|----|--|
| 1. | Rock wool, 40 kg/m <sup>3</sup> | 5. | Plasterboard arch infill type A, thickness 12,5 mm or promactect 100 thickness 12 mm |
| 2. | Fire damper                     | 6. | Self-drilling screw Ø 3,5 X 45 mm  |
| 3. | Ventilation duct                | D  | from nominal diameter min + 50 to nominal diameter max + 70                          |
| 4. | Vertical plaster block wall     |    |  |

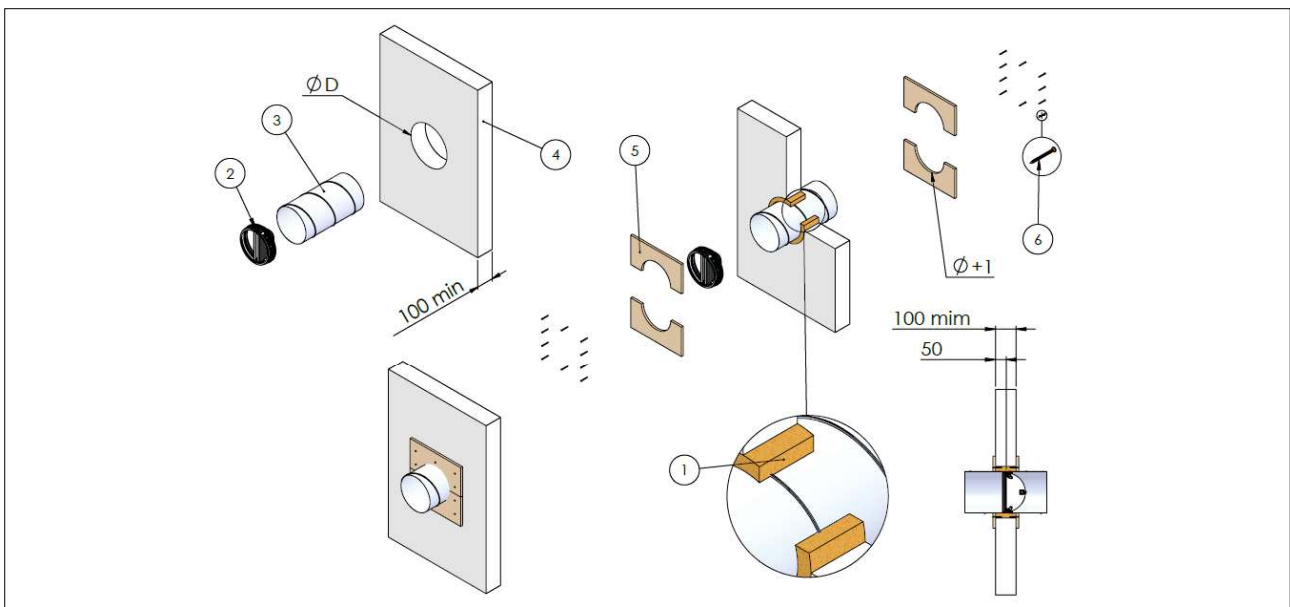

**Plaster block wall, ducted both sides, circular hole, rock wool plasterboard - EI90-S - FBC4- EI120-S - FBC7**

- |                                    |   |
|------------------------------------|---|
| 1. Rock wool, 40 kg/m <sup>3</sup> | 5. Plasterboards arch infill type F, thickness 12,5 mm or promatect 100 thickness 12 mm |
| 2. Fire damper                     | 6. Self-drilling screw Ø 3,5 X 45 mm  |
| 3. Ventilation duct                | D from nominal diameter min + 50 to nominal diameter max + 70                           |
| 4. Vertical plaster block wall     |   |

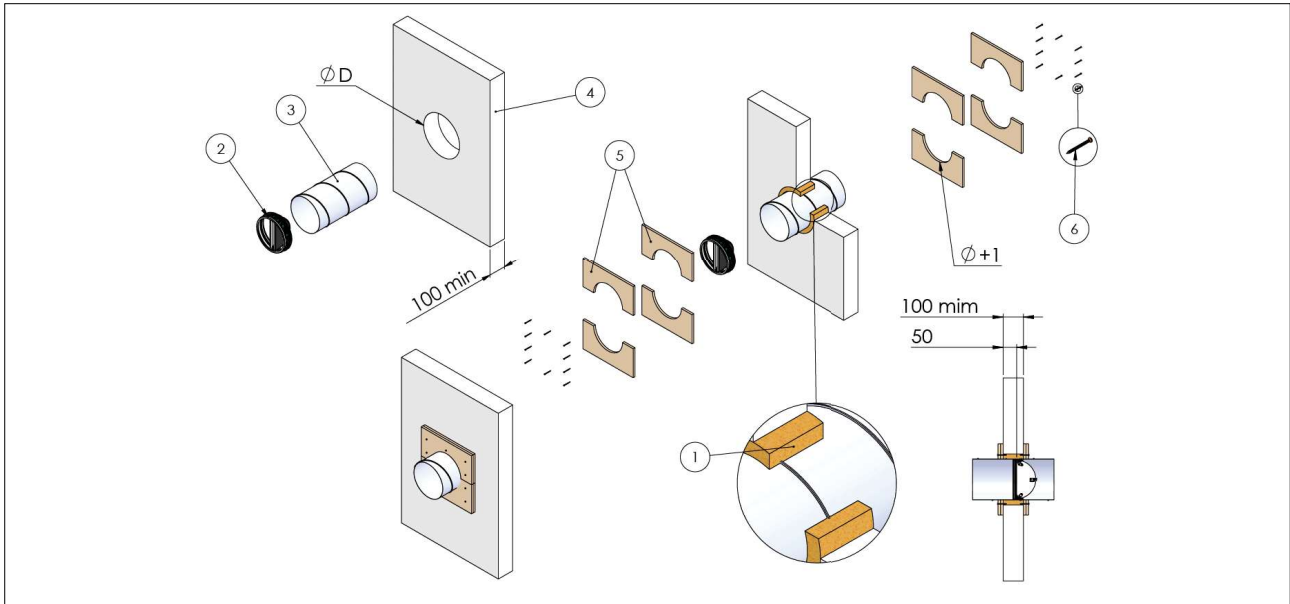

**Plaster block wall, ducted one side, circular hole, rock wool with plasterboard**

- |                                    |   |
|------------------------------------|---|
| 1. Rock wool, 40 kg/m <sup>3</sup> | 6. Plasterboard arch infill, thickness 12,5 mm or promatect 100 thickness 12 mm |
| 2. Terminal valve                  | 7. Self-drilling screw Ø 3,5 X 45 mm  |
| 3. Fire damper                     | D from nominal diameter min + 50 to nominal diameter max + 70                   |
| 4. Ventilation duct                |   |
| 5. Vertical plaster block wall     |   |

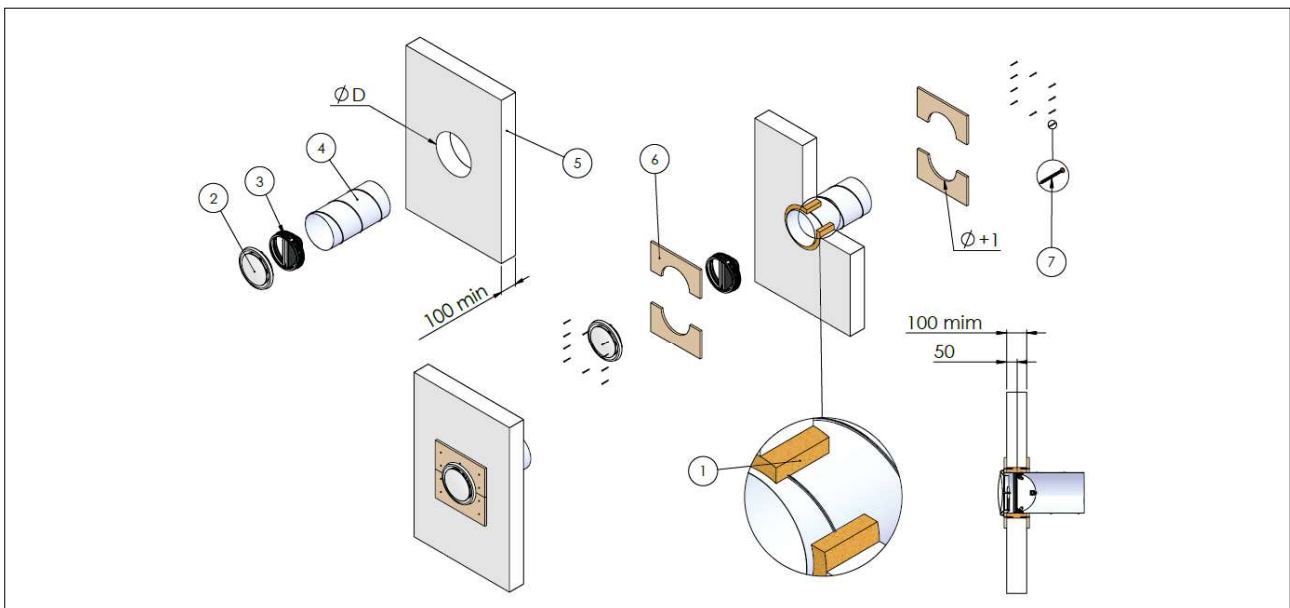

**Plaster block wall, transfer, round hole, rock wool with plasterboard**

- |                                    |  |
|------------------------------------|--|
| 1. Rock wool, 40 kg/m <sup>3</sup> | 6. Plasterboard arch infill, thickness 12,5 mm or promatect 100<br>thickness 12 mm |
| 2. Terminal valve                  | 7. Self-drilling screw Ø 3,5 X 45 mm   |
| 3. Fire damper                     | D from nominal diameter min + 50 to nominal diameter max + 70                      |
| 4. Ventilation duct                |  |
| 5. Vertical plaster block wall     |  |

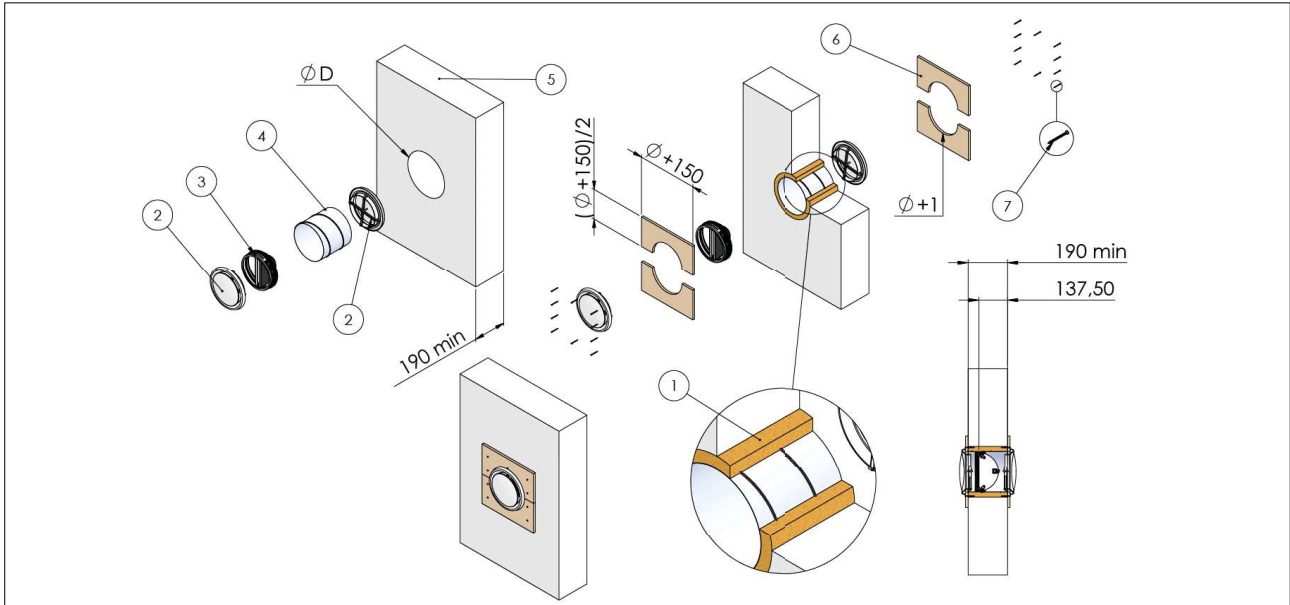

### 3.10. Lightweight vertical security wall installations (plasterboard) - (Firewall / Brandwande)

See section Construction supports characteristics for more details, observe the minimum distances indicated in section Minimum distances, carry out a functional test before and after installation. See section for more details.

#### 3.10.1. Wall opening

A opening must be provided in the wall as indicated in the drawing.

#### 3.10.2. Damper positioning

Install the fire damper in the ventilation duct as shown in the drawing. Close the blade before installing the fire damper

#### 3.10.3. Filling

Fill the space between ventilation duct and wall as indicated in the drawing.

#### 3.10.4. Insulation

Only in the case of light vertical walls, with two dampers closer than 200 mm and rock wool sealing, BELT-FBC-Ø bands (see section Accessories and spare parts) are required, which are applied to the duct on both sides of the wall or cavity on the accessible side only. With grout or mortar sealing, the strips are NEVER necessary.

The shafts walls shall have fire resistance equal or higher to the one of the fire damper.

#### Lightweight safety wall, ducted on both sides, square hole, mortar or gypsum plaster

- |   |   |
|---|---|
| 1. Rock wool density up to 40 kg/m <sup>3</sup> (optional)                      | 5. Mortar or plaster putty                                    |
| 2. Metal frame  | 6. Fire damper  |
| 3. plasterboard, thickness 12,5 mm type A: FBC1; type F: FBC4 and FBC7 (EN 520) | 7. Ventilation duct   |
| 4. Metal foil 0.5 mm thick  | D from nominal diameter min + 50 to nominal diameter max + 70 |

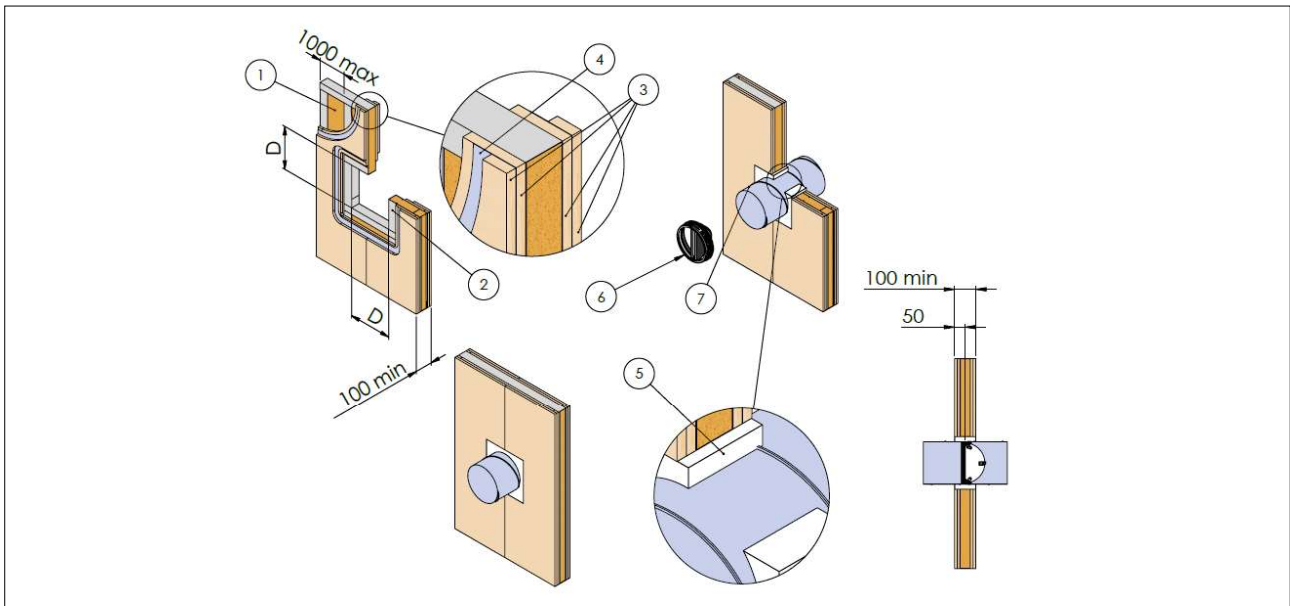

**Lightweight safety wall, ducted one side, square hole, mortar or plaster putty**

- |   |   |
|---|---|
| 1. Rock wool density up to 40 kg/m <sup>3</sup> (optional)                      | 5. Mortar or plaster putty                                    |
| 2. Metal frame  | 6. Terminal valve   |
| 3. plasterboard, thickness 12,5 mm type A: FBC1; type F: FBC4 and FBC7 (EN 520) | 7. Fire damper  |
| 4. Metal foil 0.5 mm thick  | 8. Ventilation duct   |
|   | D from nominal diameter min + 50 to nominal diameter max + 70 |

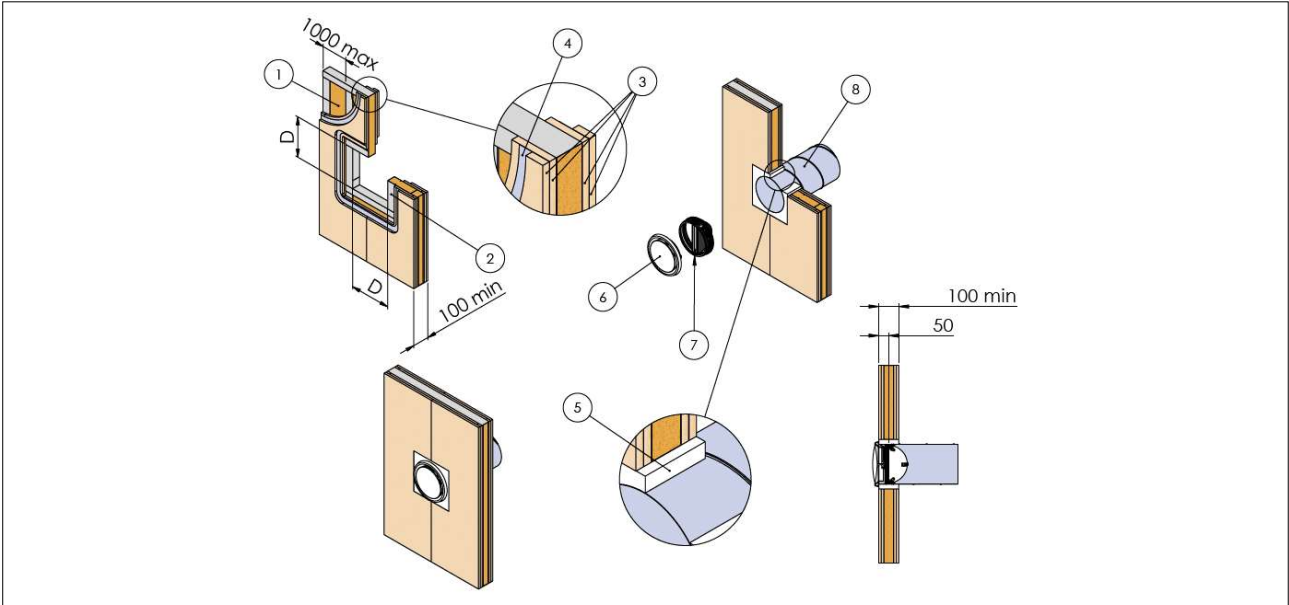

**Light security wall, transfer, square hole, mortar or plaster putty**

- |   |   |
|---|---|
| 1. Rock wool density up to 40 kg/m <sup>3</sup> (optional)                      | 5. Mortar or plaster putty                                    |
| 2. Metal frame  | 6. Terminal valve   |
| 3. plasterboard, thickness 12,5 mm type A: FBC1; type F: FBC4 and FBC7 (EN 520) | 7. Fire damper  |
| 4. Metal foil 0.5 mm thick  | 8. Ventilation duct   |
|   | D from nominal diameter min + 50 to nominal diameter max + 70 |

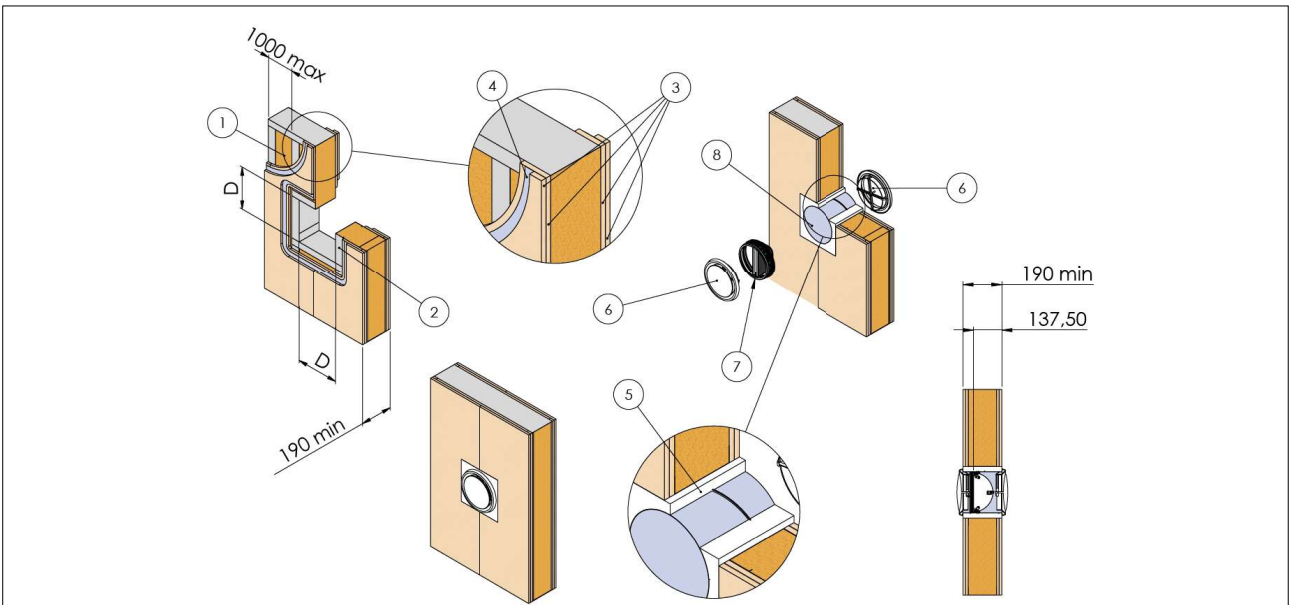

**Light safety wall, ducted both sides, square hole, rock wool with mortar or gypsum plaster**

- |   |   |
|---|---|
| 1. Rock wool density up to 40 kg/m <sup>3</sup> (optional)                      | 5. Mortar or plaster putty                                    |
| 2. Metal frame  | 6. Rock wool, 40 kg/m <sup>3</sup>                            |
| 3. plasterboard, thickness 12,5 mm type A: FBC1; type F: FBC4 and FBC7 (EN 520) | 7. Fire damper  |
| 4. Foil thickness 0.5 mm  | 8. Ventilation duct   |
|   | D from nominal diameter min + 50 to nominal diameter max + 70 |

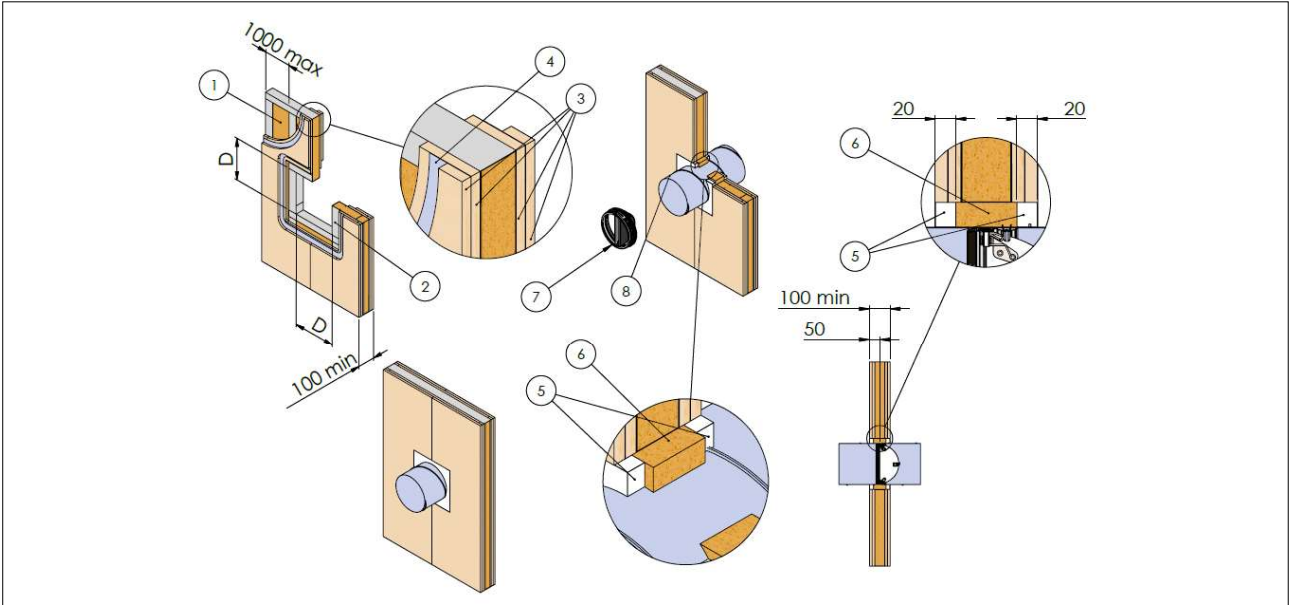

**Light safety wall, ducted one side, square hole, rock wool with mortar or gypsum plaster**

- |   |   |
|---|---|
| 1. Rock wool density up to 40 kg/m <sup>3</sup> (optional)                      | 6. Rock wool, 40 kg/m <sup>3</sup>                            |
| 2. Metal frame  | 7. Terminal valve   |
| 3. plasterboard, thickness 12,5 mm type A: FBC1; type F: FBC4 and FBC7 (EN 520) | 8. Fire damper  |
| 4. Foil thickness 0.5 mm  | 9. Ventilation duct   |
| 5. Mortar or plaster putty  | D from nominal diameter min + 50 to nominal diameter max + 70 |

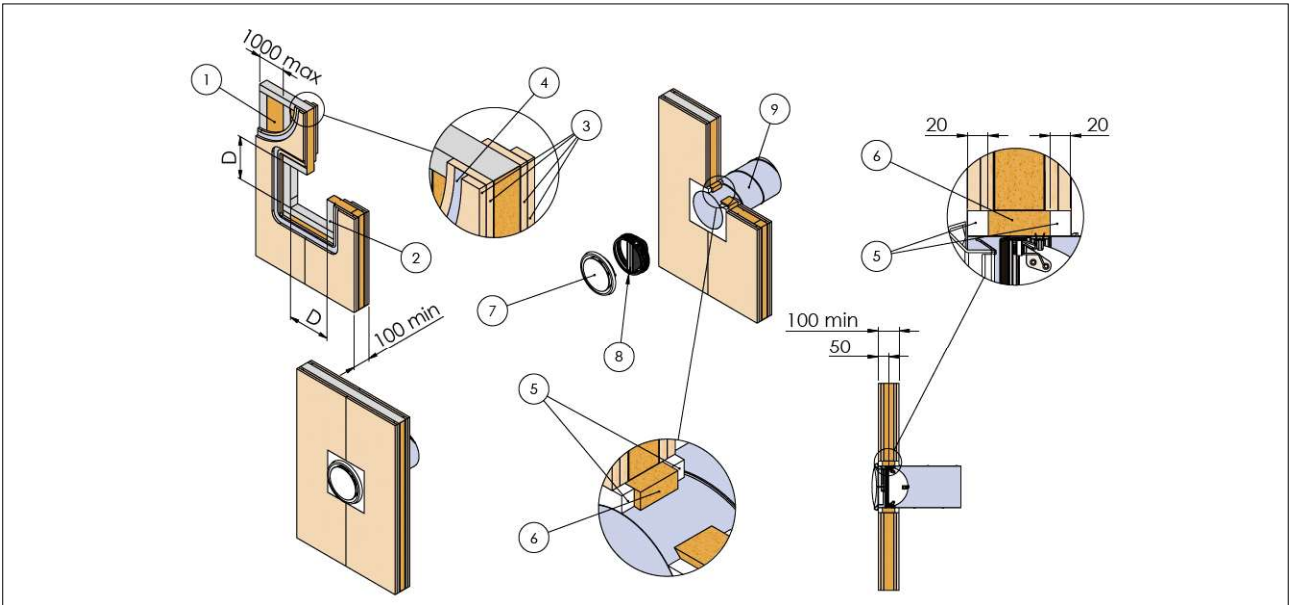



**Light wall, transfer, square hole, rock wool with mortar or plaster putty**

- |   |   |
|---|---|
| 1. Rock wool density up to 40 kg/m <sup>3</sup> (optional)                      | 6. Rock wool, 40 kg/m <sup>3</sup>                            |
| 2. Metal frame  | 7. Terminal valve   |
| 3. plasterboard, thickness 12,5 mm type A: FBC1; type F: FBC4 and FBC7 (EN 520) | 8. Fire damper  |
| 4. Foil thickness 0.5 mm  | 9. Ventilation duct   |
| 5. Mortar or plaster putty  | D from nominal diameter min + 50 to nominal diameter max + 70 |

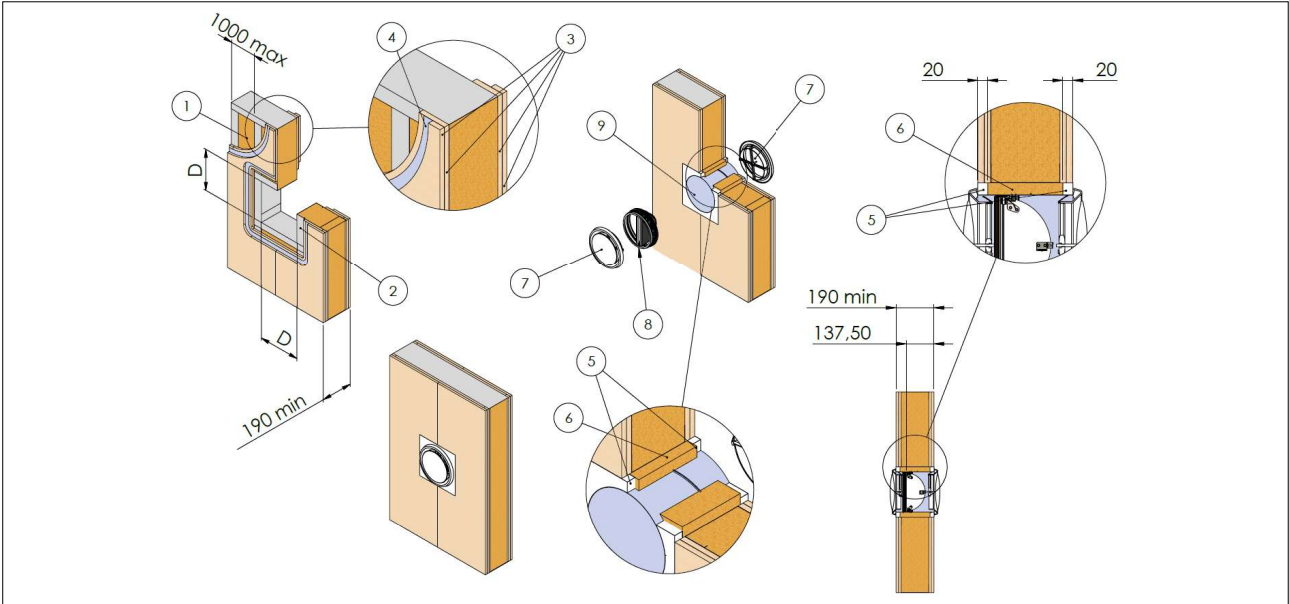

**Light safety wall, ducted both sides, square hole, rock wool with plasterboard - EI60-S - FBC1**

- |   |  |
|---|--|
| 1. Rock wool density up to 40 kg/m <sup>3</sup> (optional)                      | 6. Fire damper   |
| 2. Metal frame  | 7. Ventilation duct  |
| 3. plasterboard, thickness 12,5 mm type A: FBC1; type F: FBC4 and FBC7 (EN 520) | 8. Plasterboard arch infill type A, thickness 12,5 mm or promatect 100 thickness 12 mm |
| 4. Foil thickness 0.5 mm  | 9. Self-drilling screw Ø 3,5 X 45 mm   |
| 5. Rock wool, 40 kg/m <sup>3</sup>  | D from nominal diameter min + 50 to nominal diameter max + 70                          |

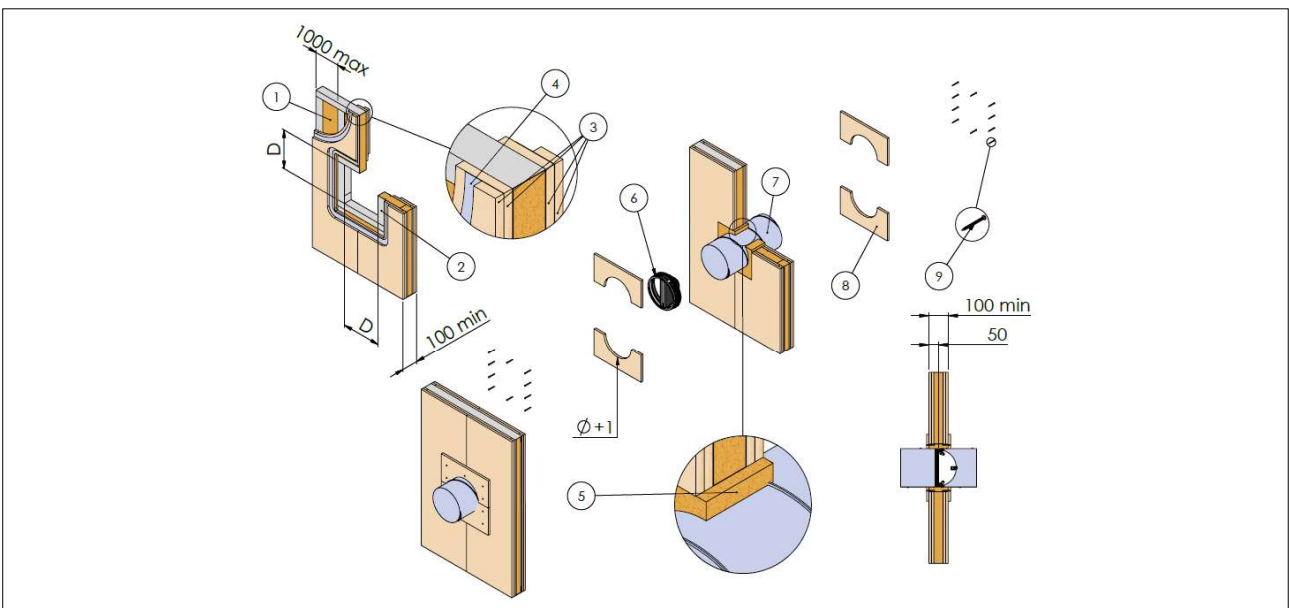

**Light safety wall, ducted both sides, square hole, rock wool with plasterboard - EI90-S - FBC4- EI120-S - FBC7**

- |   |   |
|---|---|
| 1. Rock wool density up to 40 kg/m <sup>3</sup> (optional)                      | 6. Fire damper  |
| 2. Metal frame  | 7. Ventilation duct   |
| 3. plasterboard, thickness 12,5 mm type A: FBC1; type F: FBC4 and FBC7 (EN 520) | 8. Plasterboards arch infill type F, thickness 12,5 mm or promatect 100 thickness 12 mm |
| 4. Foil thickness 0.5 mm  | 9. Self-drilling screw Ø 3,5 X 45 mm  |
| 5. Rock wool, 40 kg/m <sup>3</sup>  | D from nominal diameter min + 50 to nominal diameter max + 70                           |

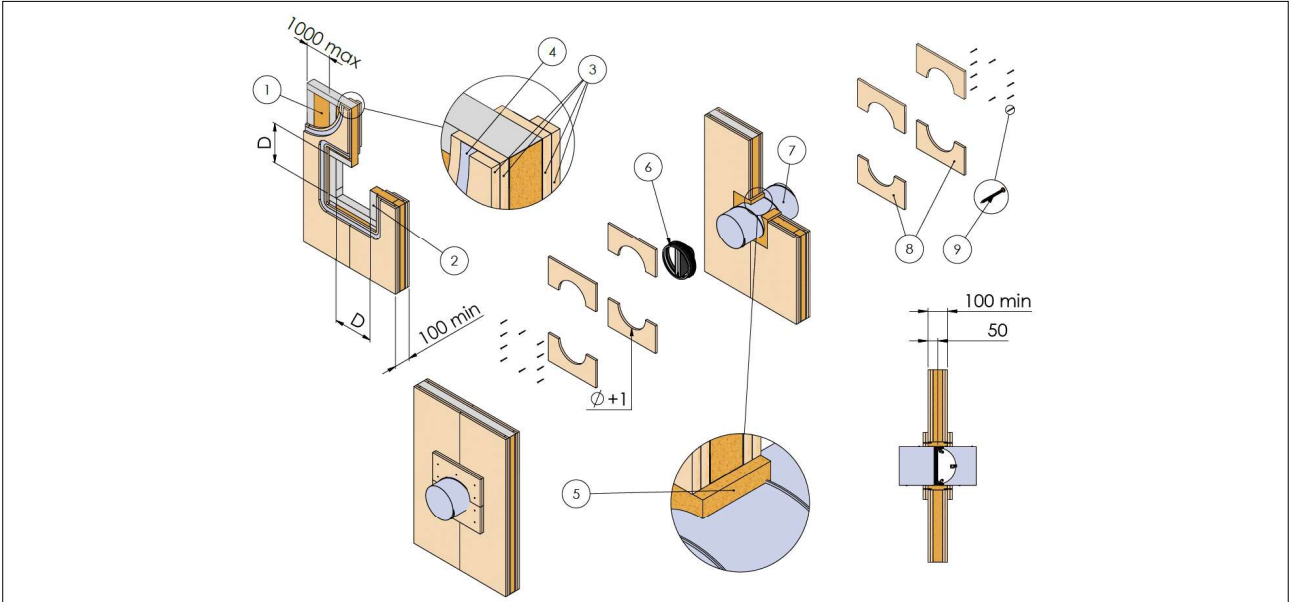

**Light safety wall, ducted one side, square hole, rock wool with plasterboard**

- |   |   |
|---|---|
| 1. Rock wool density up to 40 kg/m <sup>3</sup> (optional)                      | 7. Fire damper  |
| 2. Metal frame  | 8. Ventilation duct   |
| 3. plasterboard, thickness 12,5 mm type A: FBC1; type F: FBC4 and FBC7 (EN 520) | 9. Plasterboard arch infill, thickness 12,5 mm or promatect 100 thickness 12 mm |
| 4. Foil thickness 0.5 mm  | 10. Self-drilling screw Ø 3,5 X 45 mm   |
| 5. Rock wool, 40 kg/m <sup>3</sup>  | D from nominal diameter min + 50 to nominal diameter max + 70                   |
| 6. Terminal valve   |   |

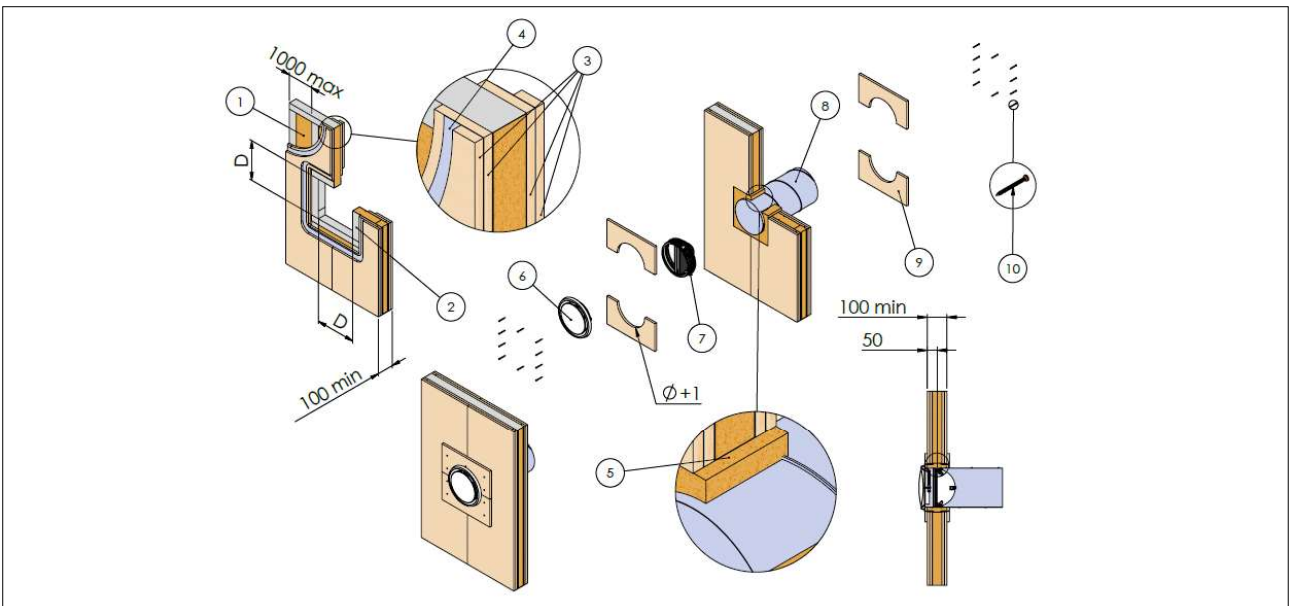

**Light safety wall, transfer, square hole, rock wool with plasterboard**

- |   |   |
|---|---|
| 1. Rock wool density up to 40 kg/m <sup>3</sup> (optional)                      | 7. Fire damper  |
| 2. Metal frame  | 8. Ventilation duct   |
| 3. plasterboard, thickness 12,5 mm type A: FBC1; type F: FBC4 and FBC7 (EN 520) | 9. Plasterboard arch infill, thickness 12,5 mm or promatect 100 thickness 12 mm |
| 4. Foil thickness 0.5 mm  | 10. Self-drilling screw Ø 3,5 X 45 mm   |
| 5. Rock wool, 40 kg/m <sup>3</sup>  | D from nominal diameter min + 50 to nominal diameter max + 70                   |
| 6. Terminal valve   |   |

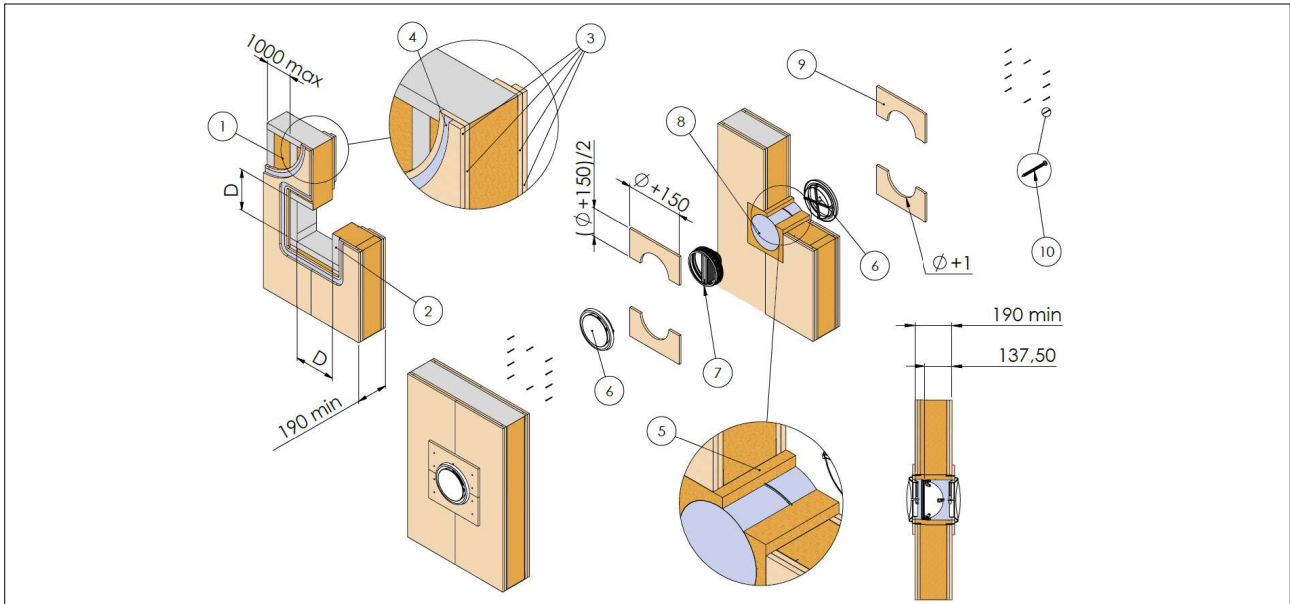

**Light safety wall, ducted on both sides, circular hole, mortar or plaster putty**

- |   |   |
|---|---|
| 1. Rock wool density up to 40 kg/m <sup>3</sup> (optional)                      | 5. Mortar or plaster putty                                    |
| 2. Metal frame  | 6. Fire damper  |
| 3. plasterboard, thickness 12,5 mm type A: FBC1; type F: FBC4 and FBC7 (EN 520) | 7. Ventilation duct   |
| 4. Metal foil 0.5 mm thick  | D from nominal diameter min + 50 to nominal diameter max + 70 |

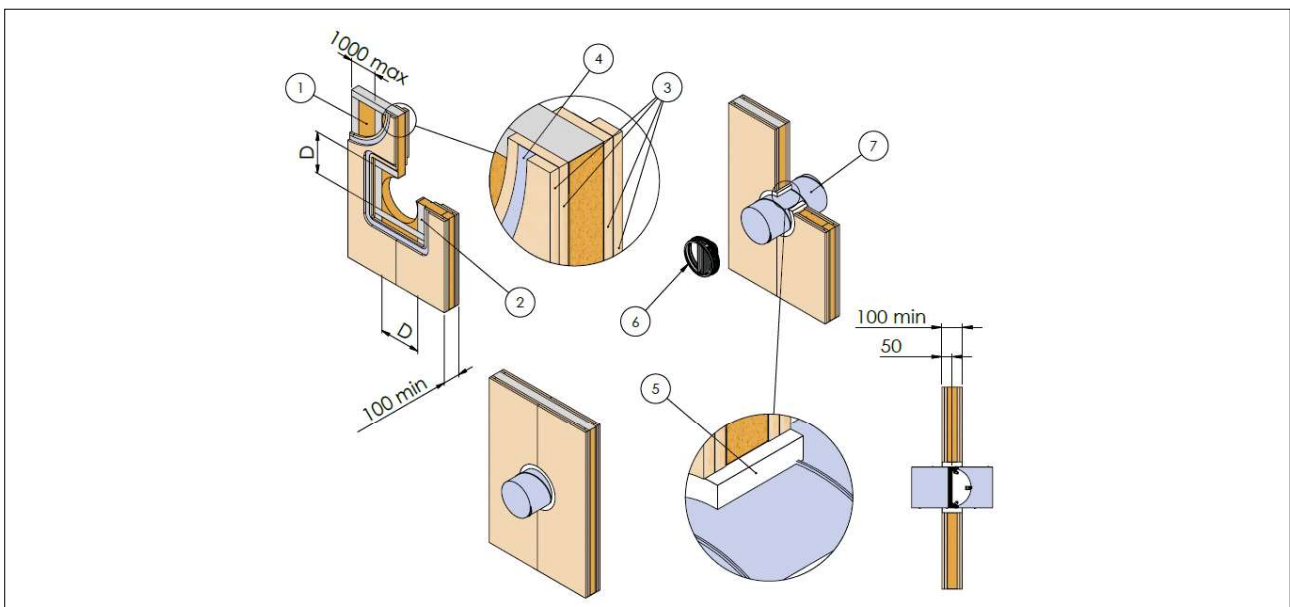

**Light safety wall, ducted one side, circular hole, mortar or plaster putty**

- |   |   |
|---|---|
| 1. Rock wool density up to 40 kg/m <sup>3</sup> (optional)                      | 5. Mortar or plaster putty                                    |
| 2. Metal frame  | 6. Terminal valve   |
| 3. plasterboard, thickness 12,5 mm type A: FBC1; type F: FBC4 and FBC7 (EN 520) | 7. Fire damper  |
| 4. Metal foil 0.5 mm thick  | 8. Ventilation duct   |
|   | D from nominal diameter min + 50 to nominal diameter max + 70 |

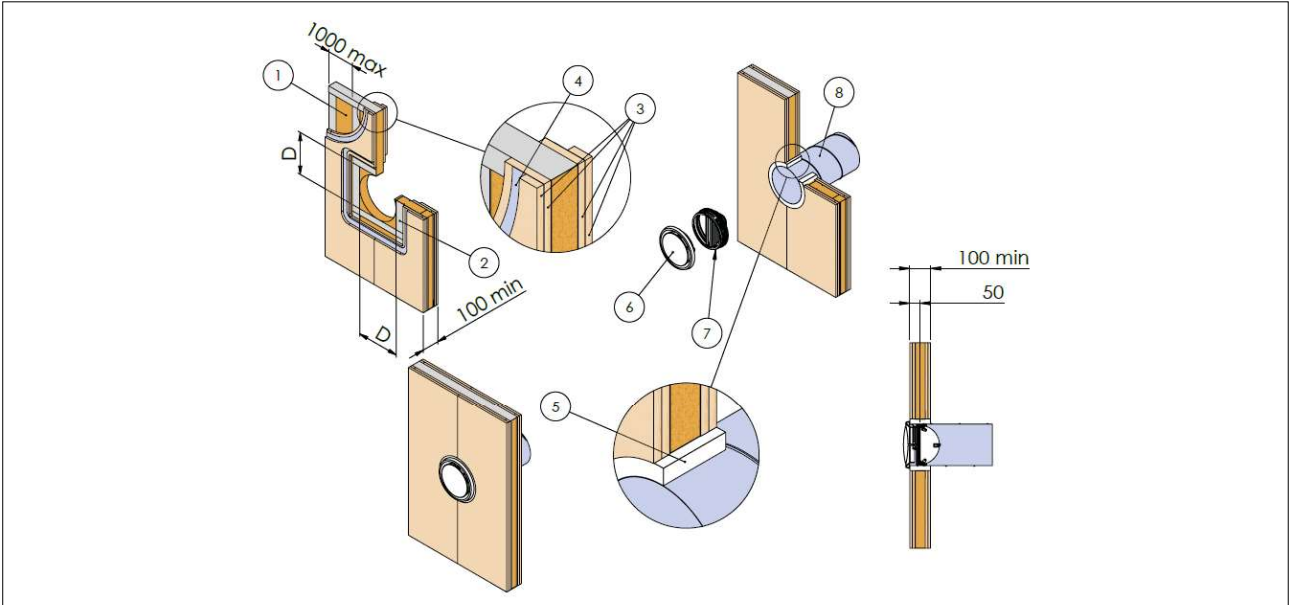

**Light security wall, transfer, round hole, mortar or plaster putty**

- |   |   |
|---|---|
| 1. Rock wool density up to 40 kg/m <sup>3</sup> (optional)                      | 5. Mortar or plaster putty                                    |
| 2. Metal frame  | 6. Terminal valve   |
| 3. plasterboard, thickness 12,5 mm type A: FBC1; type F: FBC4 and FBC7 (EN 520) | 7. Fire damper  |
| 4. Metal foil 0.5 mm thick  | 8. Ventilation duct   |
|   | D from nominal diameter min + 50 to nominal diameter max + 70 |

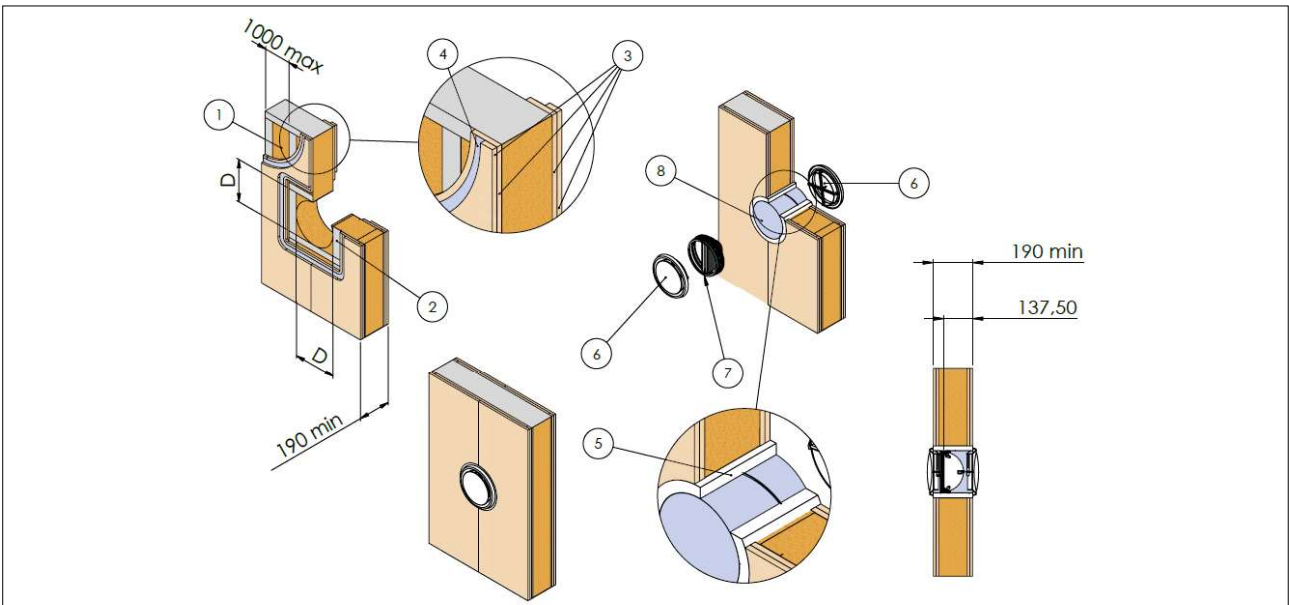

**Light safety wall, ducted both sides, circular hole, rock wool with mortar or plaster putty**

- |   |   |
|---|---|
| 1. Rock wool density up to 40 kg/m <sup>3</sup> (optional)                      | 5. Rock wool, 40 kg/m <sup>3</sup>                            |
| 2. Metal frame  | 6. Mortar or plaster putty                                    |
| 3. plasterboard, thickness 12,5 mm type A: FBC1; type F: FBC4 and FBC7 (EN 520) | 7. Fire damper  |
| 4. Foil thickness 0.5 mm  | 8. Ventilation duct   |
|   | D from nominal diameter min + 50 to nominal diameter max + 70 |

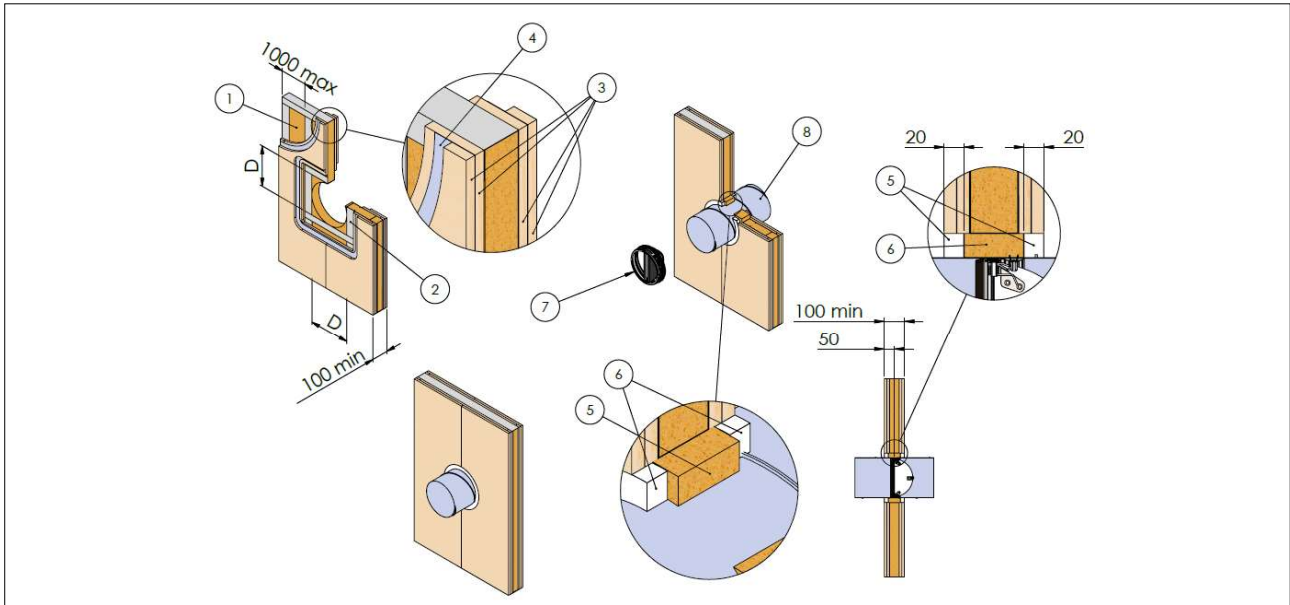

**Light safety wall, ducted one side, circular hole, rock wool with mortar or plaster putty**

- |   |   |
|---|---|
| 1. Rock wool density up to 40 kg/m <sup>3</sup> (optional)                      | 6. Rock wool, 40 kg/m <sup>3</sup>                            |
| 2. Metal frame  | 7. Terminal valve   |
| 3. plasterboard, thickness 12,5 mm type A: FBC1; type F: FBC4 and FBC7 (EN 520) | 8. Fire damper  |
| 4. Foil thickness 0.5 mm  | 9. Ventilation duct   |
| 5. Mortar or plaster putty  | D from nominal diameter min + 50 to nominal diameter max + 70 |

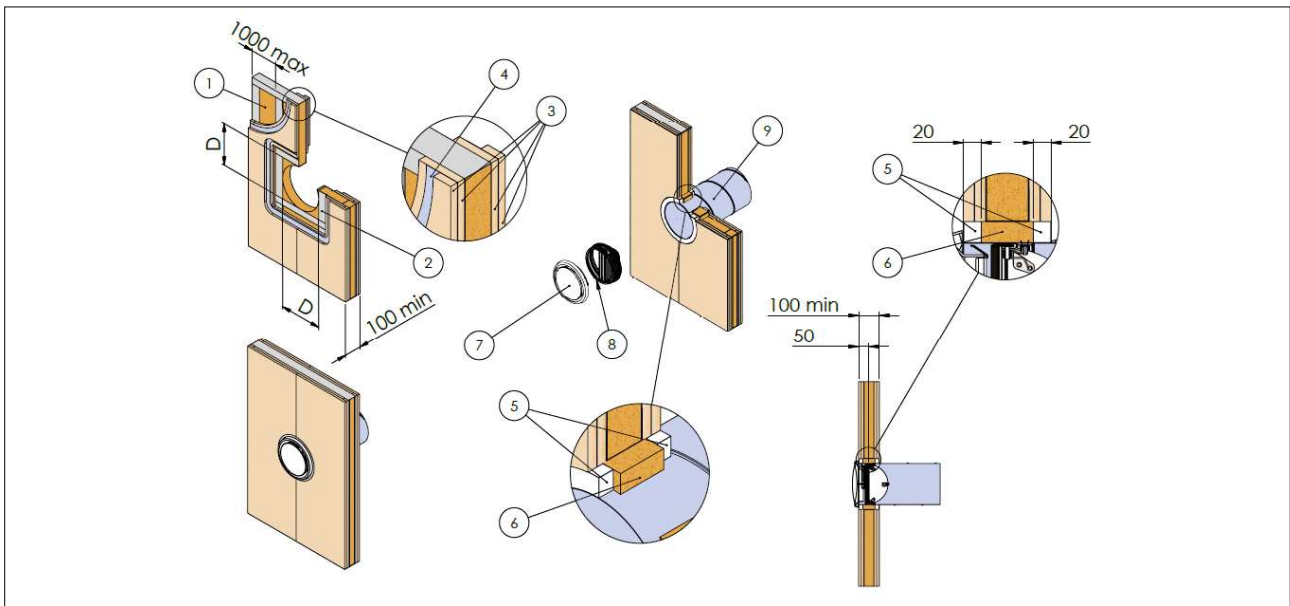



**Light safety wall, transfer, round hole, rock wool with mortar or plaster putty**

- |   |   |
|---|---|
| 1. Rock wool density up to 40 kg/m <sup>3</sup> (optional)                      | 6. Rock wool, 40 kg/m <sup>3</sup>                            |
| 2. Metal frame  | 7. Terminal valve   |
| 3. plasterboard, thickness 12,5 mm type A: FBC1; type F: FBC4 and FBC7 (EN 520) | 8. Fire damper  |
| 4. Foil thickness 0.5 mm  | 9. Ventilation duct   |
| 5. Mortar or plaster putty  | D from nominal diameter min + 50 to nominal diameter max + 70 |

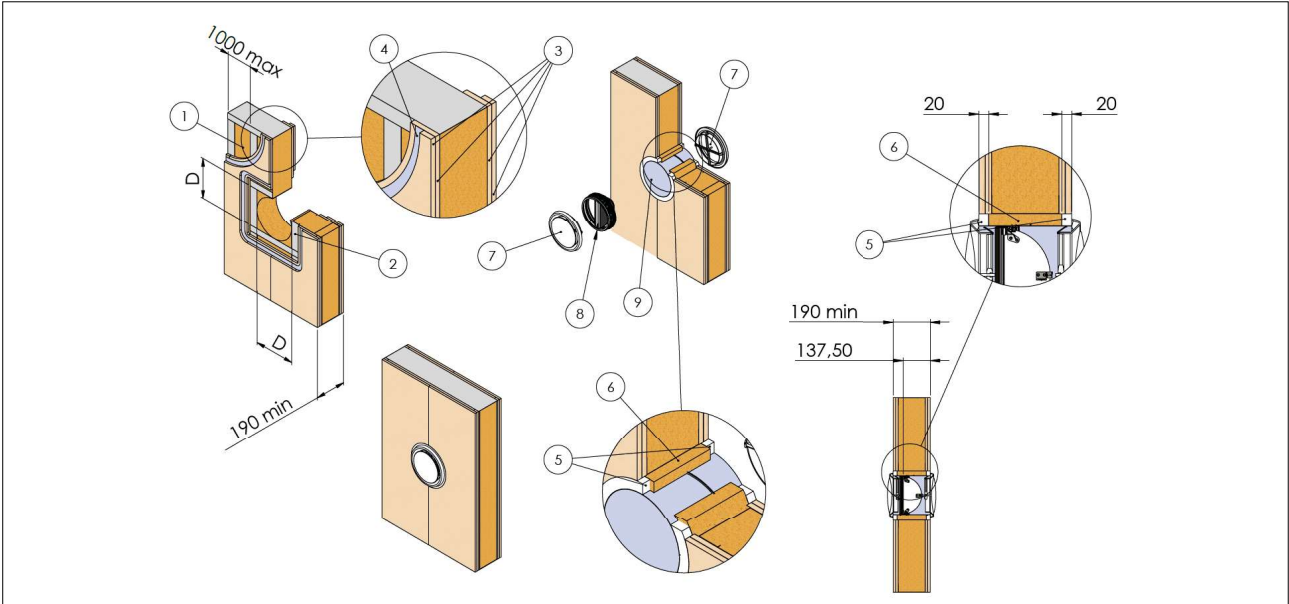

**Light safety wall, ducted both sides, circular hole, rock wool with plasterboard - EI60-S - FBC1**

- |   |   |
|---|---|
| 1. Rock wool density up to 40 kg/m <sup>3</sup> (optional)                      | 6. Fire damper  |
| 2. Metal frame  | 7. Ventilation duct   |
| 3. plasterboard, thickness 12,5 mm type A: FBC1; type F: FBC4 and FBC7 (EN 520) | 8. Plasterboard arch infill type A, thickness 12,5 mm or promactect 100 thickness 12 mm |
| 4. Foil thickness 0.5 mm  | 9. Self-drilling screw Ø 3,5 X 45 mm  |
| 5. Rock wool, 40 kg/m <sup>3</sup>  | D from nominal diameter min + 50 to nominal diameter max + 70                           |

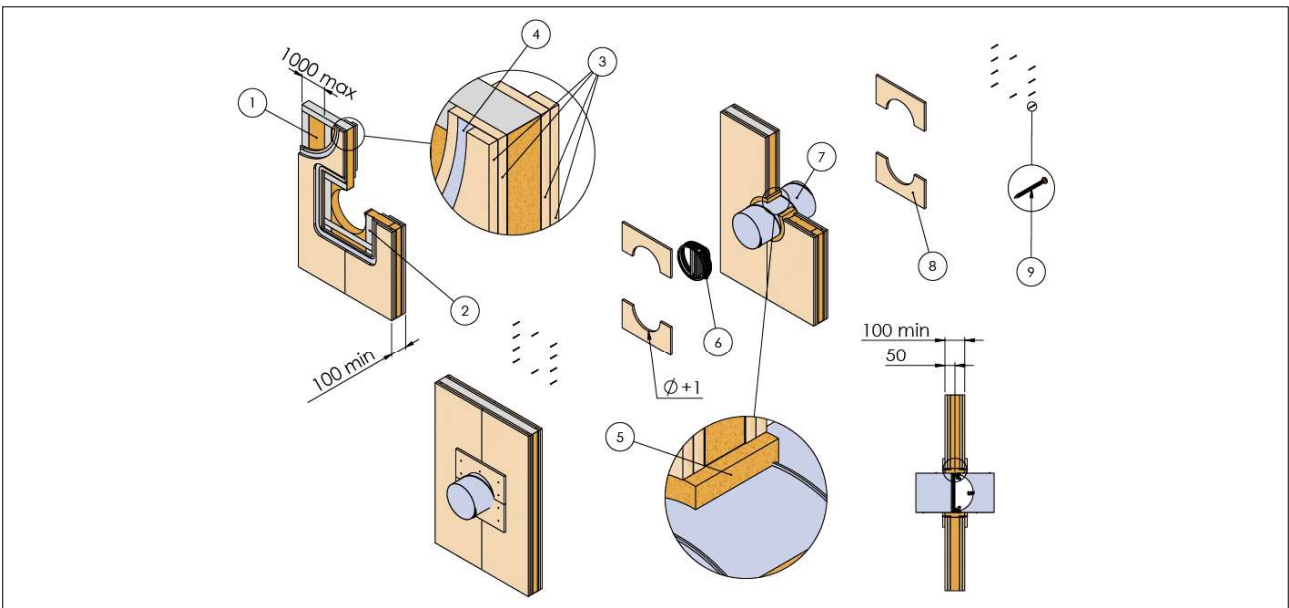

**Light wall, ducted both sides, square hole, rock wool with plasterboard - EI90-S - FBC4- EI120-S - FBC7**

- |   |   |
|---|---|
| 1. Rock wool density up to 40 kg/m <sup>3</sup> (optional)                      | 6. Fire damper  |
| 2. Metal frame  | 7. Ventilation duct   |
| 3. plasterboard, thickness 12,5 mm type A: FBC1; type F: FBC4 and FBC7 (EN 520) | 8. Plasterboards arch infill type F, thickness 12,5 mm or promatect 100 thickness 12 mm |
| 4. Foil thickness 0.5 mm  | 9. Self-drilling screw Ø 3,5 X 45 mm  |
| 5. Rock wool, 40 kg/m <sup>3</sup>  | D from nominal diameter min + 50 to nominal diameter max + 70                           |

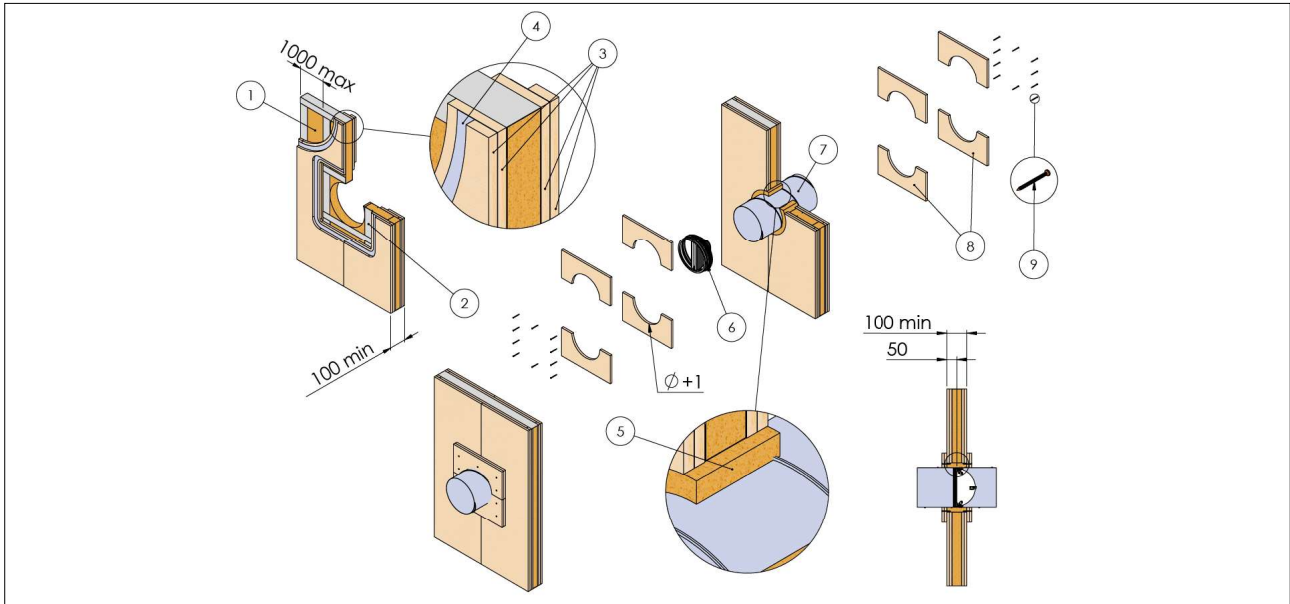

**Light safety wall, ducted one side, circular hole, rock wool with plasterboard**

- |   |   |
|---|---|
| 1. Rock wool density up to 40 kg/m <sup>3</sup> (optional)                      | 7. Fire damper  |
| 2. Metal frame  | 8. Ventilation duct   |
| 3. plasterboard, thickness 12,5 mm type A: FBC1; type F: FBC4 and FBC7 (EN 520) | 9. Plasterboard arch infill, thickness 12,5 mm or promatect 100 thickness 12 mm |
| 4. Foil thickness 0.5 mm  | 10. Self-drilling screw Ø 3,5 X 45 mm   |
| 5. Rock wool, 40 kg/m <sup>3</sup>  | D from nominal diameter min + 50 to nominal diameter max + 70                   |
| 6. Terminal valve   |   |

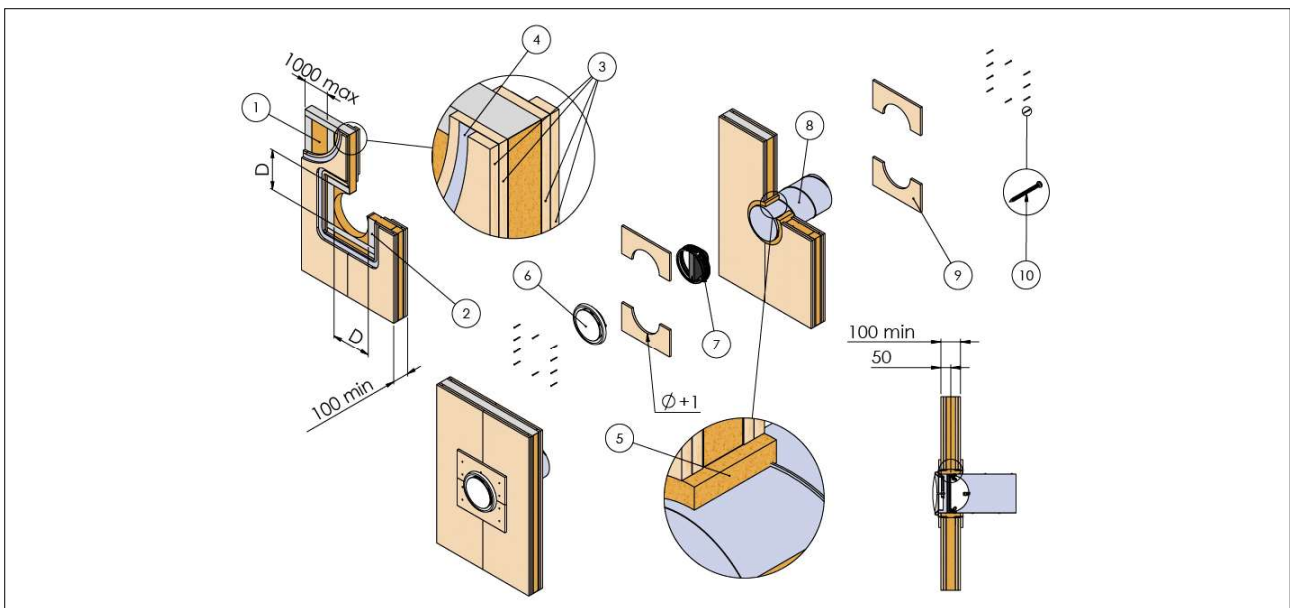



**Light safety wall, transfer, round hole, rock wool with plasterboard**

- |   |   |
|---|---|
| 1. Rock wool density up to 40 kg/m <sup>3</sup> (optional)                      | 7. Fire damper  |
| 2. Metal frame  | 8. Ventilation duct   |
| 3. plasterboard, thickness 12,5 mm type A: FBC1; type F: FBC4 and FBC7 (EN 520) | 9. Plasterboard arch infill, thickness 12,5 mm or promatect 100 thickness 12 mm |
| 4. Foil thickness 0.5 mm  | 10. Self-drilling screw $\varnothing$ 3,5 X 45 mm                               |
| 5. Rock wool, 40 kg/m <sup>3</sup>  | D from nominal diameter min + 50 to nominal diameter max + 70                   |
| 6. Terminal valve   |   |

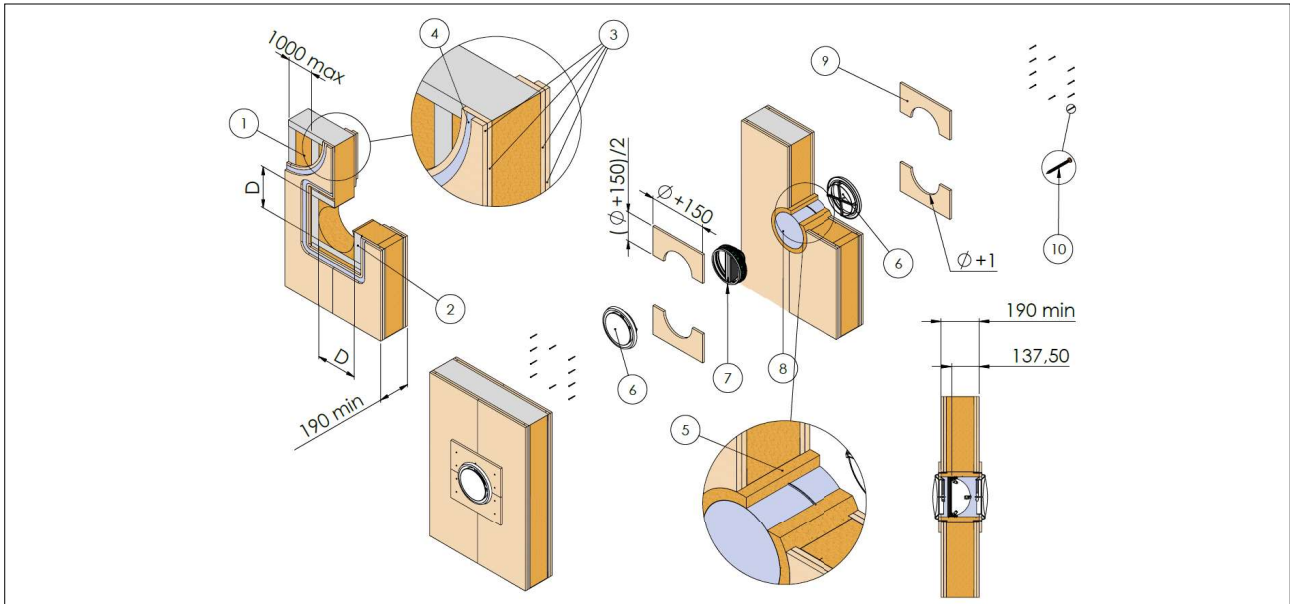

### 3.11. Installations within floor

See section Construction supports characteristics for more details, observe the minimum distances indicated in section Minimum distances, carry out a functional test before and after installation. See section for more details.

#### 3.11.1. Floor opening

A opening must be provided in the floor as indicated in the drawing.

#### 3.11.2. Damper positioning

Install the fire damper in the ventilation duct as shown in the drawing. Close the blade before installing the fire damper

#### 3.11.3. Filling

Fill the space between ventilation duct and wall as indicated in the drawing.

#### 3.11.4. Insulation

The floor must have a fire resistance class greater than or equal to that of the damper

**Floor, ducted both sides, square hole mortar or plaster filler**

- |    |  |   |                             |
|----|--|---|-----------------------------|
| 1. | Mortar or plaster putty                                    | S | = min 100 mm for FBC1       |
| 2. | Floor  |   | = min 150 mm for FBC4, FBC7 |
| 3. | Fire damper  | L | = 50 mm for FBC1            |
| 4. | Ventilation duct   |   | = 75 mm for FBC4, FBC7      |
| D  | From nominal diameter min + 0 to nominal diameter max + 70 |   |                             |

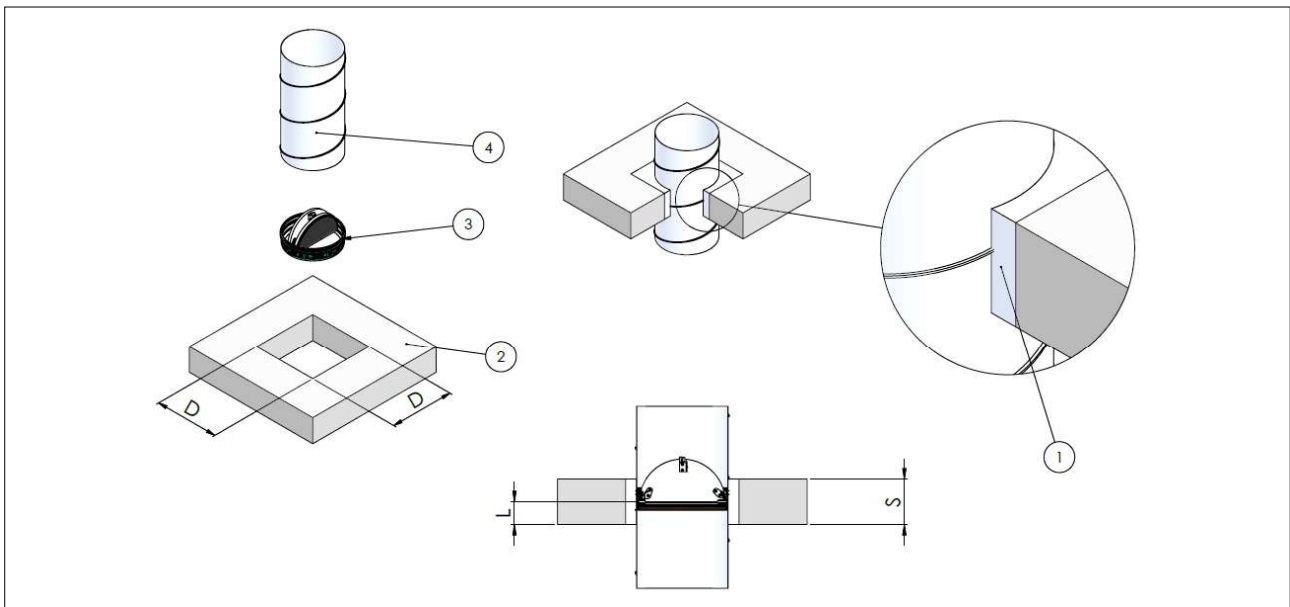

**Floor, channelled one side, square hole mortar or plaster filler**

1. Mortar or plaster putty
2. Terminal valve
3. Floor
4. Fire damper
5. Ventilation duct

- D From nominal diameter min + 0 to nominal diameter max + 70  
 S = min 100 mm for FBC1  
 = min 150 mm for FBC4, FBC7  
 L = 50 mm for FBC1  
 = 75 mm for FBC4, FBC7

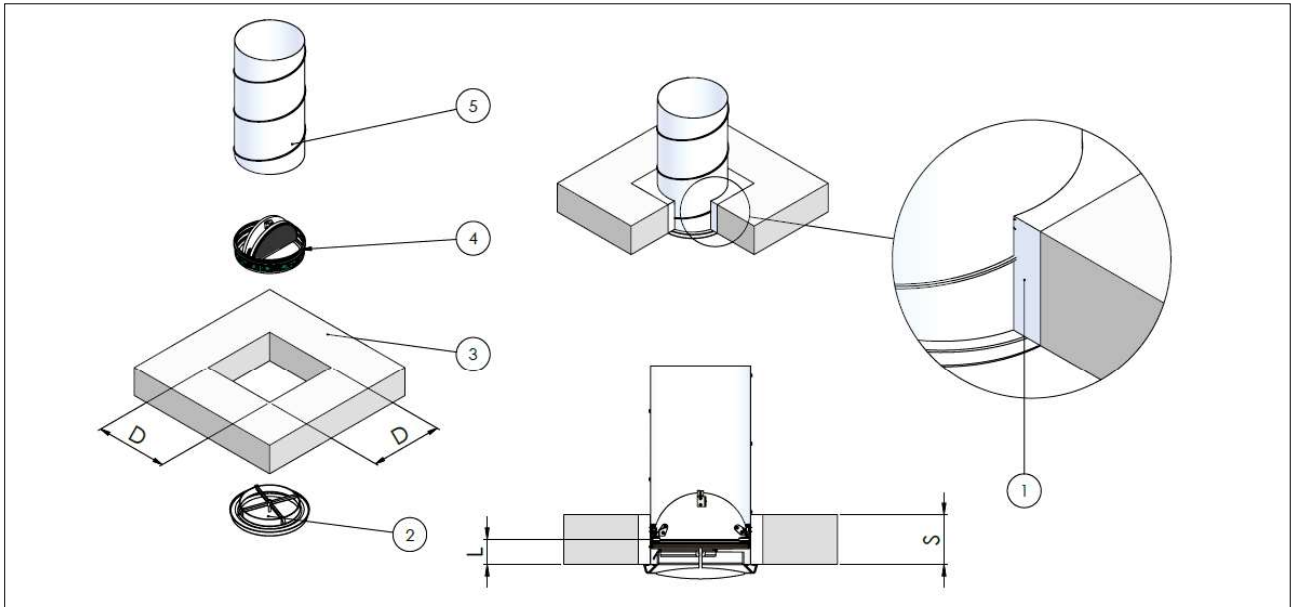

**Floor, transfer, square hole mortar or plaster putty**

1. Mortar or plaster putty
2. Terminal valve
3. Floor
4. Fire damper

5. Ventilation duct  
 D From nominal diameter min + 0 to nominal diameter max + 70  
 S = min 275 mm  
 L = 137,50 mm

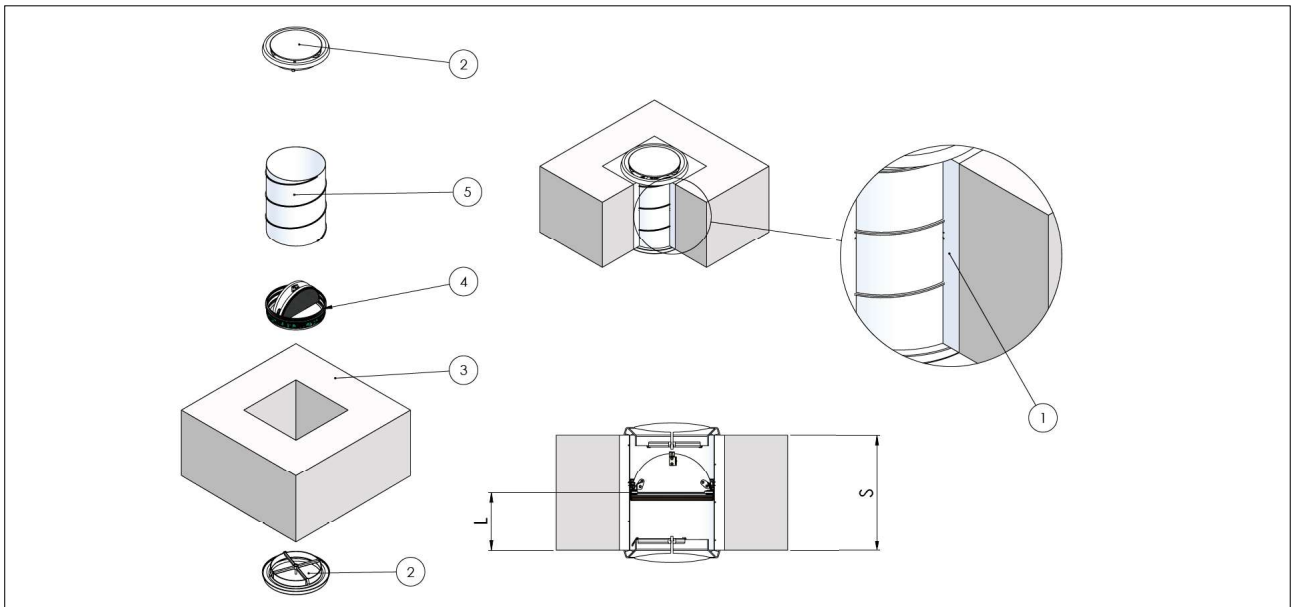

**floor, ducted both sides, circular hole mortar or plaster filler**

1. Mortar or plaster putty
  2. Floor
  3. Fire damper
  4. Ventilation duct
- D From nominal diameter min + 0 to nominal diameter max + 70

- S = min 100 mm for FBC1  
 = min 150 mm for FBC4, FBC7
- L = 50 mm for FBC1  
 = 75 mm for FBC4, FBC7

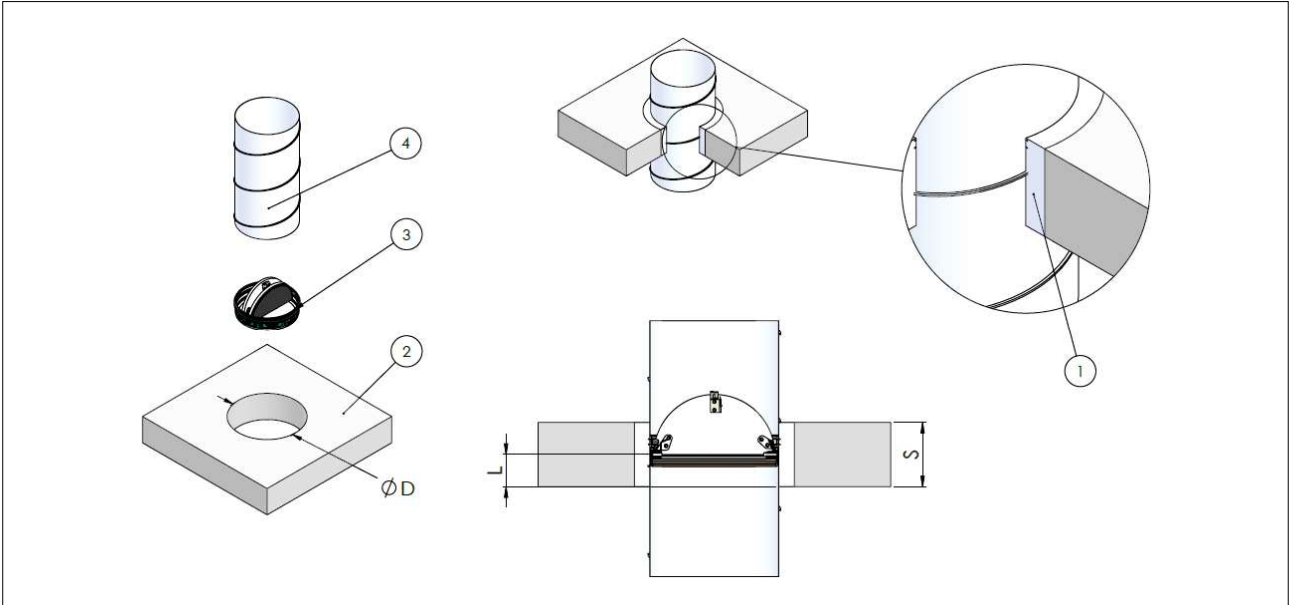

**floor, ducted one side, circular hole mortar or plaster filler**

1. Mortar or plaster putty
  2. Terminal valve
  3. Floor
  4. Fire damper
  5. Ventilation duct
- D From nominal diameter min + 0 to nominal diameter max + 70

- S = min 100 mm for FBC1  
 = min 150 mm for FBC4, FBC7
- L = 50 mm for FBC1  
 = 75 mm for FBC4, FBC7

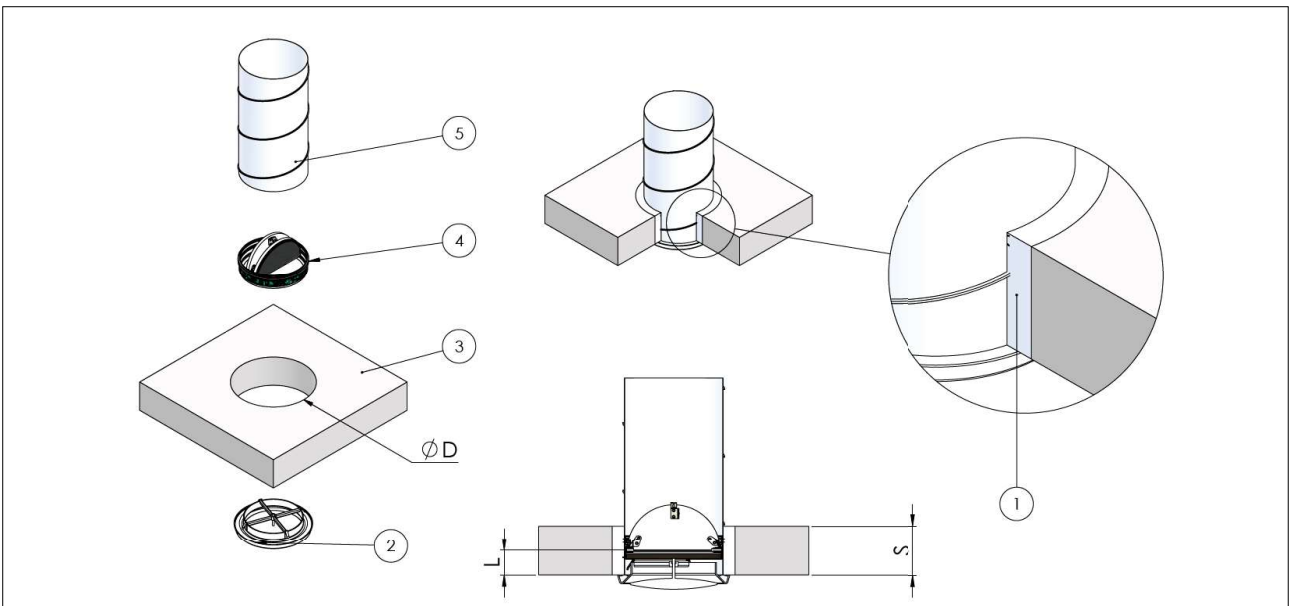

**Floor, transfer, circular hole mortar or plaster putty**

- 1. Mortar or plaster putty
- 2. Terminal valve
- 3. Floor
- 4. Fire damper

- 5. Ventilation duct
- D From nominal diameter min + 0 to nominal diameter max + 70
- S = min 275 mm
- L = 137,50 mm

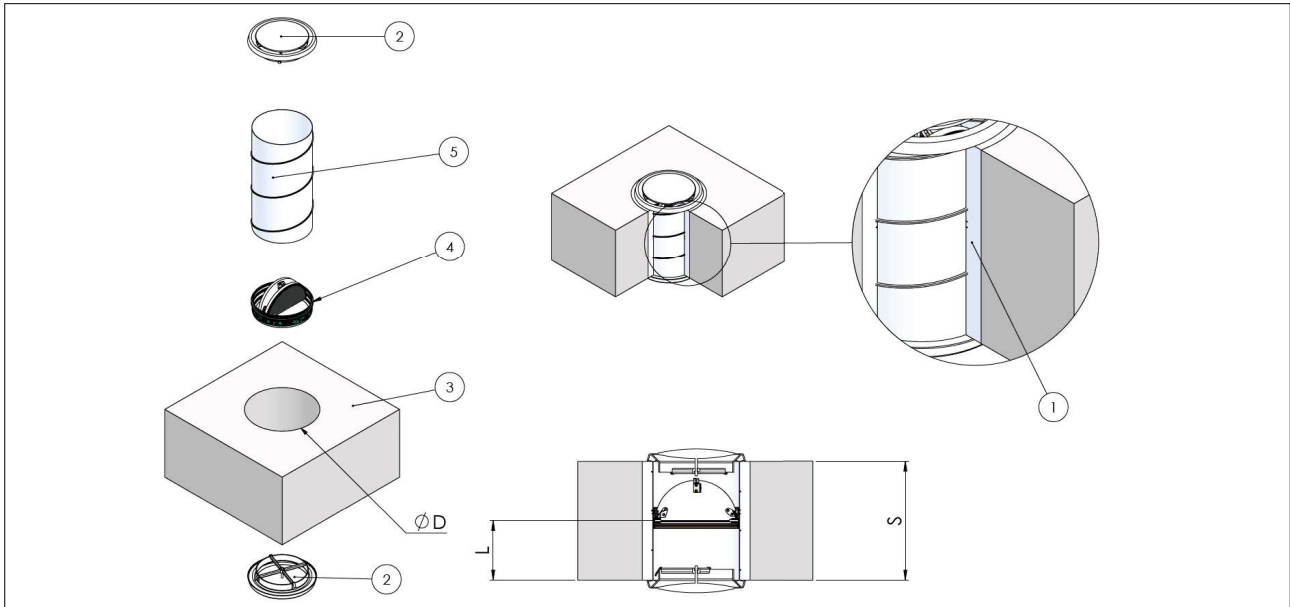

### 3.12. Installations within vertical wall with Fire Batt (Weichschott) sealing

See section Construction supports characteristics for more details, observe the minimum distances indicated in section Minimum distances, carry out a functional test before and after installation. See section for more details.

#### 3.12.1. Wall opening

A opening must be provided in the wall as indicated in the drawing.

#### 3.12.2. Damper positioning

Install the fire damper in the ventilation duct as shown in the drawing. Close the blade before installing the fire damper

#### 3.12.3. Filling

Fill the space between the damper and the wall using Fire Batt (Weichschott) sealing made from two rock wool panels with minimum thickness of 50 mm and minimum density of 140 kg/m<sup>3</sup>.

The panels must be covered on both faces of the wall with endothermic varnish type PROMASTOP E PASTE or HILTI CFS-CT (minimum thickness of 1 mm) and with an internal perimeter sealant type PROMASTOP E PASTE or HILTI CFS-S ACR (minimum thickness of 1 mm).

#### 3.12.4. Insulation

The wall must be of the same or higher strength class than the damper.

#### Weichschott wall, ducted on both sides

- |  |  |
|--|--|
| 1. Rock wool panel 50 mm thick with 140 kg/m <sup>3</sup> density. | 5. Fire damper   |
| 2. PROMASTOP E PASTE or HILTI CFS-S ACR type sealant               | 6. Vertical rigid wall density $\geq 550$ kg/m <sup>3</sup> or vertical light wall (plasterboard) type A (FBC1) ; type F: FBC4 and FBC7 (EN 520) |
| 3. PROMASTOP E PASTE or HILTI CFS-CT endothermic varnish           | D nominal diameter + 600 max   |
| 4. Ventilation duct  |  |

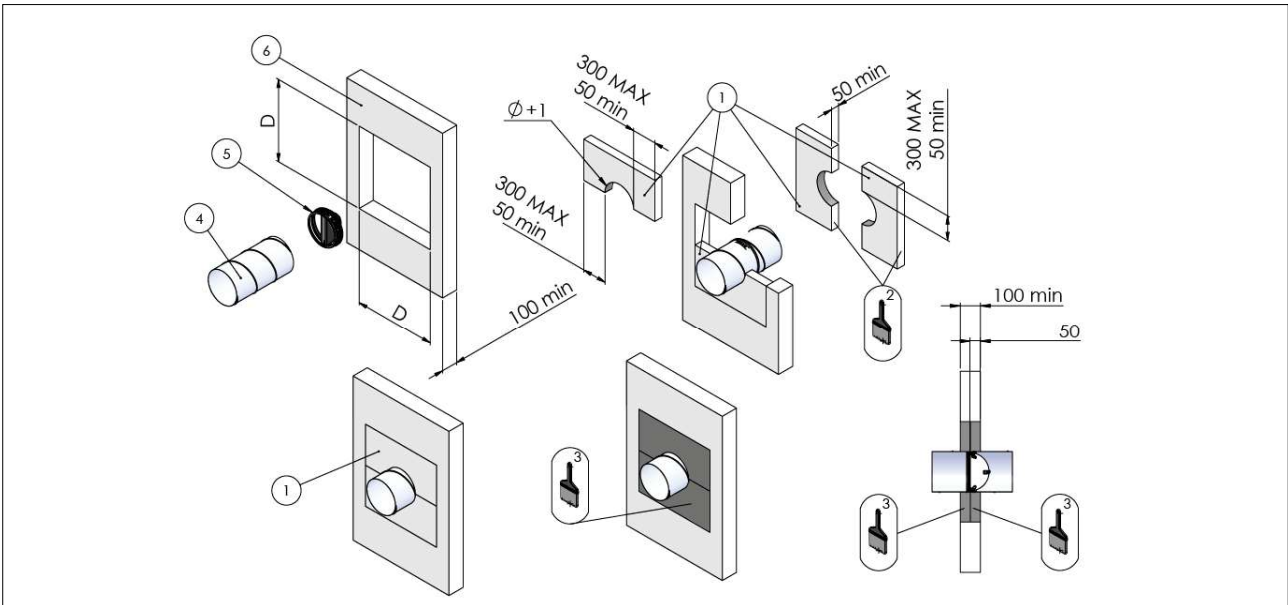

**Weichschott wall, ducted one side**

- |  |  |
|--|--|
| 1. Rock wool panel 50 mm thick with 140 kg/m <sup>3</sup> density. | 6. Fire damper   |
| 2. PROMASTOP E PASTE or HILTI CFS-S ACR type sealant               | 7. Vertical rigid wall density ≥550 kg/m <sup>3</sup> or vertical light wall (plasterboard) type A (FBC1) ; type F: FBC4 and FBC7 (EN 520) |
| 3. PROMASTOP E PASTE or HILTI CFS-CT endothermic varnish           | D nominal diameter + 600 max   |
| 4. Terminal valve  |  |
| 5. Ventilation duct  |  |

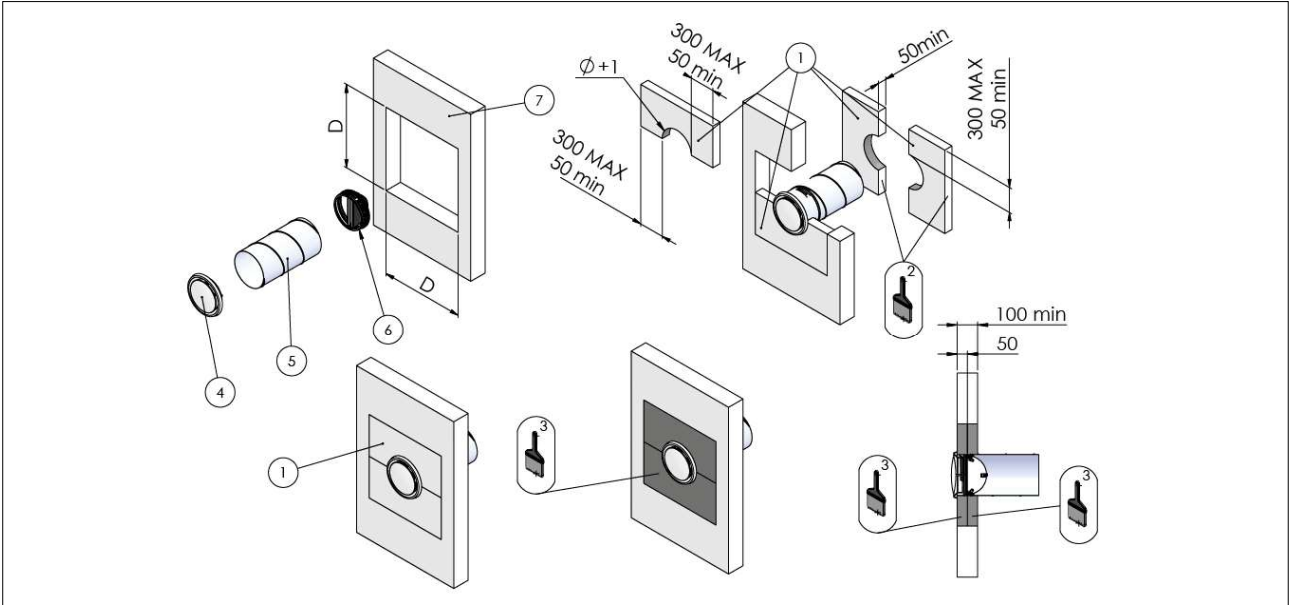

**weichschott wall, transfer**

- |   |  |
|---|--|
| 1. Rock wool panel with thickness 137.50 mm and density 140 kg/m <sup>3</sup> | 6. Fire damper   |
| 2. PROMASTOP E PASTE or HILTI CFS-S ACR type sealant                          | 7. Vertical rigid wall density ≥550 kg/m <sup>3</sup> or vertical light wall (plasterboard) type A (FBC1) ; type F: FBC4 and FBC7 (EN 520) |
| 3. PROMASTOP E PASTE or HILTI CFS-CT endothermic varnish                      | D nominal diameter + 600 max   |
| 4. Terminal valve   |  |
| 5. Ventilation duct   |  |

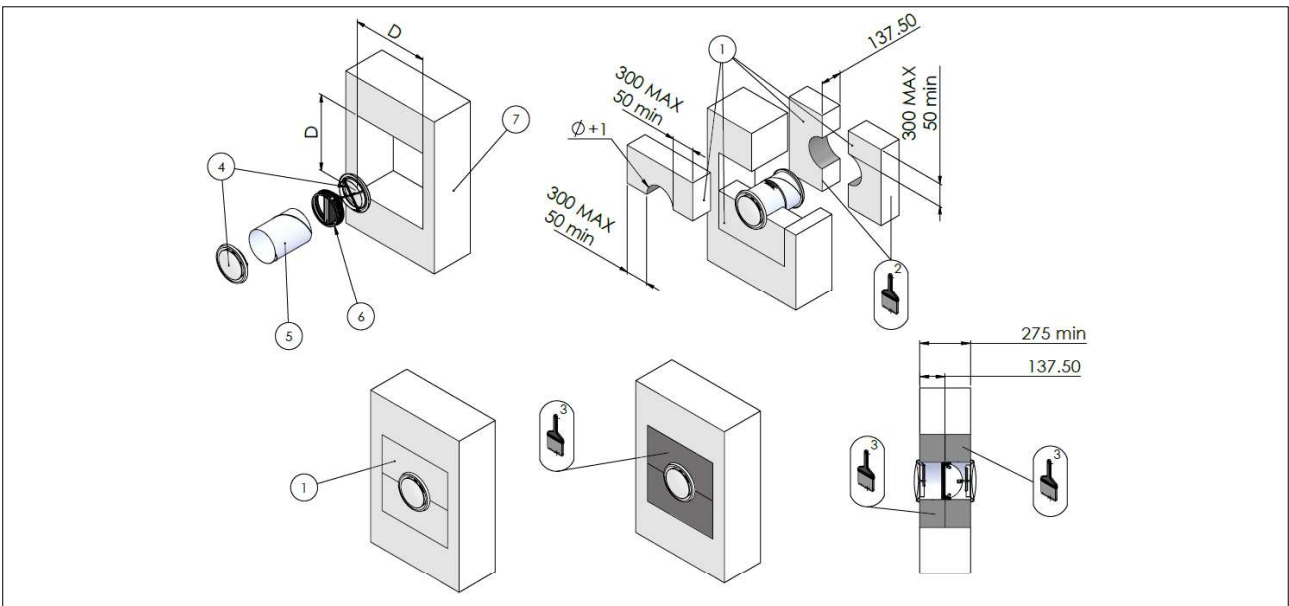



### 3.13. Installation within floor with Fire Batt (Weichschott) sealing

See section Construction supports characteristics for more details, observe the minimum distances indicated in section Minimum distances, carry out a functional test before and after installation. See section for more details.

#### 3.13.1. Floor opening

A opening must be provided in the floor as indicated in the drawing.

#### 3.13.2. Damper positioning

Position the damper in the opening so that the side of the closing mechanism extends as indicated in the drawing. The mechanism can be located both above and below the floor. Close the blade before installing the fire damper. Close the blade before installing the fire damper.

#### 3.13.3. Filling

Fill the space between the damper and the floor using Fire Batt (Weichschott) sealing made from two rock wool panels with minimum thickness of 50 mm and minimum density of 140 kg/m<sup>3</sup>.

The panels must be covered on both faces of the wall with endothermic varnish type PROMASTOP E PASTE or HILTI CFS-CT (minimum thickness of 1 mm) and with an internal perimeter sealant type PROMASTOP E PASTE or HILTI CFS-S ACR (minimum thickness of 1 mm).

#### 3.13.4. Insulation

The floor must have a fire resistance class greater than or equal to that of the damper

#### Weichschott floor, ducted on both sides

- |    |   |   |                             |
|----|---|---|-----------------------------|
| 1. | Rock wool panel 50 mm thick with 140 kg/m <sup>3</sup> density. | D | Nominal diameter + 600 max  |
| 2. | PROMASTOP E PASTE or HILTI CFS-S ACR type sealant               | S | = min 100 mm for FBC1       |
| 3. | PROMASTOP E PASTE or HILTI CFS-CT endothermic varnish           |   | = min 150 mm for FBC4, FBC7 |
| 4. | Floor   | L | = 50 mm for FBC1            |
| 5. | Fire damper   |   | = 75 mm for FBC4, FBC7      |
| 6. | Ventilation duct  |   |                             |

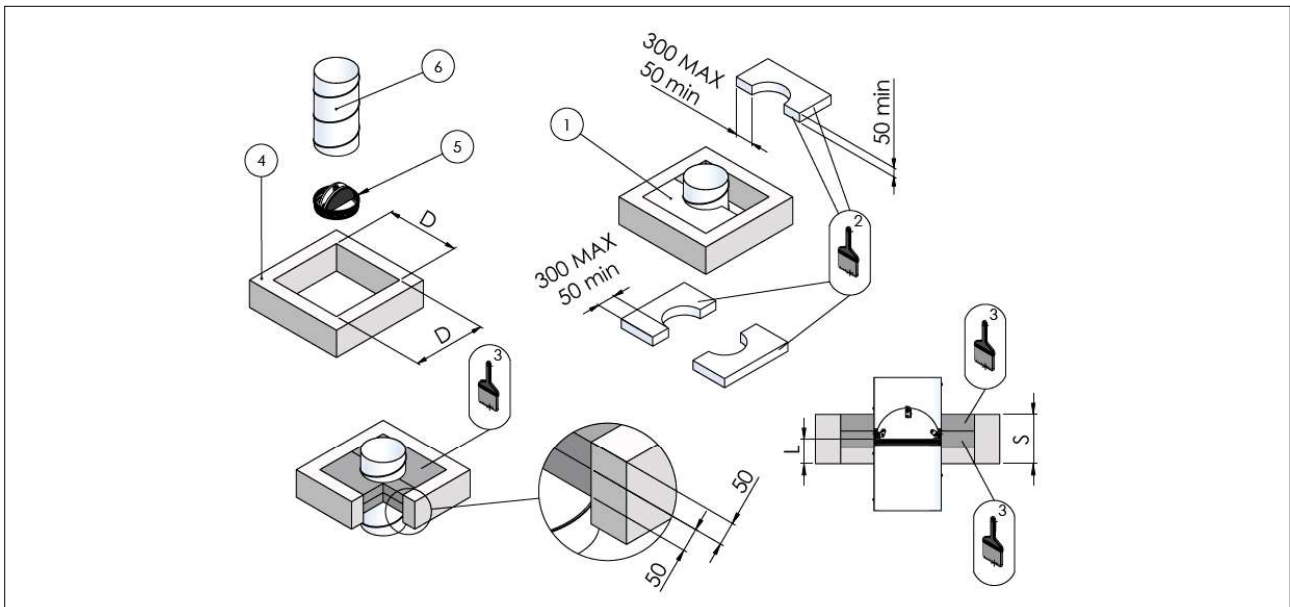

**Weichschott floor, ducted one side**

- |  |                              |
|--|------------------------------|
| 1. Rock wool panel 50 mm thick with 140 kg/m <sup>3</sup> density. | 7. Ventilation duct          |
| 2. PROMASTOP E PASTE or HILTI CFS-S ACR type sealant               | D Nominal diameter + 600 max |
| 3. PROMASTOP E PASTE or HILTI CFS-CT endothermic varnish           | S = min 100 mm for FBC1      |
| 4. Terminal valve  | = min 150 mm for FBC4, FBC7  |
| 5. Floor   | L = 50 mm for FBC1           |
| 6. Fire damper   | = 75 mm for FBC4, FBC7       |

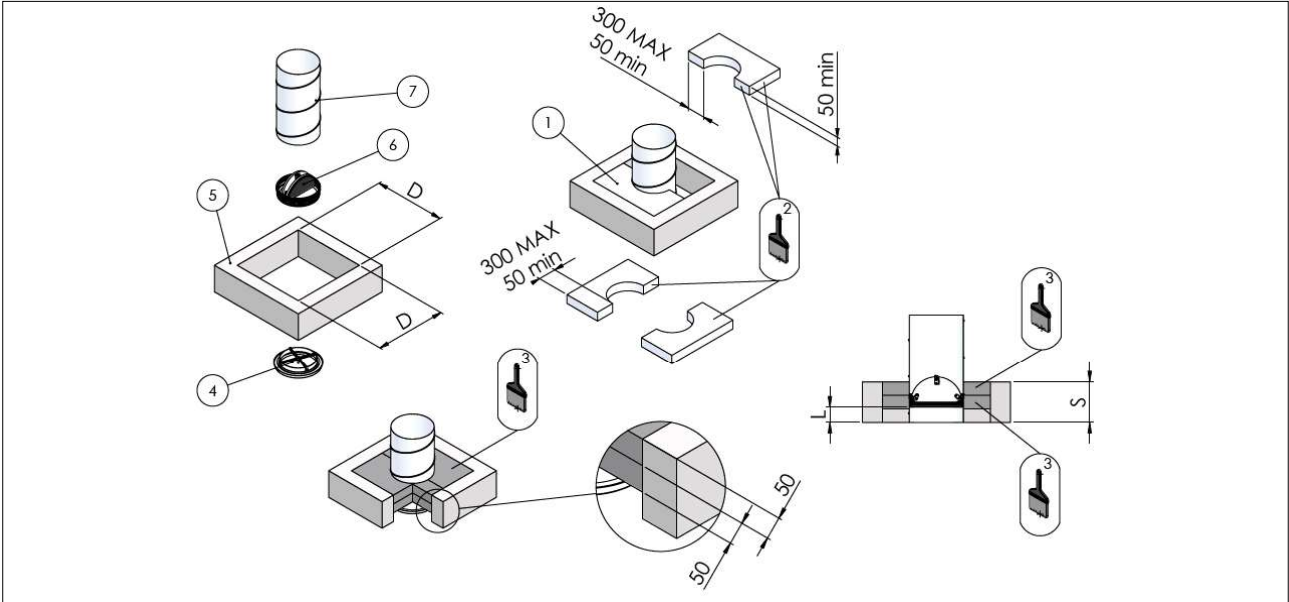

**Weichschott Floor, transfer**

- |   |                              |
|---|------------------------------|
| 1. Rock wool panel with thickness 137.50 mm and density 140 kg/m <sup>3</sup> | 6. Fire damper               |
| 2. PROMASTOP E PASTE or HILTI CFS-S ACR type sealant                          | 7. Ventilation duct          |
| 3. PROMASTOP E PASTE or HILTI CFS-CT endothermic varnish                      | D Nominal diameter + 600 max |
| 4. Terminal valve   | S = min 275 mm               |
| 5. Floor  | L = 137,50 mm                |

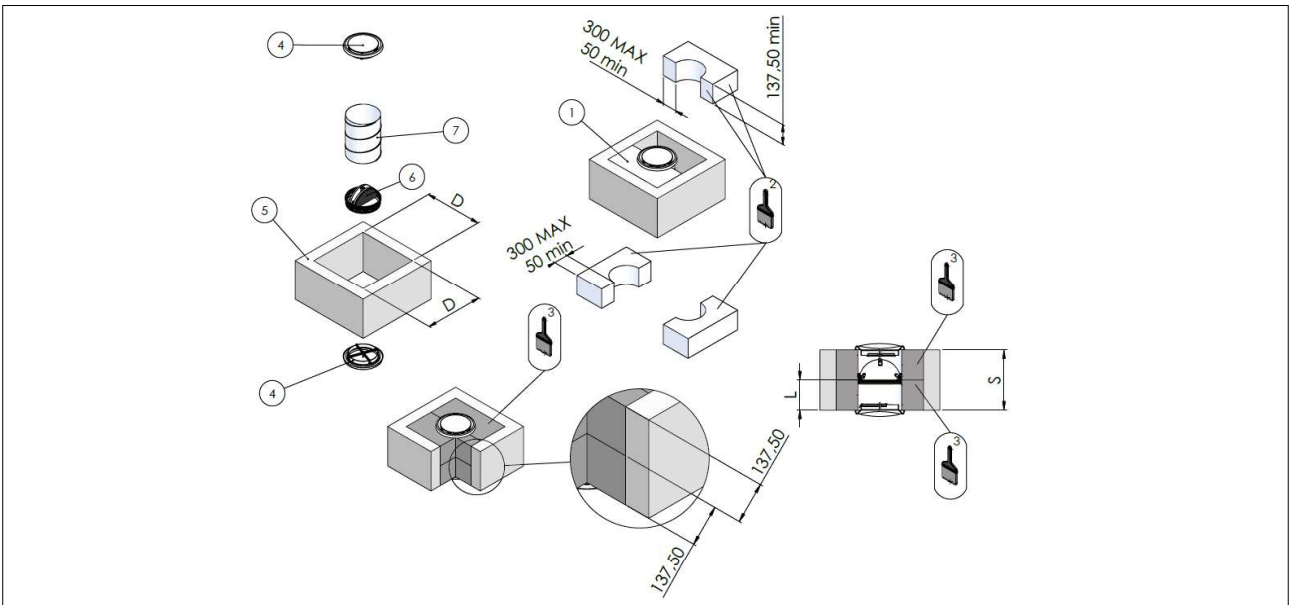

## 4. ELECTRICAL CONNECTIONS

### 4.1. Electrical wiring

Electrical connections must be done by qualified and trained people.

Switch off the power supply before starting any work on the electric elements. Never switch on the power supply during electrical connections.

#### 4.1.1. Wiring diagram for position microswitches

##### FCU: Closed damper contact

- A The fire damper's blade is open (the air flow is allowed)
- B The fire damper's blade is closed (the air flow is not allowed)
- 4 Normally opened (BLUE)
- 1 Common/neutral (BLACK)
- 2 Normally closed (GREY)

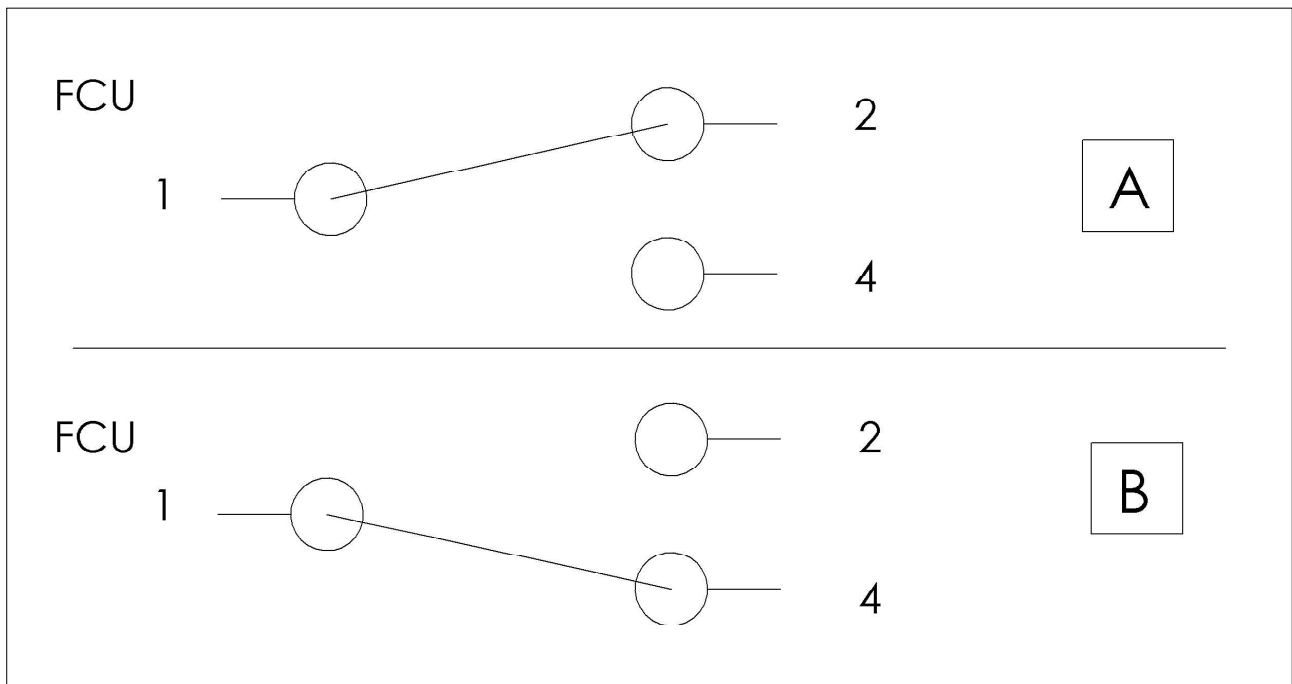

min. supply: 4 V AC - 1 mA  
max. supply: 250 V AC - 10 A

## 5. MAINTENANCE AND INSPECTIONS

Fire dampers and control mechanisms do not require routine maintenance.

Extraordinary maintenance (repairs) and periodic inspection operations are the responsibility of the ventilation system operator.

It is recommended to provide inspection hatches on both sides of the ducts connected to the fire damper.

The implementation of a periodic inspection plan allows to guarantee the efficiency and functionality of the fire dampers for the fire safety of the building.

### 5.1. Periodic inspection and cleaning

Periodic inspection shall be performed in accordance with the requirements of the law or by the building regulations or other local regulations.

In the absence of specific regulations (or to their complement), in accordance with point 8.3 of the EN 1560 standard, it is recommended to carry out the following control activities at intervals of no more than 12 months:

- Check the servomotor electrical wiring for damage (where applicable);
- Check end-switch wiring for damage (where applicable);
- Check damper cleanliness and clean where necessary;
- Check the condition of blades and seals, rectify and report where necessary;
- Check the correct opening and closing of the fire damper by manual operation according to the instructions in the technical manual of the fire damper;
- Check the opening and closing operation of the damper controlled by the fire alarm system (if present);
- Check the operation of the end switches in open and closed state, adjust and report if necessary (if it is present);
- Confirm that the damper fulfils its function as part of the control system (where necessary);
- Check that the damper is left in its normal operating position, which usually corresponds to the open position.

### 5.2. Repair

For safety reasons, repair activities involving fire-fighting components must be carried out **only** by qualified personnel.

Only original spare parts supplied by the fire damper manufacturer may be used. (see section Accessories and spare parts [p.72](#))

A functional test must be performed after each repair.

At the end of the inspection, cleaning or repair operations, check that the fire damper is in the normal operating position.

Keep records of all inspections, repair activities, any problems encountered and their resolution.

This practice, even when not mandatory, is very useful in practice.

### 5.3. Disposal

Disposal in case of destruction must be carried out in accordance with national legislation. For electrical and electronic parts also refer to EU Directive 2011/65.

## 6. SELECTION

### 6.1. Air flow rates in relation to the diameter

$\emptyset$	Front section	Net section	Maximum air flow	Maximum speed
mm	m <sup>2</sup>	m <sup>2</sup>	m <sup>3</sup> /h	m/s
100	0,008	0,002	179	6
125	0,012	0,004	346	8
160	0,020	0,010	652	9
200	0,031	0,017	1216	11

### 6.2. Air flow rates as a function of the pressure drop

$\emptyset$	$\Delta P$ 20 Pa		$\Delta P$ 30 Pa		$\Delta P$ 40 Pa	
	Q	Lw	Q	Lw	Q	Lw
mm	m <sup>3</sup> /h	dB(A)	m <sup>3</sup> /h	dB(A)	m <sup>3</sup> /h	dB(A)
100	78	34,6	96	39,7	112	43,5
125	160	37,6	196	42,2	226	45,4
160	357	39,5	437	44,7	504	48,4
200	756	43,7	922	48,4	1061	51,8

### 6.3. Air flow rates as a function of generated sound levels

$\emptyset$	Lw 30 dB(A)		Lw 35 dB(A)		Lw 40 dB(A)	
	Q	$\Delta P$	Q	$\Delta P$	Q	$\Delta P$
mm	m <sup>3</sup> /h	Pa	m <sup>3</sup> /h	Pa	m <sup>3</sup> /h	Pa
100	65	14,1	79	20,5	97	30,3
125	114	10,2	143	16,0	178	24,9
160	246	9,4	299	14,0	364	20,8
200	423	6,1	523	9,4	645	14,5

6.4. Pressure drop and sound level graph

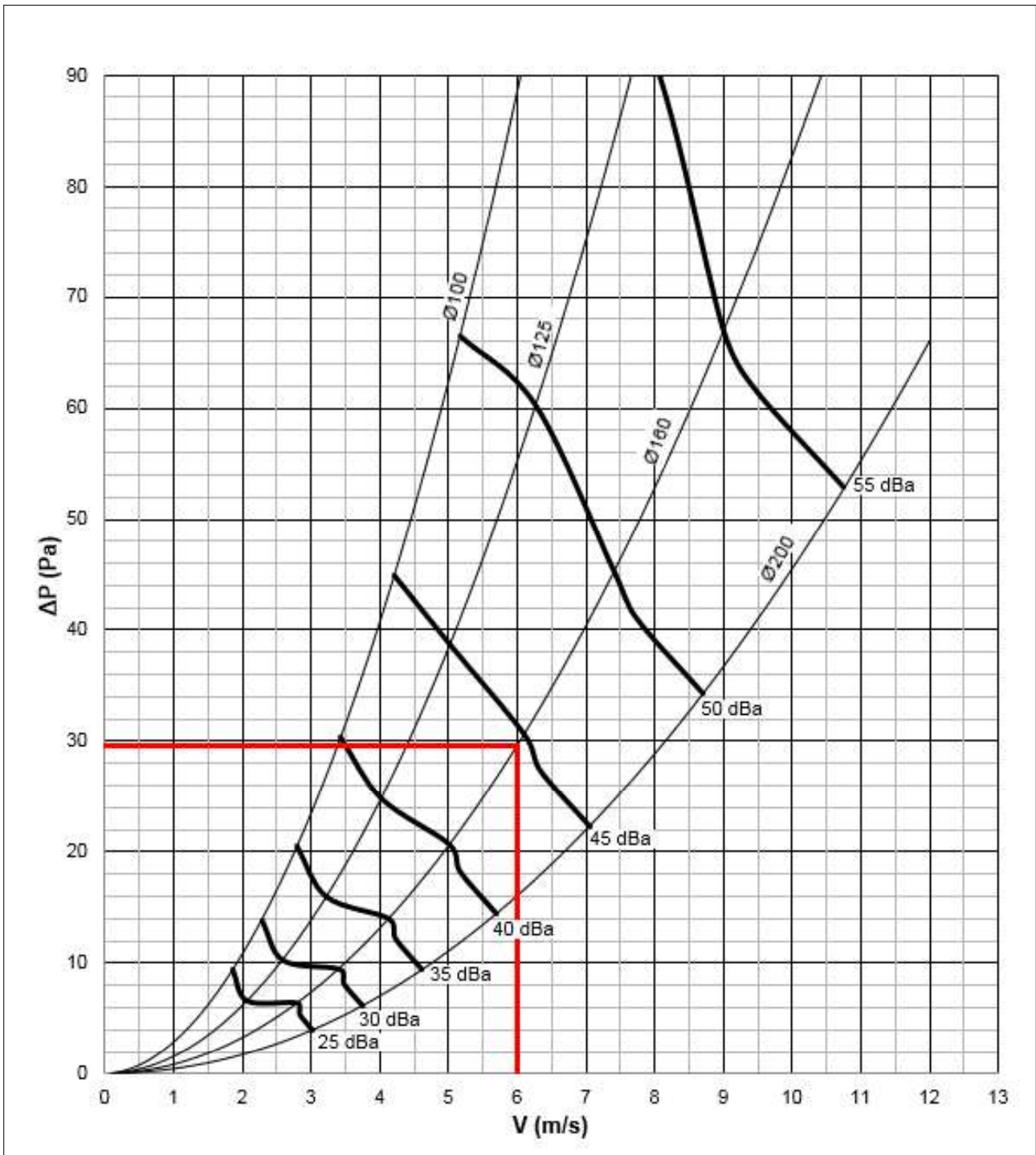

Ø	Lw 30 dB(A)		Lw 35 dB(A)		Lw 40 dB(A)	
	Q	ΔP	Q	ΔP	Q	ΔP
mm	m <sup>3</sup> /h	Pa	m <sup>3</sup> /h	Pa	m <sup>3</sup> /h	Pa
100	65	14,1	79	20,5	97	30,3
125	114	10,2	143	16,0	178	24,9
160	246	9,4	299	14,0	364	20,8
200	423	6,1	523	9,4	645	14,5

## 6.5. Sound spectrum table

Correction used to estimate the octave band spectrum (Values to be added to the noise levels in dB(A))

### Ø100

Hz	Speed (m/s)					
	2	4	6	8	10	12
63	9,3	3,9	-0,8	-4,8	-8,1	-10,7
125	3,3	-4	-9,7	-13,7	-16	-16,8
250	0	-2,5	-5,1	-7,8	-10,5	-13,3
500	-3,6	-3,4	-3,6	-4,1	-4,9	-6,1
1000	-7,3	-6,7	-6,3	-6,1	-6	-6
2000	-12,4	-8,7	-6,3	-5,4	-5,8	-7,6
4000	-9,9	-9,5	-9	-8,4	-7,7	-7
8000	-7,1	-11,1	-13	-12,9	-10,8	-6,7

### Ø125

Hz	Speed (m/s)					
	2	4	6	8	10	12
63	6,2	3,5	0,7	-2,2	-5,1	-8
125	1	-1,6	-4	-6,4	-8,6	-10,7
250	-1,6	-1,8	-2,5	-3,6	-5,1	-7,1
500	-6,9	-5,2	-4,4	-4,6	-5,6	-7,6
1000	-8,3	-7,3	-6,7	-6,6	-7	-7,8
2000	-11,4	-8,1	-6,1	-5,3	-5,8	-7,5
4000	-8,9	-9	-8,8	-8,2	-7,3	-6,1
8000	-5,3	-10,5	-13	-13	-10,3	-5,1

### Ø160

Hz	Speed (m/s)					
	2	4	6	8	10	12
63	14,1	5,3	-1,3	-5,6	-7,7	-7,6
125	6,2	1,3	-2,5	-5,3	-7,1	-7,8
250	1	-1	-2,6	-4	-5,1	-5,9
500	-4,8	-4,5	-4,5	-4,8	-5,5	-6,4
1000	-7,9	-7,6	-7,5	-7,5	-7,8	-8,2
2000	-10,8	-8,1	-6,4	-5,6	-5,7	-6,8
4000	-11	-9,4	-8,2	-7,3	-6,7	-6,5
8000	-2,4	-8,8	-12,5	-13,3	-11,3	-6,6

### Ø200

Hz	Speed (m/s)					
	2	4	6	8	10	12
63	12,4	6,7	2	-1,6	-4,1	-5,5
125	15,1	8,1	2,7	-0,9	-2,9	-3,2
250	-3,5	-2,4	-2	-2,3	-3,3	-5
500	-9,5	-6,7	-5	-4,6	-5,4	-7,3
1000	-11,9	-8,6	-6,6	-5,8	-6,2	-7,8
2000	-14,5	-10,4	-7,5	-5,9	-5,6	-6,6
4000	-9,3	-9,4	-9,2	-8,6	-7,7	-6,4
8000	1,1	-7,2	-12,4	-14,5	-13,5	-9,4



## 7. ACCESSORIES AND SPARE PARTS

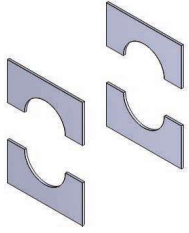

Arch infill panels for installation from Ø 100 to Ø 200 (plasterboard thickness 12.5 mm or promatect 100 thickness 12mm)

TAMP-WH25-Ø

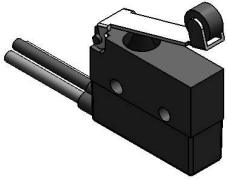

closed blade microswitch (num.1)

FBCFC

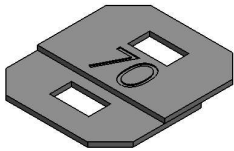

Thermofuse with 70 °C setting for FBC

FBC70



Terminal valve

VP-FBC-ØXYZ



Installation strip width 100 mm (required **only** for installation of two dampers at a distance of less than 200mm, on a light vertical wall, only with rock wool sealing)

BELT-FBC-ØXYZ

## 8. HOW TO ORDER

Code	
<b>Product type</b>	FBC Circular fire damper butterfly type
	1 Classification EI 60 S without terminal valve
<b>Model</b>	4 Classification EI 90 S without terminal valve
	7 Classification EI 120 S without terminal valve
<b>Dimension</b>	XYZ Nominal diameter (mm)
Examples	Code
Fire damper EI 120 S without valve and without microswitch Ø 200	FBC7-N-S0-200
Fire damper EI 60 S without valve and without microswitch Ø 100	FBC1-N-S0-100
Fire damper EI 90 S without valve and without microswitch, Ø 125	FBC4-N-S0-125

## 9. SPECIFICATION TEXT

### 9.1. Circular fire damper series FBC Butterfly

#### Description

- FBC1, FBC4, FBC7 circular fire damper tested for fire resistance and smoke seal with 300 Pa depression as per EN 1366-2, classified according to EN 13501-3 and CE marked according to European Regulation UE 305/2011 and EN 15650 standard.
- Allows maximum safety for fire protection inside buildings providing perfect heat insulation and smoke tightness.
- Technical characteristics
- Available diameters from 100 to 200 mm
- Case made from galvanized sheet steel, with a total length of 50 mm equipped with duct connection gaskets.
- Closing mechanism with thermal release and manual reset
- Blade damper made from calcium silicate insulating material, rotating on steel gudgeon pins, complete with polyethylene gasket for the air seal of cold smoke, as per EN 1366-2
- Thermal, expanding graphite gasket
- Thermal fuse with melting point certified ISO 10294-4 at 70 °C
- Absence of thermal bridge between the faces of the installation wall

#### Installation

- Installation within vertical rigid walls made from aerated concrete blocks, standard concrete or masonry with a minimum thickness of 100 mm and minimum density of 500 kg/m<sup>3</sup>
- Installation within gypsum block walls (carreaux de plâtre) minimum thickness 100 mm
- Installation within light plasterboard walls with minimum thickness of 100 mm
- Installation within lightweight security plasterboard walls (firewalls, brandwände) with metal blade, minimum thickness 100 mm
- Installation within concrete floors or aerated concrete with minimum thickness 100 mm (FBC1, FBC4) or 150 mm (FBC7) and minimum density 550 kg/m<sup>3</sup>
- Installation with Fire Batt (Weichschott) sealing within vertical rigid walls made from aerated concrete blocks, standard concrete or masonry with minimum thickness 100 mm and minimum density 550 kg/m<sup>3</sup>
- Installation with Weichschott sealing within lightweight plasterboard and security walls (firewalls, brandwände) minimum thickness 100 mm
- Installation with Fire Batt (Weichschott) sealing within concrete floors or aerated concrete with minimum thickness 100 mm (FBC1, FBC4,) or 150 mm (FBC7) and minimum density 550 kg/m<sup>3</sup>
- Fire resistance characteristics independent from direction of the source of the fire according to EN 1366-2 article 6.2
- The fire damper can be installed with the blade axis positioned vertically or horizontally or tilted at any angle.

#### Accessories

- Microswitch with three NO/NC position detecting connectors for open and closed damper
- Polyethylene valve for installation with valve and transfer

## 10. REVISION INDEX

Revision n°	Date of issue	Description
19/11	2019/11	First issue
20/02	2020/02	Ø180 remove
20/10	2020/10	<p>Updated section:</p> <ul style="list-style-type: none"> <li>• Installation</li> <li>• Not allowed uses</li> <li>• Periodic inspection and cleaning</li> </ul> <p>Updated table:</p> <ul style="list-style-type: none"> <li>• Fire resistance classification according to EN 13501-3-2009</li> </ul> <p>General improvements</p>
24/01	2024/01	<p>Product upgrade:</p> <ul style="list-style-type: none"> <li>• Removal of outer bands on the duct</li> <li>• Validation of the use of calcium silicate for infill in stone wool installation</li> </ul> <p>Updated table:</p> <ul style="list-style-type: none"> <li>• Extended fire resistance classification according to EN 13501-3:2009</li> </ul> <p>Added:</p> <ul style="list-style-type: none"> <li>• Vertical gypsum block wall installation</li> <li>• Lightweight vertical safety wall installations</li> </ul>



**[www.lindab.com](http://www.lindab.com) - Fire dampers are manufactured by MP3 Srl [www.mp3-italia.it](http://www.mp3-italia.it)**

As the manufacturer is constantly improving its products, the aesthetic or dimensional features, the technical data, the equipment and accessories indicated could be subject to variations.

Respect the environment, do not print this manual if not necessary.



## Good Thinking

**At Lindab**, good thinking is a philosophy that guides us in everything we do. We have made it our mission to create a healthy indoor climate – and to simplify the construction of sustainable buildings. We do that by designing innovative products and solutions that are easy to use, as well as offering efficient availability and logistics. We are also working on ways to reduce our impact on our environment and climate. We do that by developing methods to produce our solutions using a minimum of energy and natural resources, and by reducing negative effects on the environment. We use steel in our products. It's one of few materials that can be recycled an infinite number of times without losing any of its properties. That means less carbon emissions in nature and less energy wasted.

**We simplify construction**