



Lindab **LinFlow-A**

2-way control valves



2-way control valves

LinFlow-A



Description

2-way control valve with push fitting connection and toolless presetting to be controlled by thermoelectric actuators. The valves are specially developed for the demands of chilled beams and other waterborne products. Equipped with Lindab thermostatic actuators, the valves can achieve a linear valve characteristic (best with APR-40405), which guarantees best temperature control and lowest energy loss during operation. The special valves show extremely low sound generation in combination with Lindab chilled beams which offers a wider range for recommended pressure loss over the beam. A white protective cap with Lindab logo and a printed logo on the valve body easily identifies the models.

- Specially developed for chilled beams
- Fast push fitting connections (for copper pipes)
- Toolless presetting
- Brass finish
- Connection to actuator: M28 x 1.5 [mm]

For straight version, go to [LinFlow-S](#) .

Dimensions

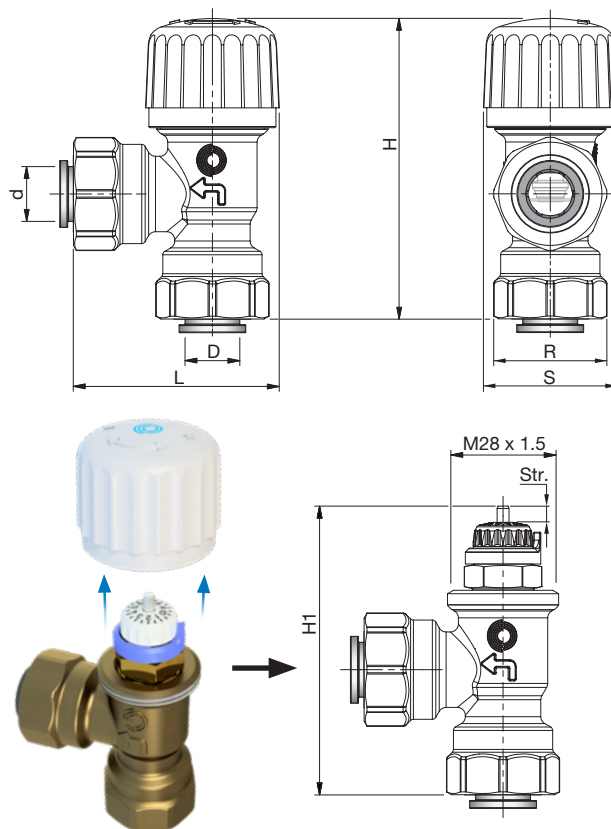

Picture 1: Valve dimensions

D x d	L	H	H1	R	S	Str.	Weight [g]
12 x 12	51.8	75.5	72.5	28.5	33.7	3	238

Table 1: Valve dimensions in [mm].

Dimensions with actuator A-40405

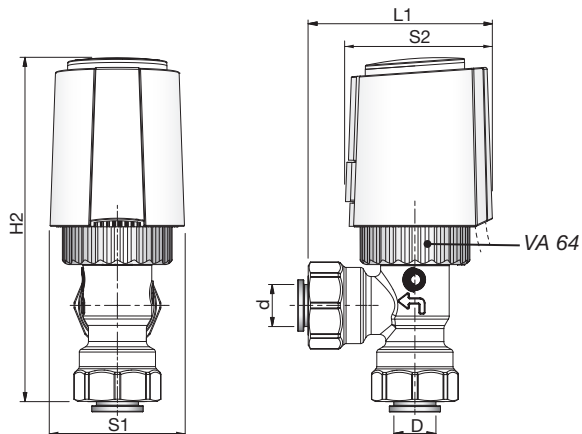

Picture 2: Valve with adapter VA 64 and actuator A-40405.

Dimensions with actuator APR-40405

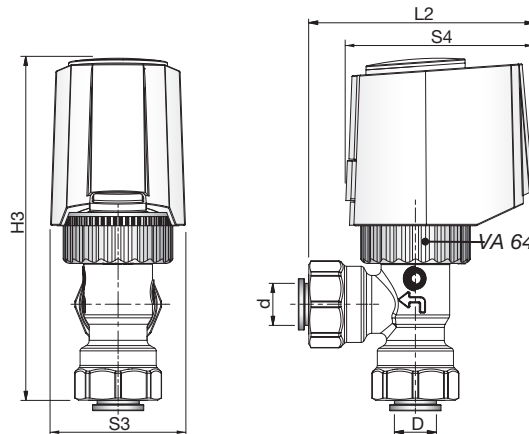

Picture 3: Valve with adapter VA 64 and actuator APR-40405.

D x d	L1	L2	H2	H3	S1	S2	S3	S4
12 x 12	60.4	73.6	113	112	44.3	48.4	44.3	61.5

Table 2: Valve and actuator dimensions in [mm].

2-way control valves

LinFlow-A

LinFlow-A with adapter and actuator

Valve LinFlow-A Adapter VA 64 Actuator APR-40405

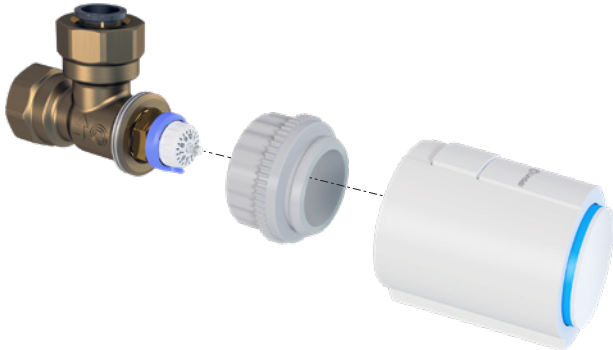

Picture 4: Remove the handwheel (8), do the presetting of the valve, the [adapter VA 64](#) and [actuator](#) can easily be attached.

Presetting of valves

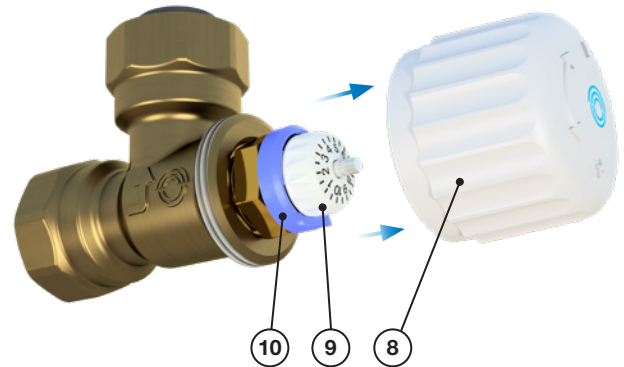

Picture 6: Remove the handwheel (8). Rotate the white presetting knob (9) till the desired position. Rotate counter clockwise (CCW) to increase and clockwise (CW) to decrease.

Technical data

Materials:

- | | |
|-------------------------|-----------------------------|
| 1. Body | CW617N (EN 12165) CuZn40Pb2 |
| 2. Headwork | CW614N (EN 12164) CuZn39Pb3 |
| 3. Stem | AISI303 |
| 4. Spring | AISI302 |
| 5. O-Ring | EPDM-X |
| 6. Gland | CW614N (EN 12164) CuZn39Pb3 |
| 7. Presetting screw | CW614N (EN 12164) CuZn39Pb3 |
| 8. Handwheel | ABS |
| 9. Presetting knob | nylon GF |
| 10. Presetting ring | nylon GF |
| 11. Shutter | CW614N (EN 12164) CuZn39Pb3 |
| 12. Half Cartridge body | CW614N (EN 12164)CuZn39Pb3 |
| 13. Clip | Acetal copolymer |
| 14. O-Rings | EPDM-X |

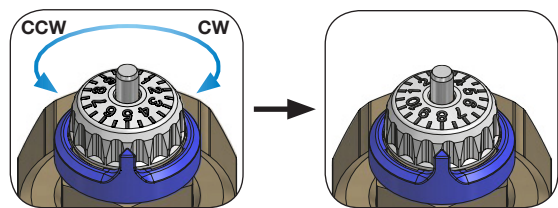

Picture 7: Example: changing the position from 5 to 8, (Increasing). Turn the presetting knob (CCW) until the blue presetting ring indicator reads 8.

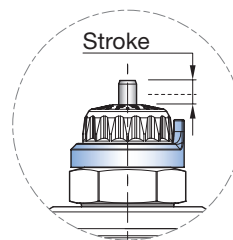

F.C.-Stem stroke -0 [mm]
=> valve fully closed

F.O.-Stem stroke -3 [mm]
=> valve fully open

Picture 8: Stem stroke 0 - 3 [mm]

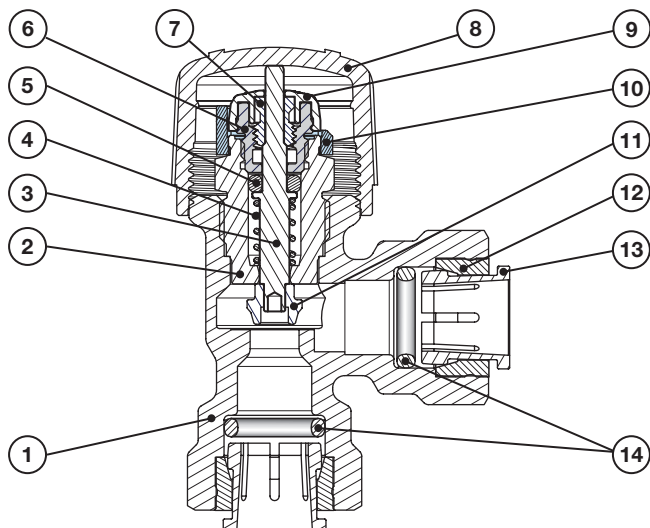

Picture 5: Section view of LinFlow-A showing internal parts.

Pressure drop diagrams / Presetting position

$$\Delta p_w = \left(\frac{q_w}{K_v} \right)^2 \quad q_w = K_v \times \sqrt{\Delta p_w}$$

Where:

q_w : is the water flow rate [m³/h]

K_v : is the flow rate factor [m³/h]

Δp_w : is the pressure drop across the valve [bar]

Find presetting position for the desired K_v value in the corresponding diagram 1 on the following pages.

2-way control valves

LinFlow-A

LinFlow-A-12

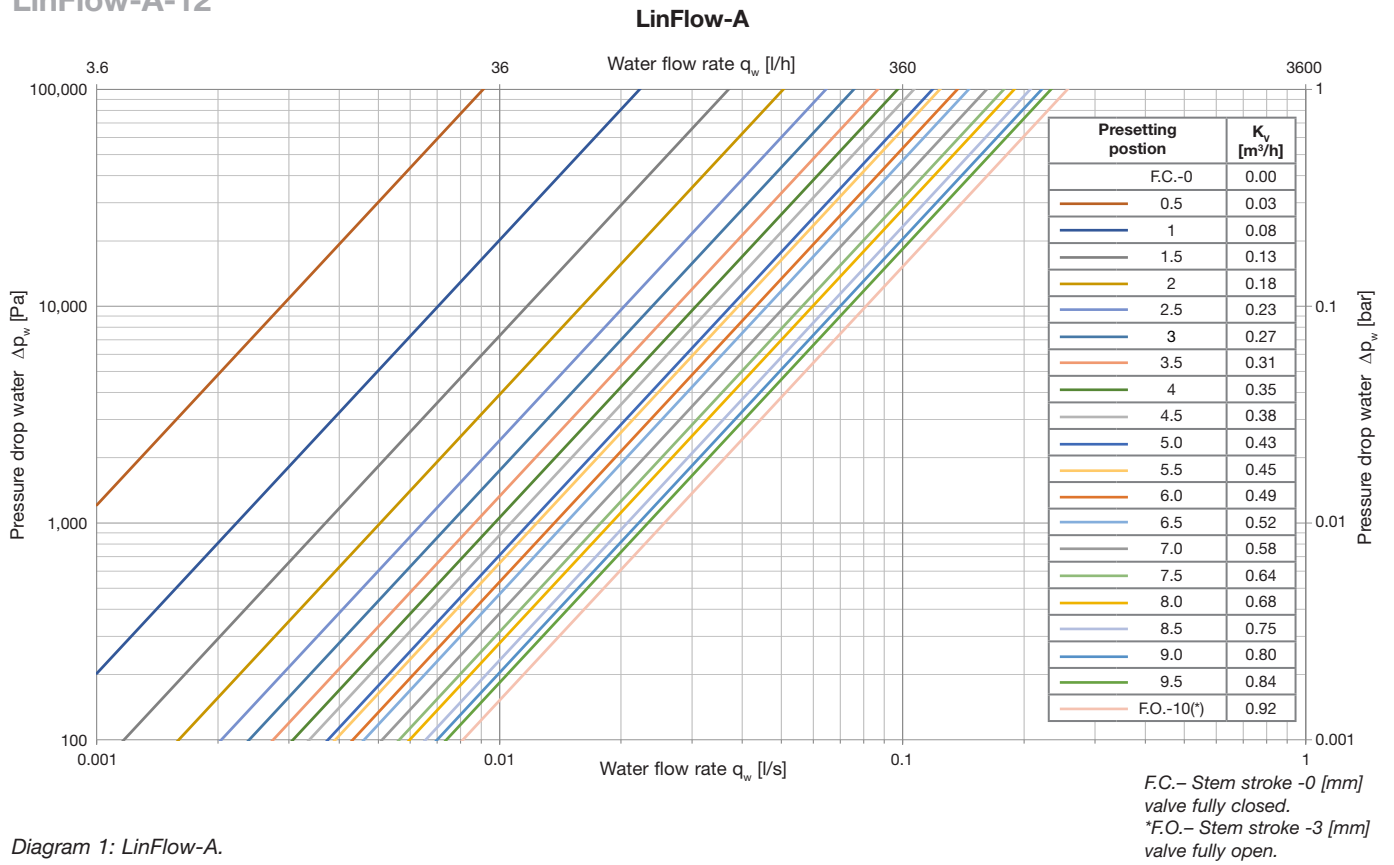

Diagram 1: LinFlow-A.

2-way control valves

LinFlow-A

Technical data

Max. static pressure: at 23 [°C] 10 [bar] - non shock
 at 70 [°C] 7 [bar] - non shock

Pressure class: PN10
 Max. differential pressure: 2.5 [bar]
 Max. temperature: 70 [°C]

K_v 's setting: 0.03 - 0.92 (according to diagram 1).

The valves can be use in combination with both copper and PEX pipes. Support sleeves should be used for PEX (please refer to the supplier data sheet).

Available thermoelectric actuators and adapter

A-40405

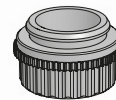
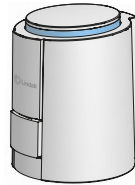

Thermoelectric actuator
 A-40405 24 V on/off NC,
 1m, non-halogen cable
 (684601)
 Adapter VA 64 M28x1.5
 (686565)

APR-40405

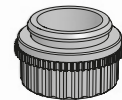
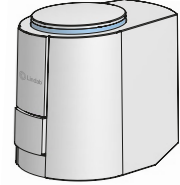

Thermoelectric actuator
 APR-40405 24 V mod. NC,
 1m, non-halogen cable
 (684667)
 Adapter VA 64 M28x1.5
 (686565)

Picture 9: Available actuators and [adapter](#).

For additional information please refer to the "[Actuators](#)" document.

Installation procedure

(1) Cut the pipe in the desired length, using a pipe cutter. Prepare the ends of the pipe, by using a deburring tool to prevent O-rings seal being damaged. When properly prepared, 1 mm of the outer surface of the pipe ends should be angled at 30°. It is important that the pipe is properly deburred. It's recommended to use pipe liners on thin walled copper pipes and PEX. Push the pipe into the pipe stop.

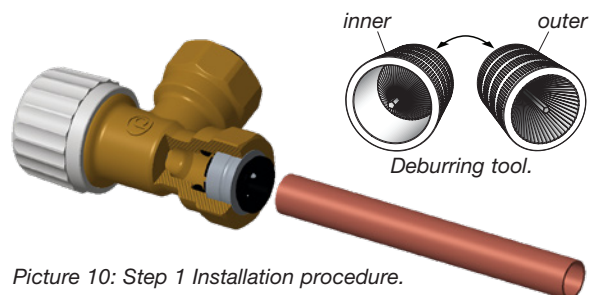

Picture 10: Step 1 Installation procedure.

(2) The fitting will grip the pipe before it seals. Be careful that the pipe is fully inserted till to the pipe stop, also pull the pipe to check it is secure. The stainless-steel collet/clips teeth grip the pipe whilst the O-rings provide a permanent leak proof seal.

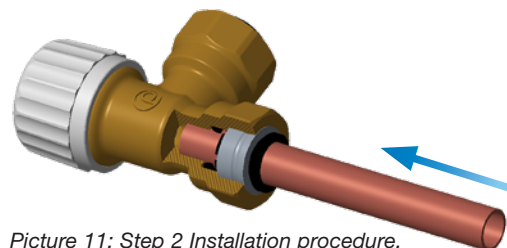

Picture 11: Step 2 Installation procedure.

Disassembly procedures

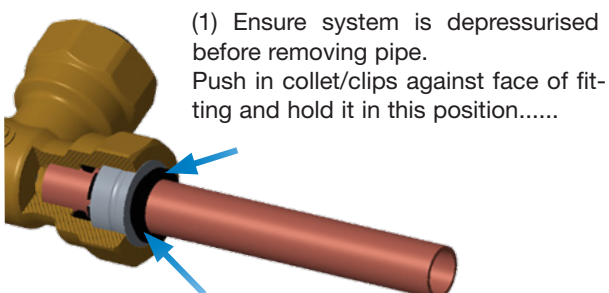

Picture 12: Step 1 disassembly procedure.

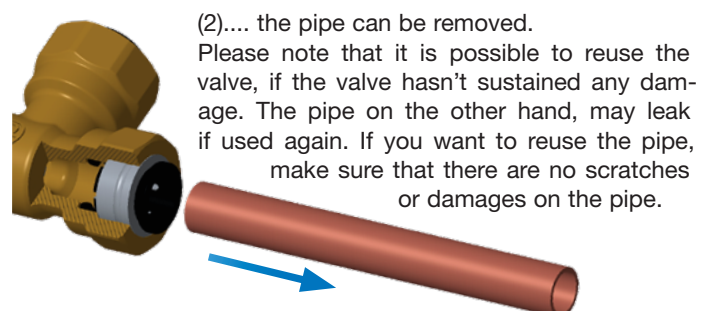

Picture 13: Step 2 disassembly procedure.

2-way control valves

LinFlow-A

Use conditions

The valve must be mounted with the arrow in the direction of the water flow indicated on the valve's body. Mounting it in the wrong direction CANNOT GUARANTEE THE CORRECT OPERATION OF THE VALVE.

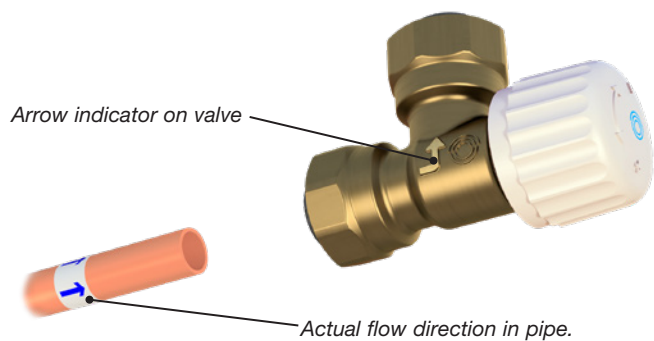

Picture 14: Flow direction in pipe and correct mounting of valve.

Accessories

For additional accessories, e.g. flexible hoses, refer to the [accessories](#) document.

Order code

Product	LinFlow-A	12
Type:		
LinFlow-A (angled)		
Dimensions:		
12 [mm]		

For straight version, go to [LinFlow-S](#) .



Good Thinking

At Lindab, good thinking is a philosophy that guides us in everything we do. We have made it our mission to create a healthy indoor climate – and to simplify the construction of sustainable buildings. We do that by designing innovative products and solutions that are easy to use, as well as offering efficient availability and logistics. We are also working on ways to reduce our impact on our environment and climate. We do that by developing methods to produce our solutions using a minimum of energy and natural resources, and by reducing negative effects on the environment. We use steel in our products. It's one of few materials that can be recycled an infinite number of times without losing any of its properties. That means less carbon emissions in nature and less energy wasted.

We simplify construction