

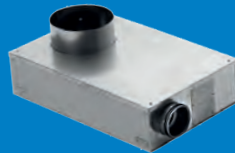

lindab | we simplify construction

# Welcome on board

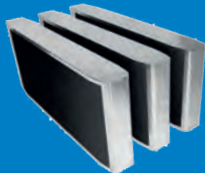

## Lindab **Marine Product Catalogue**

Ventilation solutions



# Let the journey begin





Passenger ships



Navy ships



Yachts



Offshore



Cargo ships

# A world leader in marine and offshore ventilation

Lindab has more than 35 years' experience of supplying ventilation solutions to anything from passenger ships and navy ships to oil rigs, yachts and cargo ships.

Our continuous product development has made us one of the world's leading suppliers to the HVAC industry. Our solutions for the marine and offshore industries are based on the same well-known, tested and documented products.

# Content

## Lindab Marine

Let the journey begin .....	2-3
Applications and solutions .....	6-7
We simplify construction .....	130
Certificates and approvals .....	131
References .....	134
Contact Lindab Marine .....	134

## General product information

Dimensions .....	124
Tolerances .....	125
Materials .....	126
The Safe system .....	127

## Insulated

<b>Ducts</b>	INSR .....	9
	INSRIP .....	10
<b>Bends</b>	INBU90 .....	11
	INBU60 .....	12
	INBU45 .....	13
	INBU30 .....	14
	INBU15 .....	15
<b>Reducers</b>	INRCFU .....	16
	INRCU .....	18
<b>Transition pieces</b>	ITPU .....	20
	INRF3 .....	21
	INRM3 .....	22
	INALFM .....	23
	INALMM .....	24
<b>T-piece</b>	INTCU .....	25
<b>Couplings and female couplings</b>	INNPU .....	27
	INMF .....	28
<b>End caps</b>	INBFC .....	29
	INBMC .....	30
	INCCF .....	31
	INCCM .....	32

## Non insulated

<b>Duct</b>	SR .....	33
<b>Bends</b>	BU 90° .....	35
	BU 45° .....	36
	BU 30° .....	37
	BU 15° .....	38
<b>Reducers</b>	RCU .....	39
	RCFU .....	40
	RLU .....	41
<b>Saddle</b>	PSU .....	42
<b>T-pieces</b>	TCU .....	43
	TCPU .....	44
	TSTCU .....	45
<b>Take-offs</b>	ILU .....	46
	ILRU .....	47
	ILF .....	48
	ILRNU .....	49
	ESNU .....	50

<b>Couplings and female couplings</b>	NPU .....	51
	SNPU .....	52
	MF .....	53
	SMFU .....	54

<b>End caps</b>	EPF .....	55
	ESU .....	56

## Silencers

<b>Circular silencers</b>	SLU .....	57
	LRCA .....	58
	SLFA 50 .....	59

<b>Rectangular silencers</b>	SLRS .....	60
	SLRA .....	62

## Bulkhead penetrations

<b>Bulkhead penetrations</b>	RGN .....	64
	RGIN .....	65
	SKNPUK .....	66

## Dampers and measure units

<b>Dampers</b>	INDRU .....	67
	DRU .....	68
	INDSU .....	69
	DSU .....	70
	INDTU .....	71
	DTU .....	72
	INDTMU .....	73

<b>Non-return dampers</b>	INDOSU .....	74
	DOSU .....	75
	RKUIN .....	76

<b>Measure unit dampers</b>	DIRU .....	77
	FMDU .....	78

<b>Constant flow dampers</b>	DAU .....	79
	DA2EU .....	80
	DAVU .....	81

## Air terminals

<b>Cabin units</b>	HPBDC .....	82
	HPB .....	83
	PKAN .....	84
	PCAN .....	85
	LKAN .....	86
	LCAN .....	87

<b>Integra</b>	PC6 .....	88
	PC7 .....	89
	RC14 .....	90
	RC15 .....	91
	NC19 .....	92

<b>Versio</b>	PS1 .....	93
	PS8 .....	94
	RS14 .....	95
	RS15 .....	96

<b>Lineo</b>	MTL .....	97
	STB/STU .....	98

<b>Plenum boxes</b>	VBA .....	99
	WB .....	100



# Content

<b>Nozzles</b>	GD.....	101
	DNOC.....	102
<b>Grilles</b>	RGS.....	103
	B3020/B.....	104
	C20.....	105
	G20.....	106
	F20.....	107
<b>Control valves</b>	KU.....	108
	KSU.....	109
	URH.....	110
	KI.....	111
	KIR.....	112

## Mounting systems

<b>Suspensions clamps</b>	UV25.....	113
	UVH25.....	114
	UVHM25.....	115
	UVHGM25.....	116
	INUV25.....	117
	INUVG25.....	118
<b>Duct clamps</b>	MDC.....	119
<b>Tape, screws and rivets</b>	MT TAPE.....	120
	RAI TAPE.....	121

## Other ventilation products

ISODEC.....	122
SRFC.....	123



# Applications and solutions

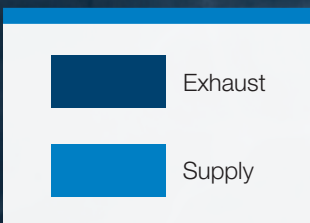
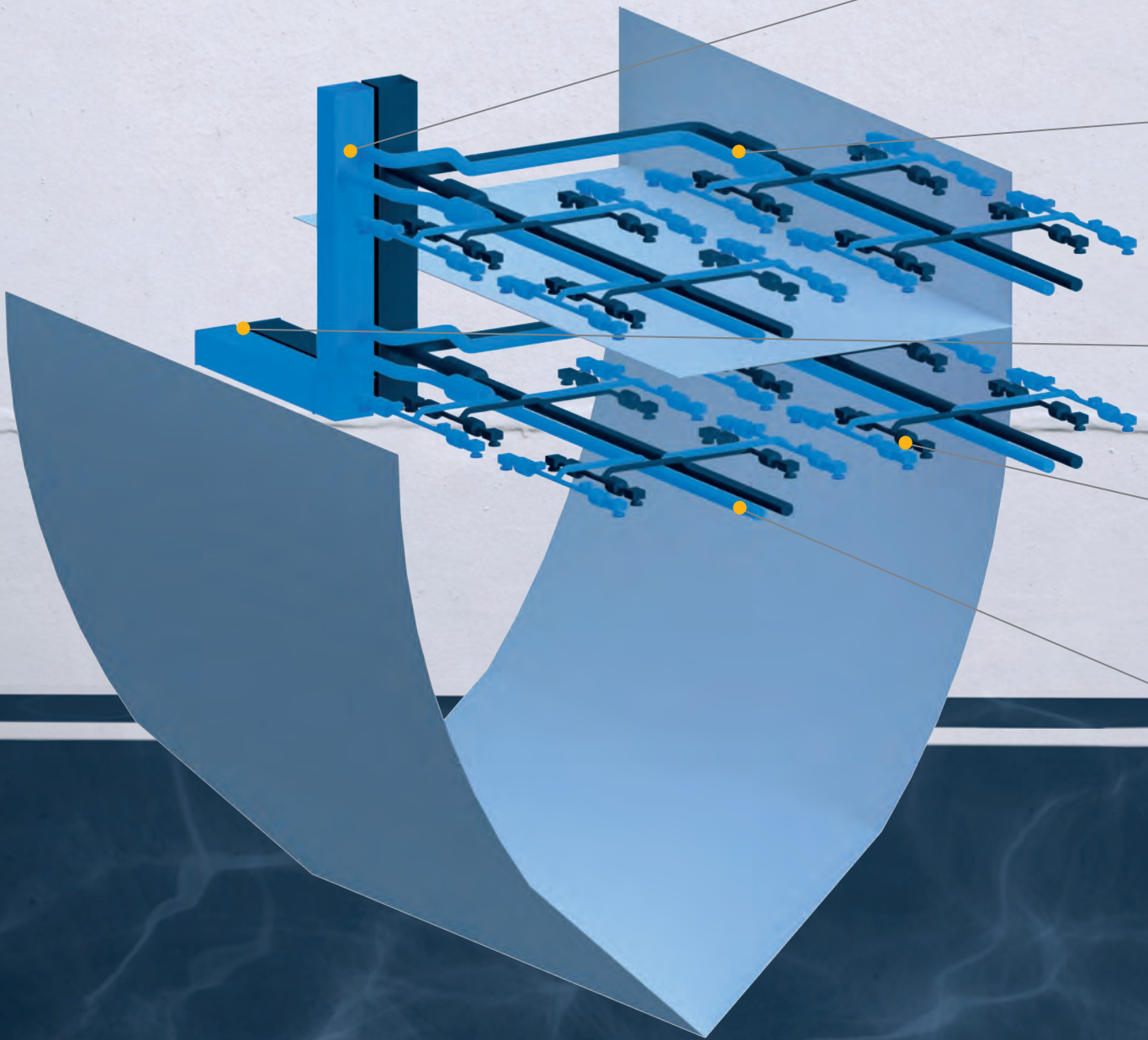



### Ducts and fittings

- Circular ducts and fittings non-insulated for Exhaust
- Circular ducts and fittings insulated for Supply



### Circular and rectangular silencers

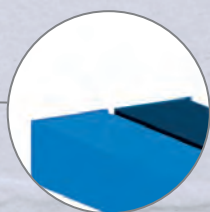

### Rectangular splitter silencers



### Boxes and diffusers



### Mounting systems and accessories





Lindab **Marine**  
Ventilation solutions



# Ducts

# INSR



## Dimensions

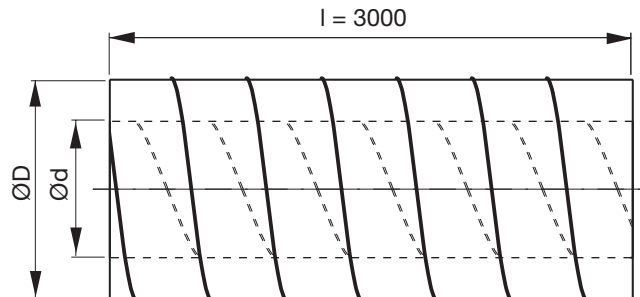

## Description

The duct is double-jacketed and insulated with mineral wool.

### NB.

No Safe Click marking on insulated ducts.

Ød nom	ØD mm	m <sub>l</sub> * kg
80	112	9,0
100	132	11,2
125	157	13,2
160	192	16,4
180	200	18,0
200	232	20,6
224	260	22,7
250	280	25,2
280	315	28,1
300	355	30,1
315	355	34,6

\* = weight can vary ±10%.

## Order code

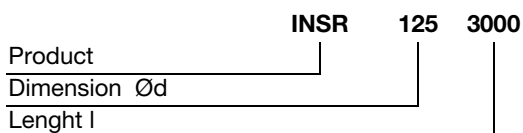

# Duct

# INSRIP



## Description

The duct is double-jacketed and insulated with mineral wool and has an attenuating effect. Internal duct is perforated.

- Perforation: 3 mm holes.
- Triangulation: 5 mm.
- Open: 32,6%.

## Dimensions

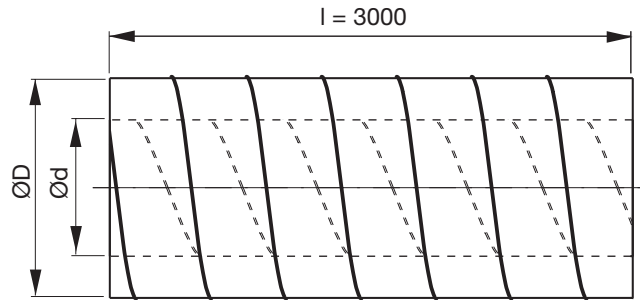

Ød nom	ØD mm	m <sub>l</sub> * kg
80	112	8,7
100	132	10,8
125	157	12,7
160	192	15,7
180	200	17,3
200	232	19,8
224	260	21,6
250	280	24,2
280	315	26,8
300	355	28,7
315	355	33,1

\* = weight can vary ±10%.

Ød / ØD mm	Length mm	Attenuation in dB for centre frequency Hz							
		63	125	250	500	1k	2k	4k	8k
80 / 112	500	2	4	7	7	11	23	28	11
	1000	3	5	8	13	28	45	37	16
	1500	4	5	8	17	38	>50	42	20
	3000	5	7	11	20	>50	>50	45	24
100 / 132	500	2	3	5	5	10	21	25	7
	1000	2	4	8	9	18	36	36	13
	1500	3	5	8	13	30	49	44	17
	3000	4	7	10	17	>50	>50	45	21
125 / 157	500	2	2	3	6	10	23	20	6
	1000	2	4	6	9	18	35	29	10
	1500	3	4	7	11	24	43	35	13
	3000	4	7	8	14	>50	>50	38	15
160 / 192	500	2	2	3	3	8	19	15	6
	1000	2	2	4	7	17	38	25	10
	1500	2	3	5	9	22	45	31	15
	3000	4	7	8	15	>50	>50	>50	23
180 / 200	500	-	1	1	2	5	13	12	6
	1000	-	1	1	2	7	19	21	8
	1500	1	2	3	3	8	24	27	11
	3000	2	3	4	7	15	31	29	13
200 / 232	500	2	2	2	3	7	20	10	5
	1000	2	2	3	5	14	32	14	7
	1500	3	3	4	7	18	41	20	12
	3000	4	5	7	15	41	>50	28	16

**NB.**  
Max. attenuation specified is 50 dB.

## Order code

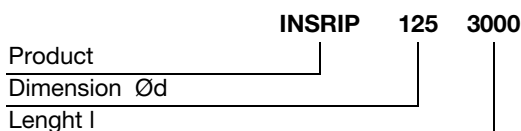

# Bend

# INBU90



## Dimensions

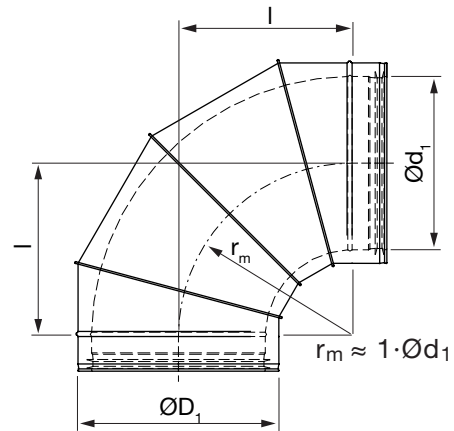

## Description

The bend is double-jacketed and insulated with mineral wool, and is supplied with Lindab Safe rubber seal on the inner dimension.

With stop bead at both inner and outer part to ensure correct installation.

Ød <sub>1</sub> nom	ØD <sub>1</sub> mm	l mm	m* kg
80	112	100	0,65
100	132	100	0,72
125	157	125	1,08
160	192	160	1,62
180	200	180	1,96
200	232	200	2,22
224	260	225	3,02
250	280	242	3,60
280	315	280	5,18
300	355	325	5,82
315	355	315	6,80

\* = weight can vary ±10%.

## Order code

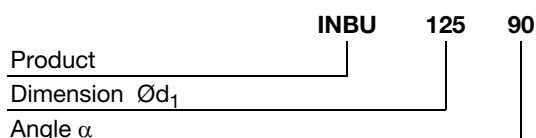

# Bend

# INBU60



## Dimensions

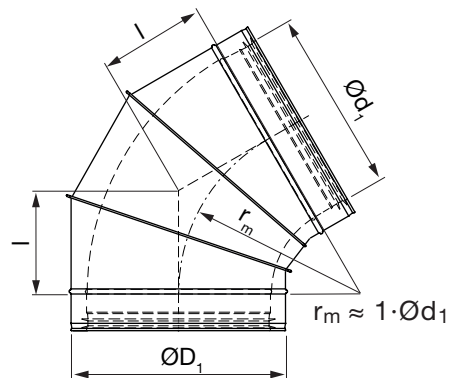

## Description

The bend is double-jacketed and insulated with mineral wool, and is supplied with Lindab Safe rubber seal on the inner dimension.

With stop bead at both inner and outer part to ensure correct installation.

Ød <sub>1</sub> nom	ØD <sub>1</sub> mm	l mm	m* kg
80	112	58	0,50
100	132	58	0,68
125	157	72	0,86
160	192	92	1,24
180	200	104	1,67
200	232	115	1,78
224	260	130	2,22
250	280	144	2,79
280	315	162	3,91
300	355	173	4,31
315	355	182	5,01

\* = weight can vary ±10%.

## Order code

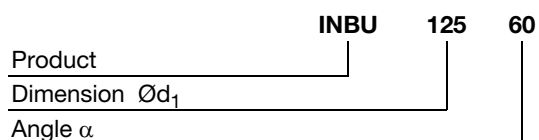

# Bend

# INBU45



## Dimensions

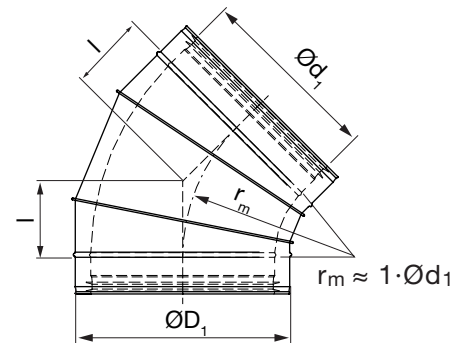

## Description

The bend is double-jacketed and insulated with mineral wool, and is supplied with Lindab Safe rubber seal on the inner dimension.

With stop bead at both inner and outer part to ensure correct installation.

Ød <sub>1</sub> nom	ØD <sub>1</sub> mm	l mm	m* kg
80	112	41	0,43
100	132	41	0,50
125	157	52	0,68
160	192	66	1,04
180	200	76	1,22
200	232	83	1,46
224	260	93	1,79
250	280	104	2,26
280	315	116	3,24
300	355	124	3,61
315	355	140	4,14

\* = weight can vary ±10%.

## Order code

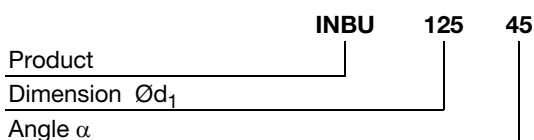

# Bend

# INBU30



## Dimensions

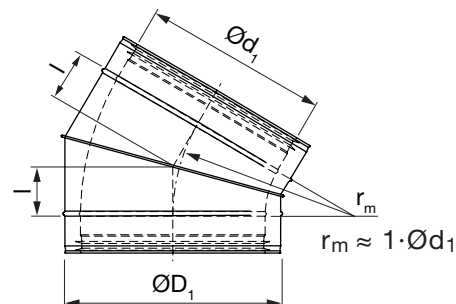

## Description

The bend is double-jacketed and insulated with mineral wool, and is supplied with Lindab Safe rubber seal on the inner dimension.

With stop bead at both inner and outer part to ensure correct installation.

Ød <sub>1</sub> nom	ØD <sub>1</sub> mm	l mm	m* kg
80	112	27	0,35
100	132	27	0,41
125	157	33	0,55
160	192	43	0,77
180	200	48	0,89
200	232	54	1,11
224	260	60	1,37
250	280	67	1,86
280	315	75	2,59
300	355	95	2,85
315	355	90	3,27

\* = weight can vary ±10%.

## Order code

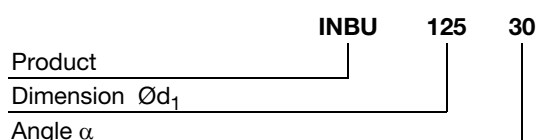

# Bend

# INBU15



## Dimensions

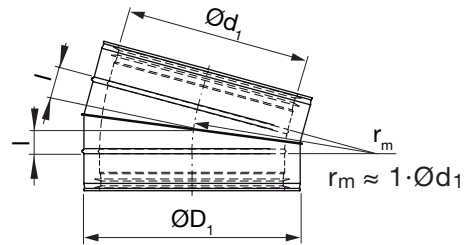

## Description

The bend is double-jacketed and insulated with mineral wool, and is supplied with Lindab Safe rubber seal on the inner dimension.

With stop bead at both inner and outer part to ensure correct installation.

Ød <sub>1</sub> nom	ØD <sub>1</sub> mm	l mm	m* kg
80	112	13	0,30
100	132	13	0,33
125	157	16	0,42
160	192	21	0,58
180	200	24	0,73
200	232	26	0,79
224	260	30	1,02
250	280	30	1,46
280	315	37	1,94
300	355	39	2,12
315	355	47	2,39

\* = weight can vary ±10%.

## Order code

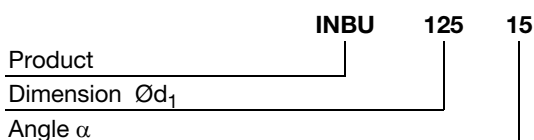

# Reducer

# INRCFU



## Dimensions

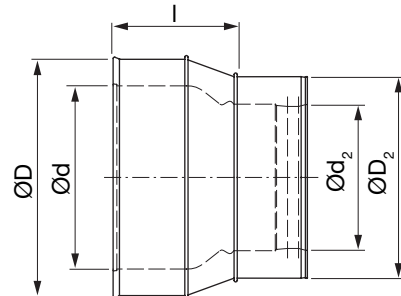

## Description

The reducer is double-jacketed and insulated with mineral wool, and is supplied with Lindab Safe rubber seal on the inner dimension ( $\text{Ø}d_2$ ) and female connection at the inner dimensions ( $\text{Ø}d$ ).

$\text{Ø}d$ nom	$\text{Ø}d_2$ mm	$\text{Ø}D$ nom	$\text{Ø}D_2$ mm	l mm	m* kg
100	80	132	112	63	0,33
125	80	157	112	75	0,41
125	100	157	132	66	0,40
160	80	192	112	94	0,65
160	100	192	132	85	0,56
160	125	192	157	72	0,57
180	80	200	112	212	1,08
180	100	200	132	185	1,04
180	125	200	157	151	0,97
180	160	200	192	103	0,79
200	80	232	112	240	1,33
200	100	232	132	92	0,76
200	125	232	157	92	0,73
200	160	232	192	78	0,69
200	180	232	200	103	0,91
224	80	260	112	277	1,52
224	100	260	132	245	1,58
224	125	260	157	211	1,47
224	160	260	192	163	1,32
224	180	260	200	135	1,19
224	200	260	232	107	1,07
250	80	280	112	332	1,95
250	100	280	132	301	2,02
250	125	280	157	137	1,36
250	160	280	192	115	1,13
250	180	280	200	191	1,62
250	200	280	232	103	1,08
250	224	280	260	131	1,36
280	80	315	112	379	2,19
280	100	315	132	347	2,26
280	125	315	157	308	2,36
280	160	315	192	260	2,19
280	180	315	200	232	2,06
280	200	315	232	205	1,97

## Order code

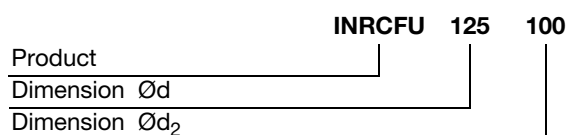



## Reducer

## INRCFU

<b>Ød nom</b>	<b>Ød<sub>2</sub> mm</b>	<b>ØD nom</b>	<b>ØD<sub>2</sub> mm</b>	<b>l mm</b>	<b>m* kg</b>
280	224	315	260	172	1,80
280	250	315	280	136	1,76
300	80	355	112	410	2,47
300	100	355	132	379	2,54
300	125	355	157	335	2,72
300	160	355	192	287	2,50
300	180	355	200	260	2,36
300	200	355	232	232	2,28
300	224	355	260	200	2,12
300	250	355	280	164	2,07
300	280	355	315	123	1,89
315	80	355	112	425	2,74
315	100	355	132	394	2,82
315	125	355	157	356	3,00
315	160	355	192	308	2,77
315	180	355	200	281	2,61
315	200	355	232	253	2,53
315	224	355	260	220	2,36
315	250	355	280	184	2,31
315	280	355	315	143	2,11
315	300	355	355	116	1,99

\* = weight can vary ±10%.



# Reducer

# INRCU



## Description

The reducer is double-jacketed and insulated with mineral wool, and is supplied with Lindab Safe rubber seal on the inner dimensions.

## Dimensions

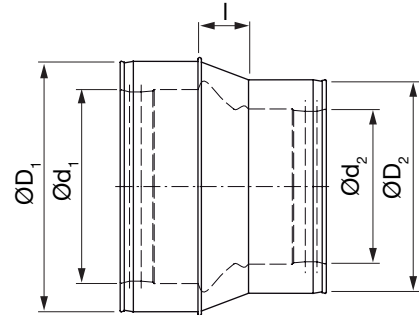

$\varnothing d_1$ nom	$\varnothing d_2$ mm	$\varnothing D_1$ nom	$\varnothing D_2$ mm	l mm	m* kg
100	80	132	112	26	0,32
125	80	157	112	36	0,41
125	100	157	132	27	0,39
160	80	192	112	55	0,63
160	100	192	132	46	0,56
160	125	192	157	34	0,54
180	80	200	112	167	1,10
180	100	200	132	140	1,03
180	125	200	157	106	0,95
180	160	200	192	58	0,77
200	80	232	112	195	1,34
200	100	232	132	52	0,78
200	125	232	157	55	0,76
200	160	232	192	39	0,68
200	180	232	200	58	0,86
224	80	260	112	232	1,51
224	100	260	132	200	1,59
224	125	260	157	166	1,50
224	160	260	192	118	1,29
224	180	260	200	90	1,13
224	200	260	232	63	1,02
250	80	280	112	267	1,98
250	100	280	132	75	2,09
250	125	280	157	70	1,36
250	160	280	192	60	1,17
250	180	280	200	126	1,79
250	200	280	232	42	1,10
250	224	280	260	29	1,14
280	80	315	112	314	2,31
280	100	315	132	282	2,39
280	125	315	157	243	2,54
280	160	315	192	195	2,32
280	180	315	200	167	2,16
280	200	315	232	140	2,05

## Order code

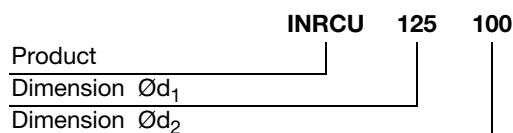

## Reducer

## INRCU

$\varnothing d_1$ nom	$\varnothing d_2$ mm	$\varnothing D_1$ nom	$\varnothing D_2$ mm	l mm	m* kg
280	224	315	260	107	1,89
280	250	315	280	71	1,83
300	80	355	112	345	2,65
300	100	355	132	314	2,73
300	125	355	157	270	2,93
300	160	355	192	222	2,70
300	180	355	200	195	2,53
300	200	355	232	167	2,43
300	224	355	260	135	2,25
300	250	355	280	99	2,08
300	280	355	315	58	2,05
315	80	355	112	360	2,91
315	100	355	132	329	3,04
315	125	355	157	291	3,21
315	160	355	192	243	2,96
315	180	355	200	216	2,80
315	200	355	232	188	2,69
315	224	355	260	155	2,54
315	250	355	280	119	2,46
315	280	355	315	78	2,33
315	300	355	355	51	2,18

\* = weight can vary  $\pm 10\%$ .



# Transition piece

ITPU



## Description

The transition piece is double-jacketed and insulated with mineral wool, and is supplied with Lindab Safe rubber seal on the inner dimension.

Used when connecting insulated duct systems to Lindab standard insulated Marine system.

## Dimensions

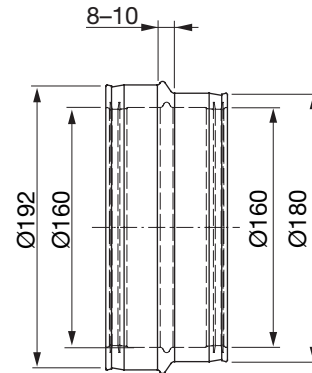

Weight: 0,41 kg

## Order code

	<b>ITPU</b>	<b>192</b>	<b>180</b>
Product			
Dimension			
Dimension			



# Transition piece

# INRF3



## Description

The transition piece, with flange is used when connecting a gasketed fitting to the bulkhead penetrations.

## Dimensions

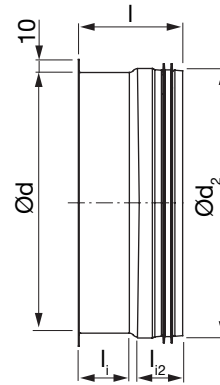

Ød nom	Ød <sub>2</sub> mm	l mm	l <sub>1</sub> / l <sub>2</sub> mm	m* kg
200	207	95	40	0,21
250	261	135	60	0,46

\* = weight can vary ±10%.

## Order code

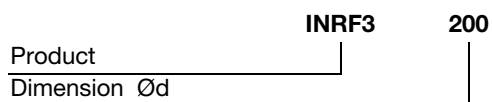

# Transition piece

# INRM3



## Description

The transition piece is supplied with Lindab Safe rubber seal.

The transition piece is used when connecting the duct system to the bulkhead penetrations.

## Dimensions

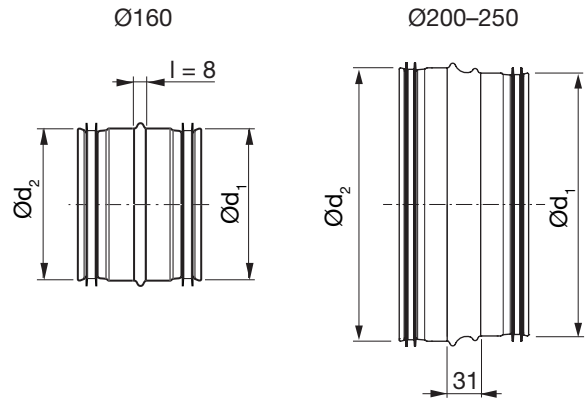

Ød <sub>1</sub> nom	Ød <sub>2</sub> mm	m* kg
160	158	0,26
200	210	0,31
250	263,5	0,57

\* = weight can vary ±10%.

## Order code

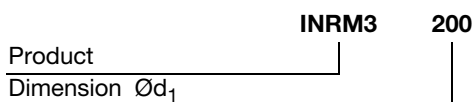

# Transition piece

# INALFM



## Description

The transition piece with female coupling, is double-jacketed and insulated at the large end and supplied with Lindab Safe rubber seal at the small end. It's used when going from insulated to non insulated ductwork.

## Dimensions

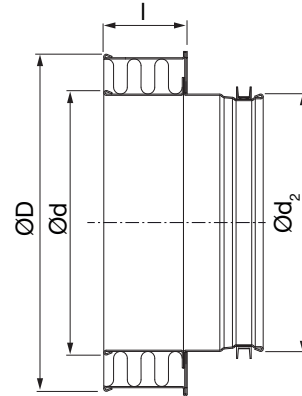

Ød nom	Ød <sub>2</sub> mm	ØD nom	l mm	m* kg
80	80	112	40	0,20
100	100	132	40	0,24
125	125	157	40	0,30
160	160	192	40	0,38
180	180	200	40	0,38
200	200	232	40	0,47
224	224	260	40	0,53
250	250	280	60	0,76
280	280	315	60	0,87
300	300	355	60	0,92
315	315	355	60	1,06

\* = weight can vary ±10%.

## Order code

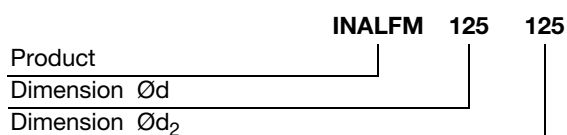

# Transition piece

# INALMM

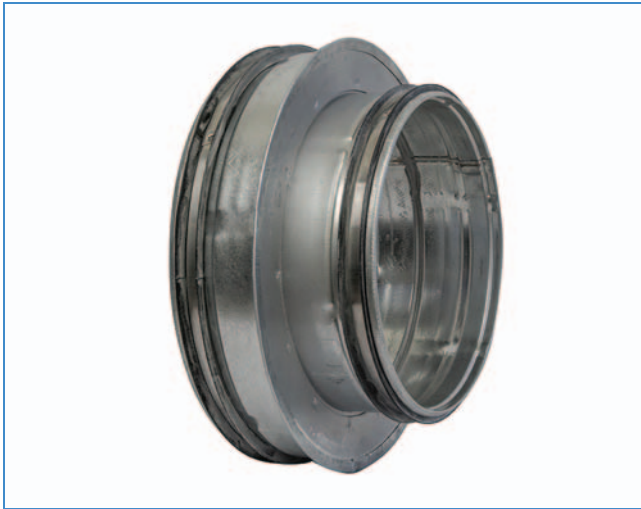

## Dimensions

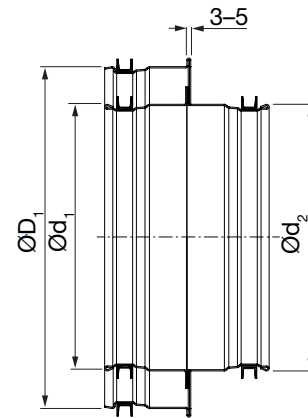

## Description

The transition piece is double-jacketed and insulated at the large end and supplied with Lindab Safe rubber seal in the inner dimension. It's used when going from insulated to non insulated ductwork.

Ød <sub>1</sub> nom	Ød <sub>2</sub> mm	ØD <sub>1</sub> nom	m* kg
80	80	112	0,18
100	100	132	0,22
125	125	157	0,28
160	160	192	0,35
180	180	200	0,36
200	200	232	0,46
224	224	260	0,52
250	250	280	0,71
280	280	315	0,91
300	300	355	0,98
315	315	355	1,10

\* = weight can vary ±10%.

## Order code

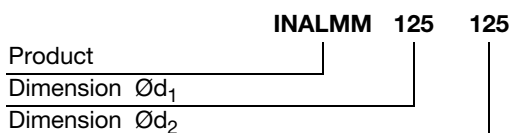



# T-piece

# INTCU



## Dimensions

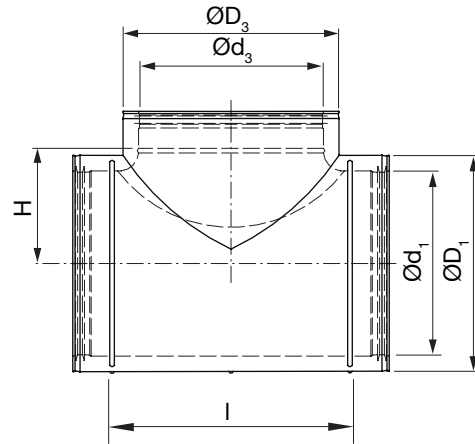

## Description

The T-piece is double-jacketed and insulated with mineral wool, and is supplied with Lindab Safe rubber seal on the inner dimension.

With stop bead at the main connections, to ensure correct installation.

$\text{Ød}_1$ nom	$\text{Ød}_3$ mm	$\text{ØD}_1$ nom	$\text{ØD}_3$ mm	l mm	H mm	m* kg
80	80	112	112	140	52	0,66
100	80	132	112	97	60	0,62
100	100	132	132	132	66	0,71
125	80	157	112	97	72	0,78
125	100	157	132	130	78	0,85
125	125	157	157	165	83	1,02
160	80	192	112	140	92	1,11
160	100	192	132	130	95	1,03
160	125	192	157	166	100	1,22
160	160	192	192	209	105	1,43
180	80	200	112	140	102	1,16
180	100	200	132	175	105	1,42
180	125	200	157	215	110	1,55
180	160	200	192	260	115	1,81
180	180	200	200	285	115	2,11
200	80	232	112	140	112	1,34
200	100	232	132	175	116	1,67
200	125	232	157	215	116	1,91
200	160	232	192	209	125	1,73
200	180	232	200	285	125	2,47
200	200	232	232	249	125	1,98
224	80	260	112	140	124	1,75
224	100	260	132	175	127	1,90
224	125	260	157	215	132	2,18
224	160	260	192	260	137	2,44
224	180	260	200	285	137	2,77
224	200	260	232	346	137	3,14
224	224	260	260	346	137	3,26
250	80	280	112	156	137	2,08
250	100	280	132	175	140	2,24
250	125	280	157	220	145	2,58
250	160	280	192	256	150	2,77
250	180	280	200	306	150	3,17
250	200	280	232	306	150	3,27

## Order code

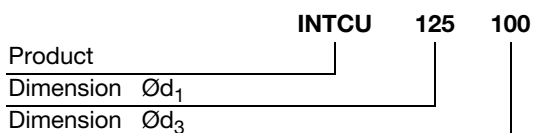

## T-piece

## INTCU

Ød <sub>1</sub> nom	Ød <sub>3</sub> mm	ØD <sub>1</sub> nom	ØD <sub>3</sub> mm	l mm	H mm	m* kg
250	224	280	260	350	150	3,57
250	250	280	280	296	150	3,21
280	80	315	112	156	155	2,42
280	100	315	132	175	155	2,45
280	125	315	157	220	160	2,86
280	160	315	192	256	165	3,11
280	180	315	200	306	165	3,43
280	200	315	232	306	165	3,51
280	224	315	260	350	165	4,21
280	250	315	280	350	165	4,04
280	280	315	315	390	165	4,41
300	80	355	112	156	162	2,91
300	100	355	132	175	165	3,04
300	125	355	157	220	170	3,45
300	160	355	192	256	175	4,00
300	180	355	200	306	175	4,26
300	200	355	232	306	175	4,46
300	224	355	260	350	175	4,69
300	250	355	280	350	175	5,01
300	280	355	315	390	175	5,21
300	300	355	355	430	175	5,55
315	80	355	112	156	170	3,09
315	100	355	132	175	173	3,34
315	125	355	157	220	178	3,65
315	160	355	192	256	182	4,05
315	180	355	200	306	182	4,23
315	200	355	232	306	182	4,59
315	224	355	260	350	182	5,13
315	250	355	280	350	182	5,30
315	280	355	315	390	182	5,31
315	300	355	355	430	182	5,99
315	315	355	355	363	182	5,06

\* = weight can vary ±10%.



# Coupling

# INNPU

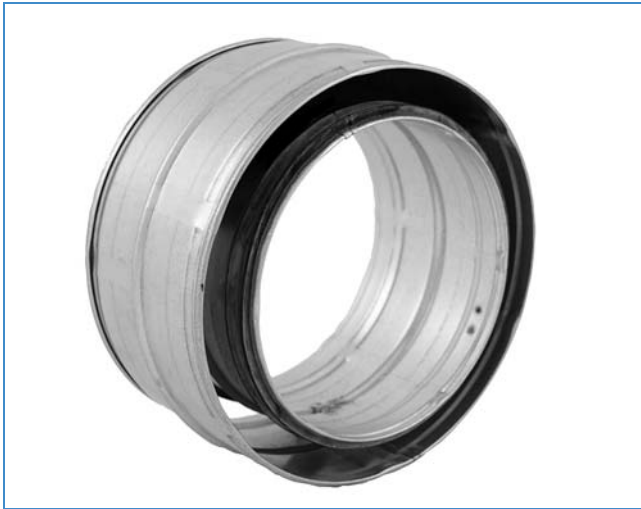

## Dimensions

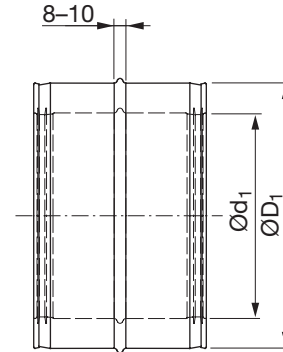

## Description

The coupling is double-jacketed and supplied with Lindab Safe rubber seal on the inner dimension and used when connecting insulated ducts. With distance ensuring that the parts are centered.

Ød <sub>1</sub> nom	ØD <sub>1</sub> mm	m* kg
80	112	0,20
100	132	0,25
125	157	0,31
160	192	0,38
180	200	0,41
200	232	0,51
224	260	0,60
250	280	0,92
280	315	1,10
300	355	1,13
315	355	1,27

\* = weight can vary ±10%.

## Order code

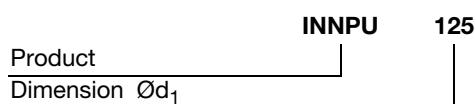

# Female coupling

INMF



## Dimensions

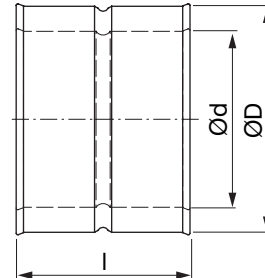

## Description

Coupling for fittings. The coupling is double-jacketed and insulated with mineral wool.

Ød nom	ØD mm	l mm	m* kg
80	112	97	0,29
100	132	97	0,32
125	157	97	0,38
160	192	97	0,47
180	200	97	0,54
200	232	97	0,57
224	260	97	0,72
250	280	139	1,13
280	315	139	1,20
300	355	139	1,27
315	355	139	1,45

\* = weight can vary ±10%.

## Order code

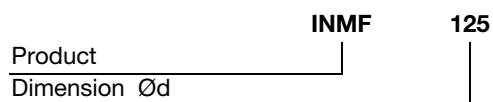

# End cap

# INBFC



## Dimensions

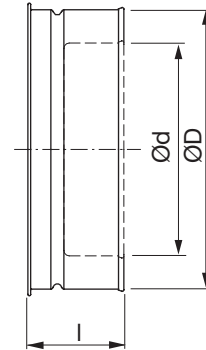

## Description

End cap is double-jacketed, insulated with mineral wool. It fits to a fitting.

Ød nom	ØD mm	l mm	m* kg
80	112	60	0,22
100	132	60	0,26
125	157	60	0,35
160	192	60	0,46
180	200	60	0,54
200	232	60	0,67
224	260	60	0,82
250	280	80	0,96
280	315	80	1,23
300	355	80	1,30
315	355	80	1,50

\* = weight can vary ±10%.

## Order code

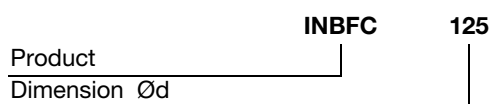

# End cap

# INBMC



## Description

The end cap is double-jacketed, insulated with mineral wool and with Lindab Safe rubber seal on the inner dimension. It fits inside a duct.

## Dimensions

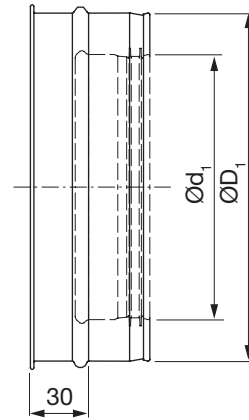

Ød <sub>1</sub> nom	ØD <sub>1</sub> mm	m* kg
80	112	0,23
100	132	0,27
125	157	0,35
160	192	0,48
180	200	0,60
200	232	0,67
224	260	0,78
250	280	1,00
280	315	1,25
300	355	1,36
315	355	1,45

\* = weight can vary ±10%.

## Order code

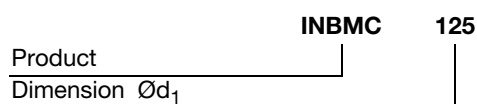

# Endcap

# INCCF



## Dimensions

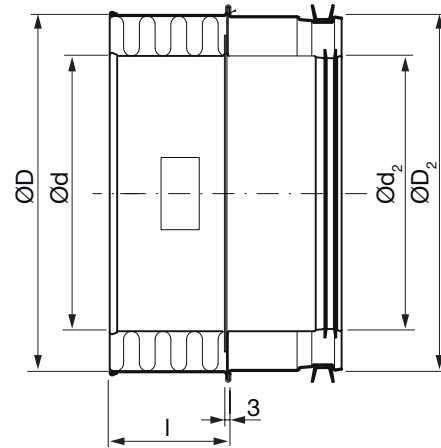

## Description

Endcap used when going from INSRIP to insulated fitting, with male connection.

Ød nom	Ød <sub>2</sub> mm	ØD nom	ØD <sub>2</sub> mm	l mm	m* kg
80	80	112	112	48	0,31
100	100	132	132	48	0,38
125	125	157	157	48	0,45
160	160	192	192	48	0,53
180	180	200	200	48	0,62
200	200	232	232	48	0,72
224	224	260	260	48	0,82
250	250	280	280	68	1,28
280	280	315	315	68	1,43
300	300	355	355	68	1,65
315	315	355	355	68	1,70

\* = weight can vary ±10%.

## Order code

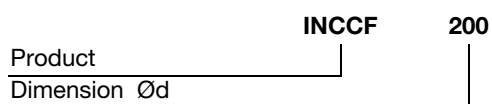

# Endcap

# INCCM



## Dimensions

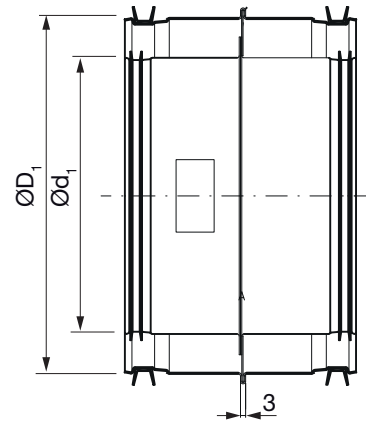

## Description

Endcap used when going from INSRIP to INSR.

Ød <sub>1</sub> nom	ØD <sub>1</sub> mm	m* kg
80	112	0,28
100	132	0,35
125	157	0,42
160	192	0,50
180	200	0,59
200	232	0,69
224	260	0,83
250	280	1,28
280	315	1,40
300	355	1,66
315	355	1,68

\* = weight can vary ±10%.

## Order code

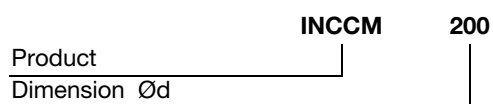



# Circular duct

SR

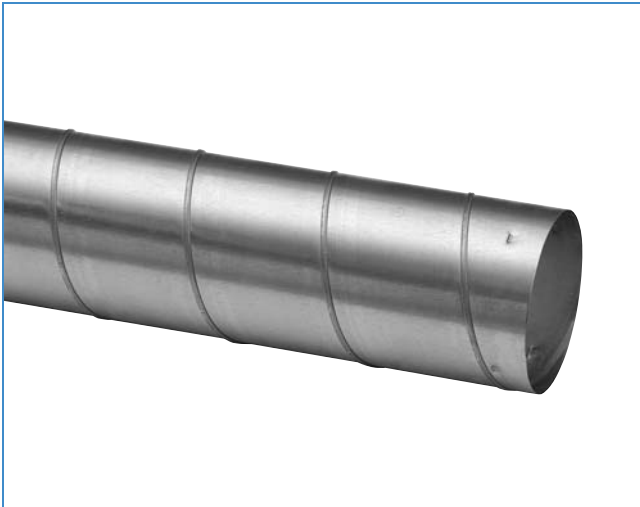

## Dimensions

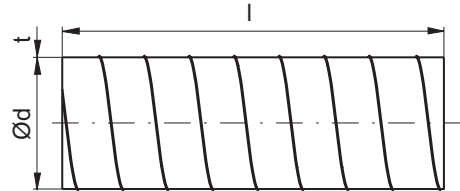

## Description

Circular duct.

Ducts are always produced locally and can therefore have different thicknesses and other specifications per country.

The ducts can be produced both with and without click function (notches).

Please specify when ordering.

Also available in other dimensions up to Ø400.

Ød std nom	O $\pi d$ m	A $\pi d^2/4$ m <sup>2</sup>	t std mm	l std mm	ml std kg/m
80	0,251	0,005	0,45	3000	0,91
100	0,314	0,008	0,45	3000	1,14
125	0,393	0,012	0,45	3000	1,41
160	0,503	0,020	0,5	3000	2,02
180	0,565	0,025	0,5	3000	2,26
200	0,628	0,031	0,5	3000	2,56
224	0,704	0,039	0,6	3000	3,42
250	0,785	0,049	0,5	3000	3,18

## Order code

	SR	200	3000	CLIC
Product				
Dimension Ød				
Length l				
Type				



# Circular duct

SR

## Technical data

### Special versions

We can supply ducts with the following special designs:

- In intermediate dimensions
- In other sheet metal thicknesses

### Extra tight, with seam seal

When extremely good sealing is required in the spiral seam, the ducts can also be supplied with a special rubber seal in the seam.

This seal is very effective at stopping leakage of vegetable oils and greases, and most petroleum products.

### Other sheet metal thicknesses

If extra stability is needed in ducts, because of high negative pressure etc., they can be supplied with thicker sheet metal than the standard. Remember that the thickness increase always reduces the inner diameter. Fittings for such special ducts must be specified separately and sometimes have to be specially made.

## Strength

### Positive pressure

In case of high positive pressure, the seal moulding lips will first start to whistle. At considerably higher pressure, the joints between the ducts will be forced apart. If you manage to fix the connections very well, the ducts will burst at their seams at even higher pressure. The high pressures needed for this to happen are not relevant to ventilation installations.

### Negative pressure

In installations with high negative pressure, there is a risk that the ducts could collapse.

This phenomenon is referred to as buckling, and can suddenly happen at the weakest point in the system. Buckling wanders along the duct, which can be completely flattened. The weakest point is frequently a "transport dent" on a duct. For this reason, only use undamaged ducts in systems which are close to the critical pressure!

### Sealing

The ability of the seal moulding to seal is different from these pressures.



# Bend

# BU 90°



## Dimensions

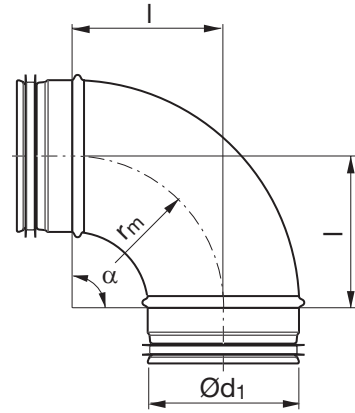

$r_m \approx 1 \cdot d_1$

## Description

Pressed and seam welded bend.

$\text{Ø}d_1$ nom	l mm	m kg
80	105	0,26
100	100	0,31
125	125	0,48
160	160	0,62
180	180	1,02
200	200	1,12
224	225	1,33
250	242	1,77

## Order code

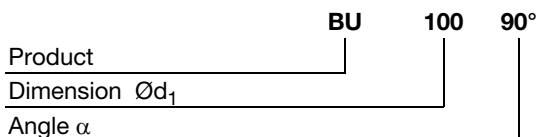

# Bend

# BU 45°



## Dimensions

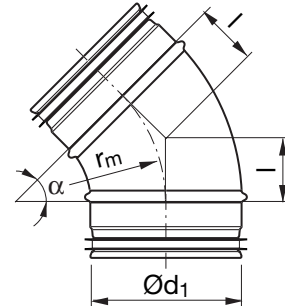

$r_m \approx 1 \cdot d_1$

## Description

Pressed and seam welded bend.

Ød <sub>1</sub> nom	l mm	m kg
80	41	0,17
100	41	0,21
125	52	0,29
160	66	0,48
180	76	0,65
200	83	0,80
224 *	93	0,82
250 *	103	1,05

## Order code

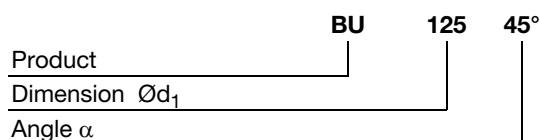

# Bend

# BU 30°



## Dimensions

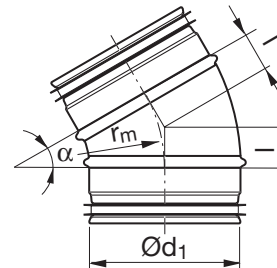

$$r_m \approx 1 \cdot d_1$$

## Description

Pressed and seam welded bend.

Ød <sub>1</sub> nom	l mm	m kg
80	27	0,15
100	27	0,18
125	33	0,20
160	43	0,32
180	48	0,51
200	54	0,62
224	60	0,72
250	67	0,91

## Order code

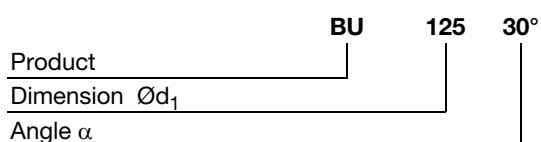

# Bend

# BU 15°



## Description

Pressed and seam welded bend.

## Dimensions

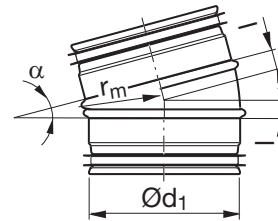

$$r_m \approx 1 \cdot d_1$$

Ød <sub>1</sub> nom	l mm	m kg
80 *	13	0,11
100	13	0,15
125	16	0,18
160	21	0,24
180 *	24	0,37
200	26	0,35
224 *	30	0,56
250 *	33	0,65

\* Segmented and lockseamed

## Order code

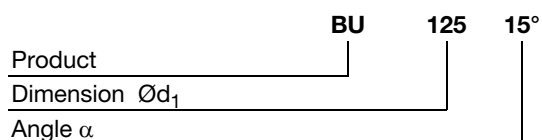

# Reducer

# RCU



## Dimensions

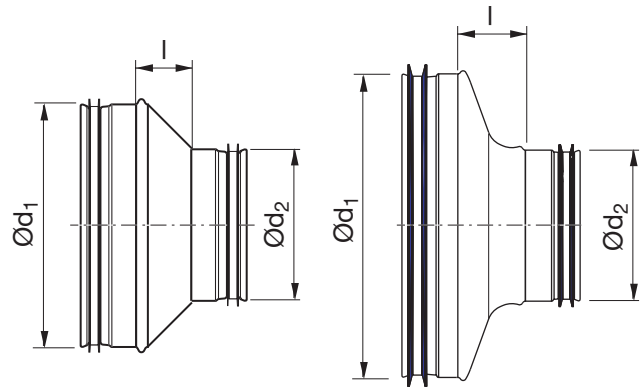

## Description

Pressed, concentric reducer to meet demands for short installation length with low pressure drop and low internal noise generation.

Also available in other dimensions up to Ø400.

Ød <sub>1</sub> nom	Ød <sub>2</sub> nom	l mm	m kg
80	63	18	0,12
100	63	30	0,17
100 *	80	26	0,18
125 *	63	38	0,2
125 *	80	36	0,16
125 *	100	27	0,21
160	80	55	0,31
160 *	100	46	0,17
160 *	125	35	0,22
180	100	55	0,24
180	125	40	0,37
180	160	20	0,26
200 *	100	46	0,22
200 *	125	55	0,30
200 *	160	39	0,29
200	180	26	0,35
224	160	44	0,53
224	180	34	0,48
224	200	24	0,45
250	125	70	0,62
250 *	160	60	0,46
250	180	47	0,59
250 *	200	42	0,46
250	224	29	0,57

\* With stream-lined transition

## Order code

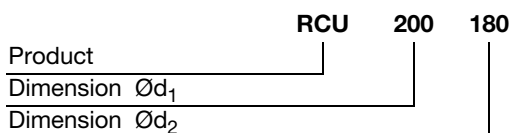

# Reducer

# RCFU



## Dimensions

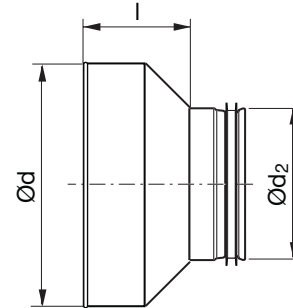

## Description

Pressed, concentric reducer with female coupling, with a 45° angle to meet demands for short installation length with low pressure drop and low internal noise generation. Ød fits outside another fitting.

Has Click function at the Safe end – has an open turned-over end.

Has normally not any Click function at the female end – hasn't any notches.

Ø 80–315 can upon order be delivered with click function at the female end as well – i.e. with notches.

Also available in other dimensions up to Ø400.

Ød nom	Ød <sub>2</sub> nom	l mm	m kg
100 *1	80	61	0,16
125 *1	80	73	0,16
125 *1	100	64	0,14
160 *	80	92	0,24
160 *1	100	83	0,16
160 *1	125	71	0,20
180	100	98	0,24
180	125	85	0,31
180	160	66	0,27
200 *1	100	84	0,23
200 *1	125	90	0,27
200 *1	160	73	0,26
200	180	63	0,32
224	160	87	0,49
224	180	76	0,46
224	200	66	0,45
250 *	125	133	0,57
250 *1	160	117	0,40
250	180	107	0,55
250 *1	200	103	0,42
250	224	89	0,53

\* With turned-over edge

1 With stream-lined transition

## Order code

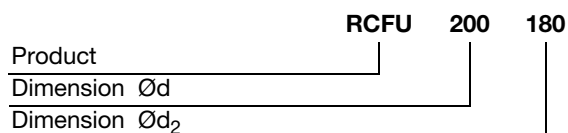



# Reducer

# RLU



## Dimensions

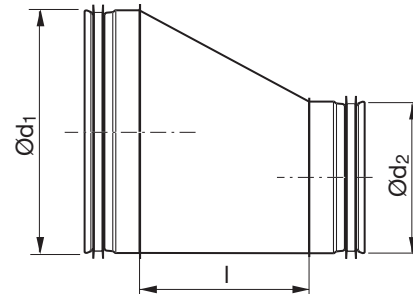

### Description

Long, tangential, hand made reducer with approx. 35° angle.

Also available in other dimensions up to Ø400.

Ød <sub>1</sub> nom	Ød <sub>2</sub> nom	l mm	m kg
100	80	58	0,18
125	80	92	0,26
125	100	64	0,24
160	80	140	0,42
160	100	112	0,40
160	125	78	0,36
180	80	167	0,51
180	100	140	0,49
180	125	106	0,46
180	160	58	0,41
200	80	195	0,61
200	100	167	0,59
200	125	133	0,55
200	160	85	0,50
200	180	58	0,46
224	100	200	0,72
224	125	166	0,68
224	160	118	0,63
224	180	90	0,58
224	200	63	0,53
250	100	236	0,94
250	125	202	0,90
250	160	154	0,87
250	180	126	0,80
250	200	99	0,75
250	224	66	0,67

### Order code

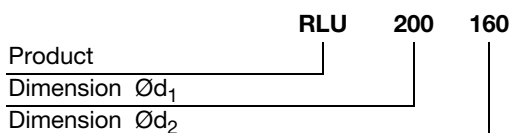

# Saddle

# PSU



## Description

Pressed saddle with aerodynamic flow radius facing the branch.

Some PSUs fit several dimensions of main pipe.

Also available in other dimensions up to Ø400.

## Dimensions

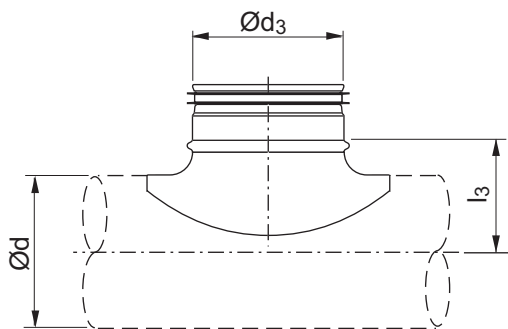

## Dimensions

Ød nom	Ød <sub>3</sub> nom	l <sub>3</sub> mm	m kg
80	80	52	0,13
100	80	60	0,14
100	100	65	0,18
125	80	75	0,13
125	100	78	0,18
125	125	83	0,25
160	80	92	0,10
160	100	95	0,18
160	125	100	0,18
160	160	105	0,26
180	80	102	0,09
180	100	105	0,19
180	125	110	0,25
180	160	115	0,27
180	180	115	0,48
200	80	112	0,09
200	100	115	0,19
200	125	115	0,25
200	160	125	0,27
200	180	125	0,45
200	200	125	0,39
224	80	124	0,12
224	100	127	0,18
224	125	132	0,23
224	160	137	0,24
224	180	137	0,41
224	224	137	0,64
250	80	137	0,12
250	100	140	0,18
250	125	145	0,23
250	160	150	0,24
250	180	150	0,41
250	200	150	0,34
250	224	150	0,63
250	250	150	0,80

\* Hand made without radius.

## Order code

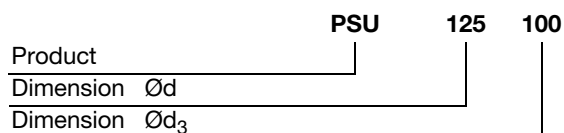

# T-piece

# TCU



## Dimensions

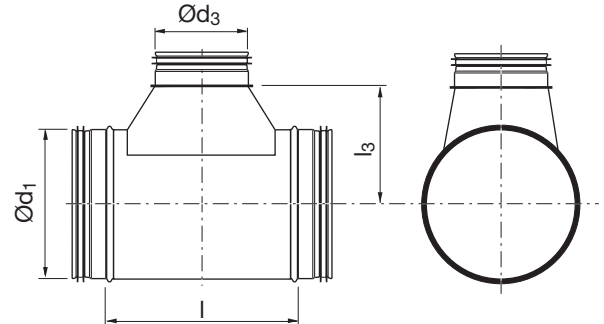

## Description

Centric T-piece with hand made T-piece TSTCU.  
Also available in other dimensions up to Ø400.

Ød <sub>1</sub> nom	Ød <sub>3</sub> nom	l mm	l <sub>3</sub> mm	m kg
100	125	240	95	0,56
100	160	280	100	0,68
125	160	280	115	0,77
125	180	300	115	0,85
125	200	335	130	1,01
160	180	335	145	1,21
160	200	335	145	1,21
160	250	385	145	1,52
180	200	335	155	1,32
180	224	360	155	1,41
180	250	385	155	1,58
200	224	360	165	1,50
200	250	385	165	1,68
224	200	385	180	1,94
224	250	385	180	1,94

## Order code

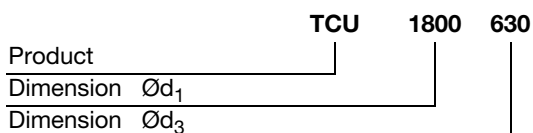

# T-piece

# TCPU



## Description

T-piece built with PSU saddle or a fully pressed top section.

Also available in other dimensions up to Ø400.

## Dimensions

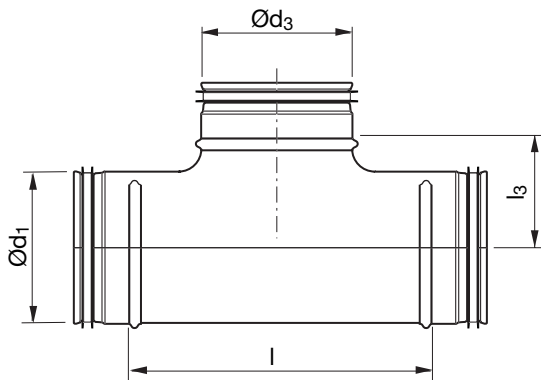

## Dimensions

Ød <sub>1</sub> nom	Ød <sub>3</sub> nom	l mm	l <sub>3</sub> mm	m kg
80	80	140	52	0,36
100	80	97	60	0,23
100	100	130	65	0,32
125	80	97	72	0,34
125	100	130	78	0,37
125	125	165	83	0,44
160	80	140	92	0,59
160	100	130	95	0,46
160	125	166	100	0,53
160	160	209	105	0,63
180	80	140	102	0,92
180	100	175	105	0,80
180	125	215	110	0,91
180	160	260	115	1,06
180	180	285	115	1,44
200	80	140	112	0,77
200	100	175	115	0,88
200	125	215	115	1,02
200	160	209	125	0,67
200	180	285	125	1,35
200	200	249	125	1,21
224	80	140	124	0,85
224	100	175	127	1,01
224	125	215	132	1,14
224	160	260	137	1,28
224	180	285	137	1,46
250	80	156	137	1,13
250	100	175	140	1,22
250	125	220	145	1,48
250	160	256	150	1,58
250	180	306	150	1,79
250	200	306	150	1,78
250	224	350	150	2,09
250	250	296	150	1,65

\* Hand made with saddle without radius.

## Order code

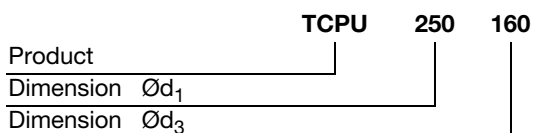

# T-piece

# TSTCU

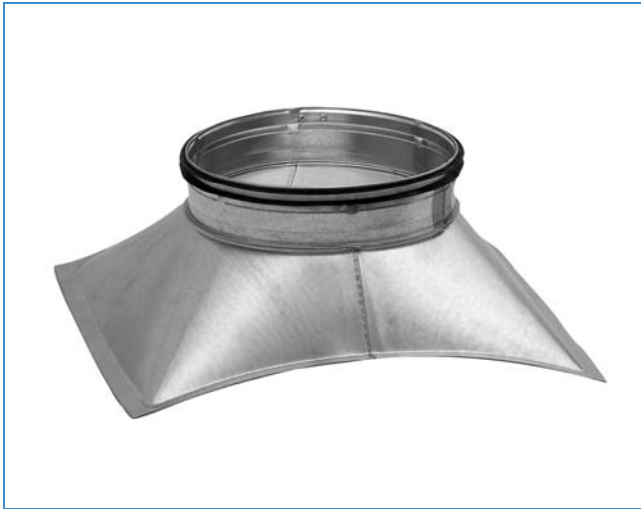

## Description

Hand made centric T-piece.

Also available in other dimensions up to Ø400.

## Dimensions

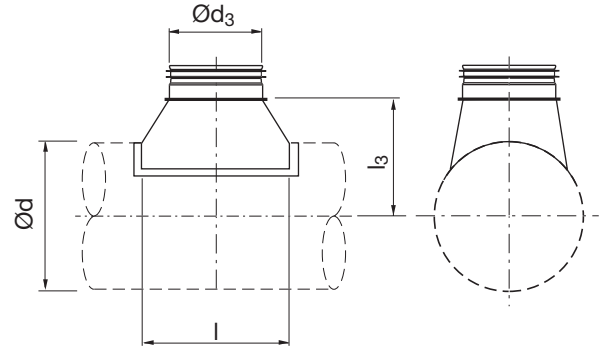

Ød nom	Ød <sub>3</sub> nom	l mm	l <sub>3</sub> mm	m kg
80	100	165	85	0,21
80	125	190	85	0,29
100	125	190	95	0,25
100	160	230	100	0,36
125	160	230	115	0,35
125	180	250	115	0,41
125	200	285	130	0,50
160	180	250	130	0,47
160	200	285	145	0,57
160	224	310	145	0,65
160	250	335	145	0,85
180	200	285	155	0,62
180	224	310	155	0,69
180	250	335	155	0,82
200	224	310	165	0,66
200	250	335	165	0,79
224	200	285	180	0,63
224	250	335	180	0,84

## Order code

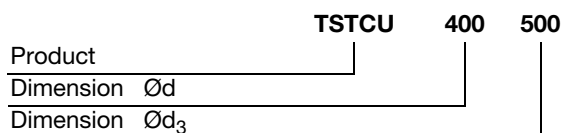

# Take-off

ILU



## Dimensions

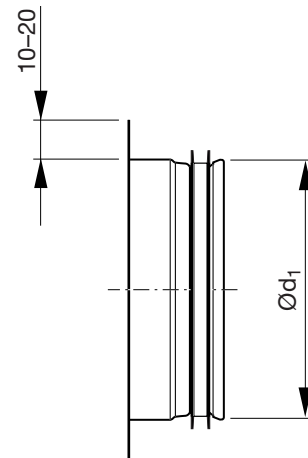

## Description

Take-off without radius.

Also available in other dimensions up to Ø400.

Ød <sub>1</sub> nom	m kg
80	0,07
100	0,08
112	0,09
125	0,11
140	0,12
150	0,12
160	0,16
180	0,15
200	0,17
224	0,23
250	0,33

## Order code

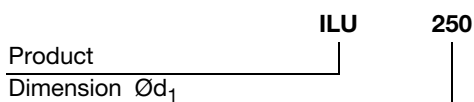

# Take-off

# ILRU



## Description

Take-off with radius.

Also available in other dimensions up to Ø400.

## Dimensions

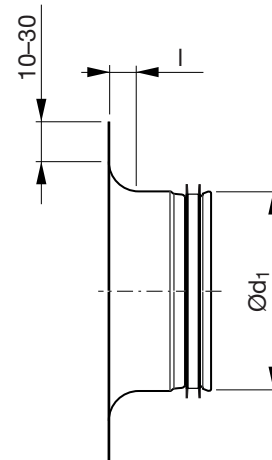

Ød <sub>1</sub> nom	l mm	m kg
80	12	0,10
100	15	0,11
125	20	0,14
160	25	0,19
180	25	0,30
200	25	0,26
224	25	0,46
250	25	0,57

## Order code

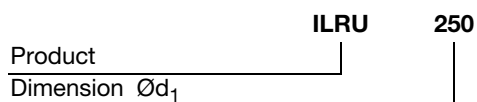

# Take-off

ILF



## Dimensions

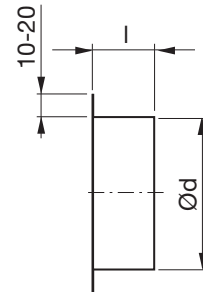

### Description

Take-off without radius. With female end – fits outside a Safe fitting.

Hasn't any Click function – hasn't any notches.

Also available in other dimensions up to Ø400.

Ød nom	l mm	m kg
100	45	0,06
125	45	0,08
160	45	0,16
180	45	0,19
200	45	0,21
224	45	0,26
250	65	0,31

### Order code

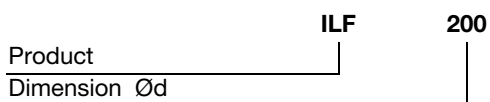



# Take-off with mesh

# ILRNU

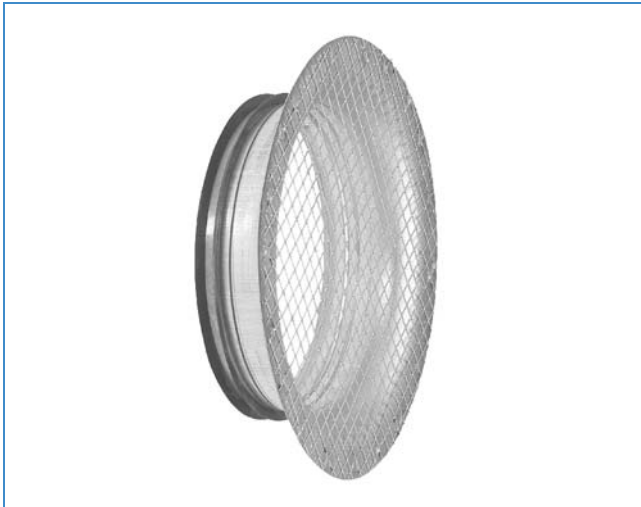

## Dimensions

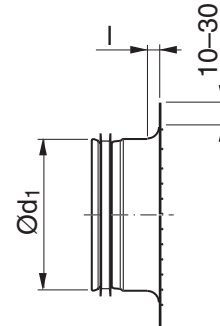

## Description

To terminate an inlet duct.

With radius.

Mesh size 10 × 10 mm

Also available in other dimensions up to Ø400.

Ød <sub>1</sub> nom	l mm	m kg
80	12	0,11
100	15	0,16
125	20	0,21
140	20	0,24
150	20	0,27
160	25	0,22
180	25	0,34
200	25	0,39
224	25	0,51
250	25	0,64

## Order code

Product	ILRNU	200
Dimension Ød <sub>1</sub>		



# Take-off with mesh

# ESNU



## Description

To terminate an inlet duct.

Mesh size 10 × 10 mm.

Also available in other dimensions up to Ø400.

## Dimensions

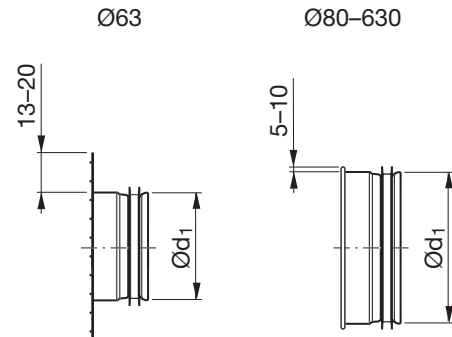

Ød <sub>1</sub> nom	m kg
80	0,08
100	0,10
125	0,13
160	0,17
180	0,21
200	0,25
224	0,31
250	0,38

## Order code

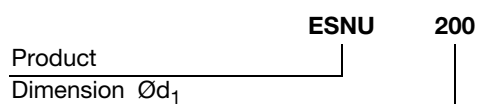

# Coupling

# NPU



## Dimensions

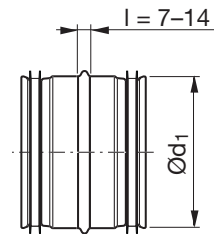

## Description

Coupling connector for joining circular ducts.

Also available in other dimensions up to Ø400.

Ød <sub>1</sub> nom	m kg
63	0,07
80	0,09
100	0,12
125	0,15
160	0,19
180	0,25
200	0,30
224	0,30
250	0,52

## Order code

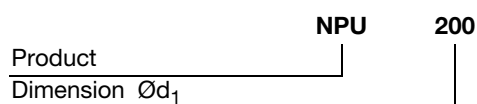

# Slide-in coupling

SNPU



## Dimensions

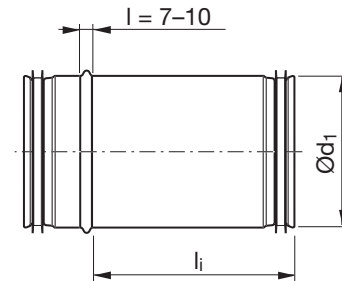

## Description

### Areas of use:

- To eliminate the accurate length cutting of ducts which the ordinary NPU connector sometimes requires when joining SR ducts. In this case the slide-in coupling shall be secured with screws or pop rivets.
- To make it possible to use a duct that is cut to a too short length – instead of having to cut a new duct to the correct length. In this case the slide-in coupling shall be secured with screws or pop rivets.
- To assist when joining two ducts which run towards each other. E.g. when building a system from two opposing directions. In this case the slide-in coupling shall be secured with screws or pop rivets.
- To assist when inserting or adding an other product into an existing system. E.g. the addition of a new piece of duct to replace a damaged part. In this case the slide-in coupling shall be secured with screws or pop rivets.
- To facilitate access when inspecting and/or cleaning a system – by simply sliding the coupling. The coupling acts as an access cap. Lindab do not recommend this use of larger dimensions than Ø315.

No Click function – has closed turned-over ends (at both ends).

Also available in other dimensions up to Ø400.

Ød <sub>1</sub> nom	L nom	l <sub>i</sub> mm	m kg
80	150	133	0,18
80	300	284	0,32
80	500	548	0,69
100	150	133	0,22
100	300	284	0,40
100	500	548	0,84
125	150	133	0,28
125	300	284	0,50
125	500	548	1,07
160	150	133	0,36
160	300	284	0,65
160	500	548	1,38
180	150	133	0,40
180	300	284	0,72
180	500	548	1,53
200	150	133	0,56
200	300	293	1,02
200	500	548	1,76
224	150	133	0,62
224	300	293	1,13
224	500	548	1,95
250	150	177	0,91
250	300	297	1,35
250	500	527	2,17

## Order code

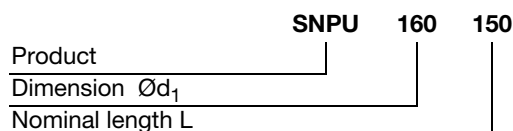

# Female coupling

MF



## Dimensions

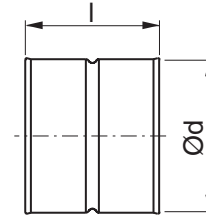

## Description

Female coupling for joining fittings.

Has normally not any Click function – hasn't any notches.

Ø 80–315 can upon order be delivered with click function – i.e. with notches.

Also available in other dimensions up to Ø400.

Ød nom	l mm	m kg
80 *	97	0,08
100 *	97	0,10
125 *	97	0,14
160 *	97	0,21
180	97	0,24
200 *	97	0,26
224	97	0,30
250 *	139	0,42

\* With turned-over edge

## Order code

Product	MF	200
Dimension Ød		



# Slide-in female coupling

# SMFU



## Dimensions

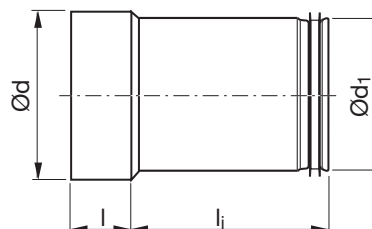

## Description

### Areas of use:

- To avoid the necessity of an exact length cutting of a duct when it is difficult to take a proper measure. E.g. the connection of a duct to a stub on an air supply terminal. In this case the slide-in coupling shall be secured with screws or pop rivets.
- To make it possible to use a duct that is cut to a too short length – instead of having to cut a new duct to the correct length. In this case the slide-in coupling shall be secured with screws or pop rivets.
- To eliminate or minimize the number of ordinary duct cuttings at building site – together with pre-cut ducts of shorter lengths. In this case the slide-in coupling shall be secured with screws or pop rivets.
- To assist when inserting or adding an other product into an existing system. E.g. the cutting-in of an extra silencer. In this case the slide-in coupling shall be secured with screws or pop rivets.
- To assist when removing an other product when cleaning a system. E.g. the removal of a damper with a obstructionable blade. Lindab do not recommend this use of larger dimensions than Ø315.
- To facilitate access when inspecting and/or cleaning a system – by simply sliding the coupling. The coupling acts as an access cap. Lindab do not recommend this use of larger dimensions than Ø315.
- To extend the distance between a T-piece and an access cap, e.g. EPFH or KCU, to get the cap outside any insulation. In this case the slide-in coupling shall be secured with screws or pop rivets only at its female end.

No Click function – has a closed turned-over end and hasn't any notches.

Also available in other dimensions up to Ø400.

Ød <sub>1</sub> nom	L nom	l mm	l <sub>i</sub> mm	m kg
80	150	40	127	0,16
80	300	40	288	0,30
80	500	40	552	0,65
100	150	40	127	0,20
100	300	40	288	0,38
100	500	40	552	0,81
125	150	40	127	0,25
125	300	40	288	0,47
125	500	40	552	1,01
160	150	40	127	0,31
160	300	40	288	0,60
160	500	40	552	1,29
180	150	40	127	0,35
180	300	40	288	0,68
180	500	40	552	1,45
200	150	40	127	0,49
200	300	40	297	0,96
200	500	40	552	1,67
224	150	40	127	0,55
224	300	40	297	1,08
224	500	40	552	1,87
250	150	60	192	0,90
250	300	60	302	1,28
250	500	60	537	2,10

\* With stiffening bead.

## Order code

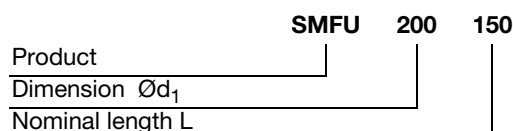

# End cap

EPF



## Dimensions

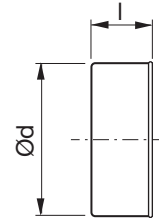

### Description

End cap, which fits outside a Safe fitting.

No Click function – no notches.

Also available in other dimensions up to Ø400.

Ød nom	l mm	m kg
80 *	48	0,07
100 *	48	0,11
125 *	48	0,14
160 *	48	0,17
180	48	0,24
200 *	46	0,21
224	46	0,35
250 *	68	0,50

\* With turned-over edge

### Order code

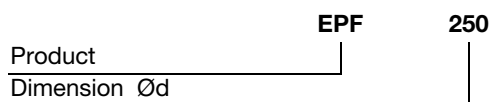

# End cap

ESU



## Dimensions

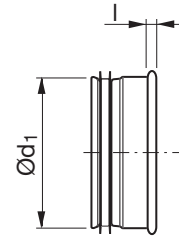

### Description

End cap, fits SR duct.  
Also available in other dimensions up to Ø400.

Ød <sub>1</sub> nom	l mm	m kg
80	10	0,08
100	10	0,12
125	10	0,14
160	10	0,24
180	10	0,28
200	10	0,32
224	10	0,40
250	10	0,37

### Order code

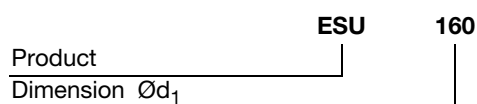



# Circular straight silencer

# SLU



## Dimensions

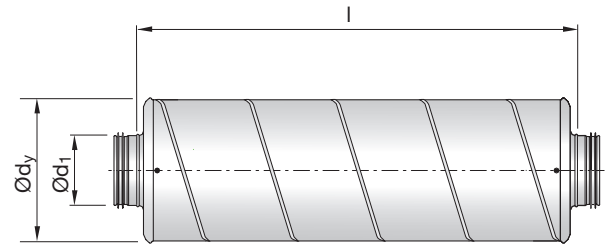

## Description

SLU 50 is a circular straight silencer with a connection diameter available between 63 - 400 mm.

Nominal insulation thickness 50 mm. Attenuation material is mineral wool. The SLU's are made of strong outer spiral seemed tube and an inner tube made of sheet steel with small openings to be able to withstand mechanical cleaning and at the same time not interfere with the insertion loss. The space between them is filled with mineral wool and a nonwoven cloth is inserted between inner tube and the attenuation material, to prevent fibers from the insulation getting into the duct system.

Tested according to ISO 7235 standard.

Special materials and sizes, please contact Lindab sales.

Ød <sub>1 nom</sub> mm	l <sub>nom</sub> mm	Attenuation in dB for centre frequency Hz								Ød <sub>y</sub> mm	l mm	m kg
		63	125	250	500	1k	2k	4k	8k			
80	300	1	5	8	15	25	25	21	15	190	300	2,0
80	600	2	8	14	28	49	50	47	24	190	600	3,0
80	900	3	10	21	40	50	50	50	34	190	900	5,0
80	1200	4	13	27	50	50	50	50	43	190	1200	7,0
100	300	1	5	7	15	25	25	21	13	210	360	2,0
100	600	1	7	12	25	43	48	35	20	210	660	3,0
100	900	2	10	17	34	50	50	49	28	210	960	5,0
100	1200	3	12	22	44	50	50	50	35	210	1260	7,0
125	300	0	4	5	13	23	20	16	11	235	365	3,0
125	600	1	5	10	22	39	37	26	16	235	665	4,0
125	900	1	7	14	30	50	50	37	21	235	965	7,0
125	1200	2	9	18	39	50	50	47	26	235	1265	9,0
160	300	0	3	5	11	22	16	11	7	270	370	3,0
160	600	1	4	8	19	37	28	17	11	270	670	6,0
160	900	1	5	12	27	50	39	24	14	270	970	8,0
160	1200	2	6	15	35	50	50	30	17	270	1270	10,0
200	300	0	2	4	9	19	11	7	5	310	385	4,0
200	600	1	3	8	15	28	19	12	8	310	685	7,0
200	900	2	4	11	21	37	28	16	10	310	985	10,0
200	1200	2	5	14	27	46	36	21	13	310	1285	12,0
250	600	1	2	6	14	26	14	8	7	365	600	9,0
250	900	1	3	9	19	38	19	11	9	365	900	12,0
250	1200	2	4	11	24	50	24	13	11	365	1200	15,0

## Order code

<b>Product</b>	SLU	aaa	bbbb	50
SLU				
<b>Connection dim. Ød<sub>1nom</sub></b>				
63 - 250 mm				
<b>Length in mm ( l<sub>nom</sub> )</b>				
300 - 1200 mm				
<b>Insulation thickness</b>				
50 mm				

Example: SLU -125- 600 - 50



# Low-built silencer

# LRCA



## Description

Straight silencer with circular connection and low installation height.

LRCA dimensions make it particularly suitable for installation above suspended ceilings or where space is otherwise limited.

Fulfills tightness class C.

Tested according to ISO 7235 standard.

Special materials and sizes, please contact Lindab sales.

## Dimensions

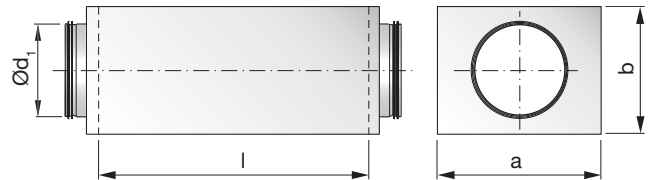

Ød <sub>1</sub> mm	l mm	a mm	b mm	Insertion loss [dB] for centre frequency [Hz]								m kg
				63	125	250	500	1k	2k	4k	8k	
100	500	210	158	8	12	12	23	44	45	30	18	3,2
100	1000	210	158	17	18	25	41	50	50	50	32	5,6
125	500	239	181	8	9	11	21	36	36	23	14	3,9
125	1000	239	181	17	14	21	38	50	50	45	23	6,9
160	500	275	218	6	7	10	18	28	24	13	10	4,4
160	1000	275	218	9	10	19	36	50	49	24	17	7,9
200	500	328	254	5	6	9	16	22	17	7	7	5,7
200	1000	328	254	11	13	15	30	46	36	14	12	10,1
250	500	390	308	5	4	8	16	19	13	6	6	7,2
250	1000	390	308	11	7	14	31	41	26	12	9	13,0

## Order code

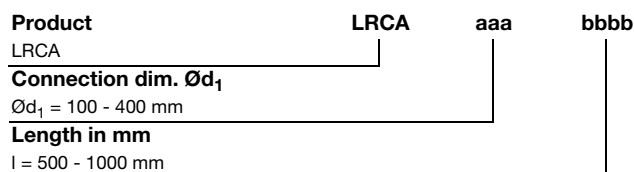

Example: LRCA - 125 - 1000



# Semiflexible double duct silencer

# SLFA 50



## Dimensions

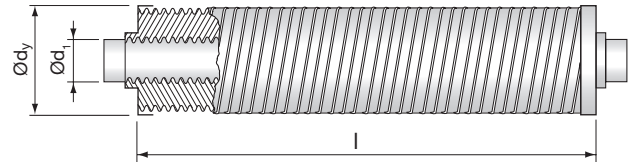

## Description

SLFA 50 is a flexible silencer that can be adapted to any installation situation. The bendability of the silencer allows adaptation to very confined spaces and difficult wiring. Silencers are made from 2-layer, flexible aluminium tubes of type SRF. The inner tube is micro-perforated and between the inner and outer tubes is a 50 mm thick attenuation material layer of glass wool. The attenuation material reduces the noise passing through the silencer. The ends of the silencer are covered with aluminium gables. The duct connections fits inside ducts. SLFA 50 comes in the dimensions Ø80-250 mm and 1000 mm in length. (Also available in lengths of 750, 1250, 1500 and 2000 mm). The silencers can withstand temperatures up to 200 °C.

Ød <sub>1</sub> nom mm	l mm	Attenuation in dB for centre frequency Hz								Ød <sub>y</sub> mm	m kg
		63	125	250	500	1k	2k	4k	8k		
80	750									190	
80	1000	3	13	19	30	47	58	33	28	190	1,10
80	1250									190	
80	1500									190	
80	2000									190	
100	750									210	
100	1000	2	11	16	28	46	58	36	36	210	1,30
100	1250									210	
100	1500									210	
100	2000									210	
125	750									235	
125	1000	1	7	13	24	41	45	29	28	235	1,70
125	1250									235	
125	1500									235	
125	2000									235	
160	750									260	
160	1000	1	5	10	21	39	30	20	18	260	1,90
160	1250									260	
160	1500									260	
160	2000									260	
200	750									310	
200	1000	3	4	9	16	32	22	15	15	310	2,40
200	1250									310	
200	1500									310	
200	2000									310	
250	750									365	
250	1000	2	4	8	16	33	15	11	12	365	3,00
250	1250									365	
250	1500									365	
250	2000									365	
315	750									410	
315	1000	2	3	6	12	25	11	8	11	410	3,40
315	1250									410	
315	1500									410	
315	2000									410	

## Order code

<b>Product</b>	SLFA	aaa	bbbb	50
SLFA				
<b>Connection dim. Ød<sub>1</sub> nom</b>	80 - 315 mm			
<b>Length in mm</b>	750 - 2000 mm			
<b>Insulation thickness</b>	50 mm			

Example: SLFA - 160 - 1250 - 50



# Silencer

# SLRS



## Description

Rectangular straight silencer from the Aerodim™ series. SLRS is built with the Aerodim™ silencer splitter SLRA.

The SLRA is manufactured with a frame of galvanized sheet and absorption material type Lindtec™. The splitter is available in a width of 200 mm. Silencer is equipped with flange profile RJFP or LS.

Due to the aerodynamic design, the SLRS has a low pressure loss and a low generation of flow noise. To calculate the silencer, you can use our IT-program lindQST or DIMsilencer, where splitter distance, length and height can be optimized for the best performance.

Tested according to ISO 7235 standard.

## Order code

<b>Product</b>	SLRS	200	bbb*	cccc	dddd	aaaa	bb
SLRS							
<b>Splitter width in mm</b>							
Max. 200 mm							
<b>Splitter distance in mm</b>							
Max. 100 mm							
<b>100</b>							
1200							
<b>900</b>							
1000							
<b>LS</b>							
Mln. - Max. 500 - 2500 mm							
<b>Connection type</b>							
e.g. LS							

Example: SLRS - 200 - 100 - 1200 - 900 - 1000 - LS

## Dimensions

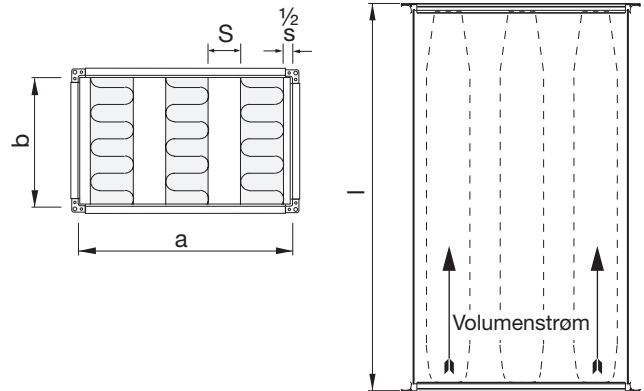

### Splitter distance S = 60

Length $l_{nom}$ mm	Attenuation in dB for centre frequency Hz								Pressure value $\xi$
	63	125	250	500	1k	2k	4k	8k	
750	4	9	18	26	35	32	22	16	8,9
1350	6	15	31	46	50	50	36	25	12,0
1500	7	16	34	50	50	50	39	27	12,9
1950	9	21	44	50	50	50	48	32	15,2
2550	11	26	50	50	50	50	50	37	18,5

### Splitter distance S = 80

Length $l_{nom}$ mm	Attenuation in dB for centre frequency Hz								Pressure value $\xi$
	63	125	250	500	1k	2k	4k	8k	
750	3	7	15	23	30	27	18	14	4,9
1350	5	12	26	40	50	48	30	21	6,5
1500	5	14	29	44	50	50	32	22	6,9
1950	7	18	38	50	50	50	40	26	8,1
2550	8	22	47	50	50	50	49	31	9,6

### Splitter distance S = 100

Length $l_{nom}$ mm	Attenuation in dB for centre frequency Hz								Pressure value $\xi$
	63	125	250	500	1k	2k	4k	8k	
750	3	6	13	20	26	22	15	11	2,8
1350	4	11	23	36	50	40	24	17	3,8
1500	5	12	26	40	50	44	27	18	4,0
1905	6	15	33	50	50	50	33	22	4,7
2550	7	19	43	50	50	50	40	26	5,6

### Splitter distance S = 120

Length $l_{nom}$ mm	Attenuation in dB for centre frequency Hz								Pressure value $\xi$
	63	125	250	500	1k	2k	4k	8k	
750	2	6	12	19	23	18	12	9	1,8
1350	4	10	21	33	45	33	20	14	2,4
1500	4	11	23	36	50	36	22	15	2,5
1950	5	14	30	47	50	47	27	18	3,0
2550	6	18	39	50	50	50	33	22	3,5



# Silencer

# SLRS

## Technical data

### Splitter distance S = 140

Length $l_{nom}$ mm	Attenuation in dB for centre frequency Hz								Pressure value $\xi$
	63	125	250	500	1k	2k	4k	8k	
750	2	5	11	17	20	15	10	8	1,1
1350	3	9	19	30	39	27	17	12	1,5
1500	4	10	22	34	44	30	18	12	1,7
1950	4	12	28	44	50	38	22	15	2,0
2550	5	16	36	50	50	49	27	18	2,4

NB. Max. attenuation specified is 50 dB.

Standard lengths (l) : 750, 1350, 1500, 1950, 2550. (shown in table above).

Standard heights (b): 300, 600, 900, 1200, 1800.

*(Other lengths and heights are available. See min. - max. dimensions in order code. Note that you can exceed the max. dimensions by building together several SLRA/SLRS. See the AeroDim installation instruction for more details).*

Special materials and sizes, please contact Lindab sales.

**The pressure loss**  $\Delta p$  in Pa can be calculated from the pressure value  $\xi$ :  $\Delta p = 0,6 \times v^2 \times \xi$ , where (v) is the velocity on the face area of the silencer.



# Silencer splitter

# SLRA

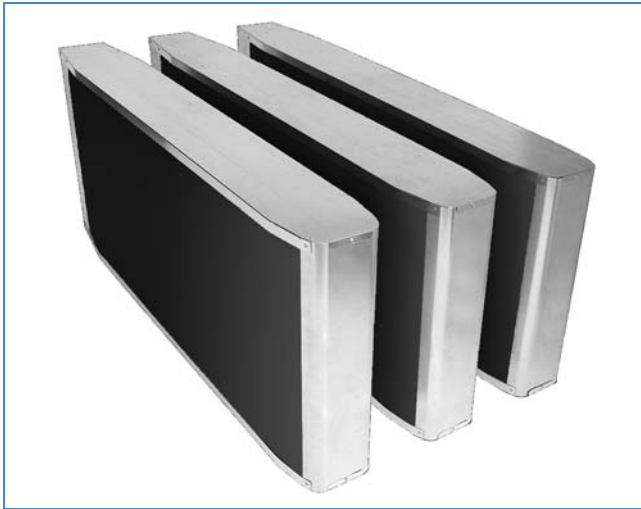

## Description

Aerodim-A is the basic element in the Aerodim™ silencer series. The SLRA is manufactured with a frame of galvanized sheet and absorption material type Lindtec™.

The SLRA is available in a width of 200 mm. The Aerodim-A is also available in other lengths and with other splitter distances than shown in the tables.

Special materials and sizes, please contact Lindab sales.

The Lindtec™ surface is easy to clean and prevents removal of fibres. Due to the aerodynamic design, the SLRA has a low pressure loss and a low generation of flow noise. To calculate the silencer, you can use our IT-program DIMsilencer, where splitter distance, length and height can be optimized for the best performance.

Tested according to ISO 7235 standard.

## Order code

<b>Product</b>	SLRA	aaaa	bbbb
SLRA			
<b>Height b i mm</b>			
Max. 1200 mm (in single SLRS*)			
<b>Length l<sub>nom</sub> i mm</b>			
Max. 2500 mm			

Example: SLRA - 600 - 1000

\* The max. hight of the splitter can be increased by building two splitters on top of each other. See the SLRA / SLRS installation instruction for more details.

## Dimensions

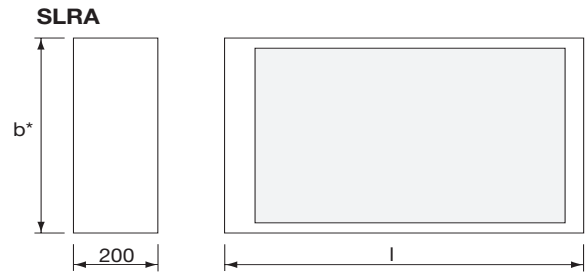

b\* = Manufactured height of splitter is b-5 mm, to fit into duct.

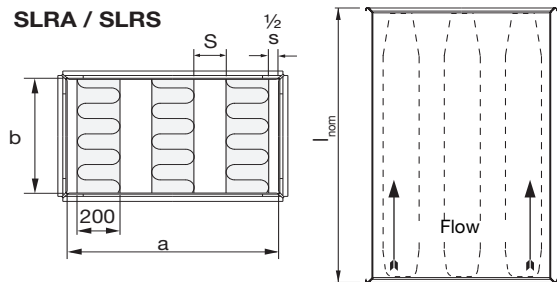

## Technical data

### Splitter distance S = 60 mm

Length l <sub>nom</sub> mm	Attenuation in dB for centre frequency Hz							Pressure value ξ	
	63	125	250	500	1k	2k	4k		8k
700	4	9	18	26	35	32	22	16	8,9
1300	6	15	31	46	50	50	36	25	12,0
1450	7	16	34	50	50	50	39	27	12,9
1900	9	21	44	50	50	50	48	32	15,2
2500	11	26	50	50	50	50	50	37	18,5

### Splitter distance S = 80 mm

Length l <sub>nom</sub> mm	Attenuation in dB for centre frequency Hz							Pressure value ξ	
	63	125	250	500	1k	2k	4k		8k
700	3	7	15	23	30	27	18	14	4,9
1300	5	12	26	40	50	48	30	21	6,5
1450	5	14	29	44	50	50	32	22	6,9
1900	7	18	38	50	50	50	40	26	8,1
2500	8	22	47	50	50	50	47	31	9,6

### Splitter distance S = 100 mm

Length l <sub>nom</sub> mm	Attenuation in dB for centre frequency Hz							Pressure value ξ	
	63	125	250	500	1k	2k	4k		8k
700	3	6	13	20	26	22	15	11	2,8
1300	4	11	23	36	50	40	24	17	3,8
1450	5	12	26	40	50	44	27	18	4,0
1900	6	15	33	50	50	50	33	22	4,7
2500	7	19	42	50	50	50	39	25	5,6



# Silencer splitter

# SLRA

## Technical data

### Splitter distance S = 120 mm

Length $l_{nom}$ mm	Attenuation in dB for centre frequency Hz								Pressure value $\xi$
	63	125	250	500	1k	2k	4k	8k	
700	2	6	12	19	23	18	12	9	1,8
1300	4	10	21	33	45	33	20	14	2,4
1450	4	11	23	36	50	36	22	15	2,5
1900	5	14	30	47	50	46	27	18	3,0
2500	6	17	38	50	50	50	32	21	3,5

### Splitter distance S = 140 mm

Length $l_{nom}$ mm	Attenuation in dB for centre frequency Hz								Pressure value $\xi$
	63	125	250	500	1k	2k	4k	8k	
700	2	5	11	17	20	15	10	8	1,1
1300	3	9	19	30	39	27	17	12	1,5
1450	4	10	22	34	44	30	18	12	1,7
1900	4	12	28	44	50	38	22	15	2,0
2500	5	15	35	50	50	47	27	17	2,4

NB. Max. attenuation specified is 50 dB.

The pressure loss  $\Delta p$  in Pa can be calculated from the pressure value  $\xi$ :  $\Delta p = 0,6 \times v^2 \times \xi$  where (v) is the velocity on the face area of the silencer.



# Collar pipe

RGN

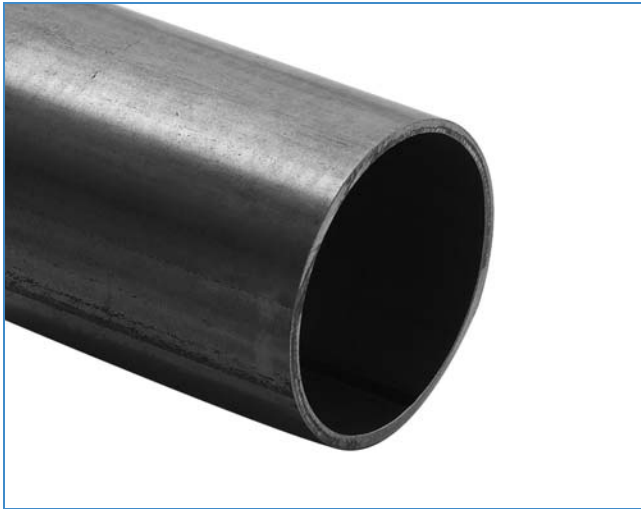

## Dimensions

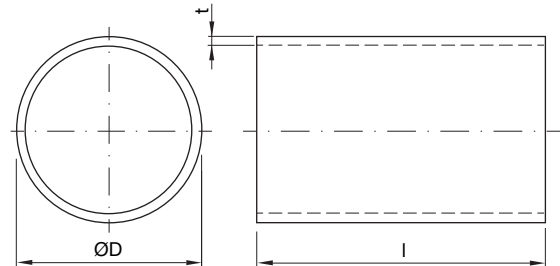

## Description

The RGN is lead through the decks and bulkheads to connect the ducts or fittings.

Also available with yellow primer or in aluminium.

Ød nom	ØD mm	l mm	t mm	m kg
80	88,9	125	4,05	1,10
80	88,9	200	4,05	1,80
80	88,9	900	4,05	8,10
100	114,3	125	6,30	2,10
100	114,3	200	6,30	3,10
100	114,3	900	6,30	16,0
125	139,7	125	6,30	2,60
125	139,7	200	6,30	4,20
125	139,7	900	6,30	20,0
160	177,8	125	8,80	4,60
160	177,8	200	8,80	7,30
160	177,8	900	8,80	34,2
180	193,7	125	5,60	3,20
180	193,7	200	5,60	5,20
180	193,7	900	5,60	25,2
200	219,1	125	8,80	5,70
200	219,1	200	8,80	9,10
200	219,1	900	8,80	42,6
224	241,0	125	8,00	5,80
224	241,0	200	8,00	9,20
224	241,0	900	8,00	41,4
250	267,0	125	8,80	7,00
250	267,0	200	8,80	11,2
250	267,0	900	8,80	50,4

## Order code

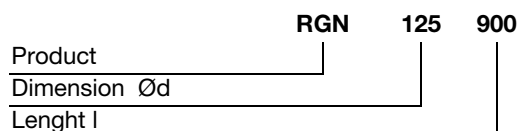



# Collar pipe

# RGIN

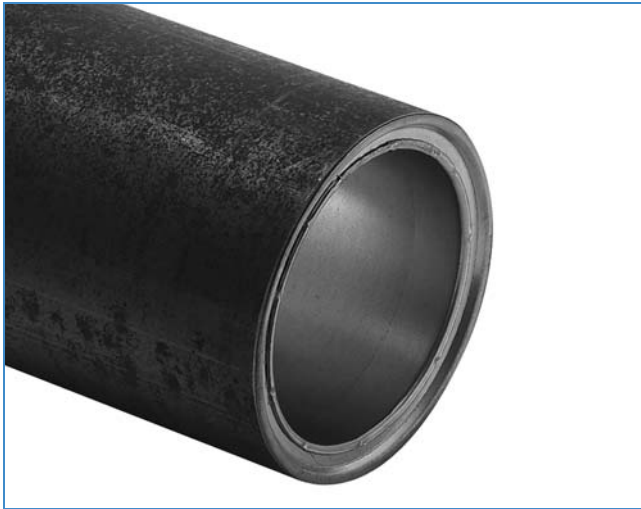

## Dimensions

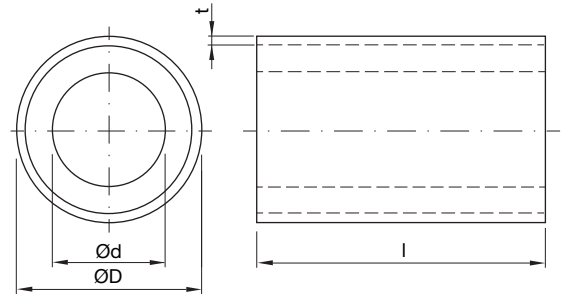

## Description

The RGIN is lead through the decks and bulkheads to connect the ducts or fittings, and is insulated with mineral wool. Also available with yellow primer or in aluminium.

Ød nom	ØD mm	l mm	t mm	m kg
80	114,3	125	3,60	1,30
80	114,3	200	3,60	2,00
80	114,3	900	3,60	9,00
100	139,7	125	6,30	2,90
100	139,7	200	6,30	4,60
100	139,7	900	6,30	21,5
125	159,0	125	4,50	2,60
125	159,0	200	4,50	4,10
125	159,0	900	4,50	19,5
160	193,7	125	5,60	3,60
160	193,7	200	5,60	5,80
160	193,7	900	5,60	27,2
180	219,1	125	4,50	3,40
180	219,1	200	4,50	5,40
180	219,1	900	4,50	25,7
200	244,5	125	6,30	5,20
200	244,5	200	6,30	8,30
200	244,5	900	6,30	39,0
224	267,0	125	6,30	5,60
224	267,0	200	6,30	9,00
224	267,0	900	6,30	40,5
250	298,5	125	8,80	8,85
250	298,5	200	8,80	14,2
250	298,5	900	8,80	64,0

## Order code

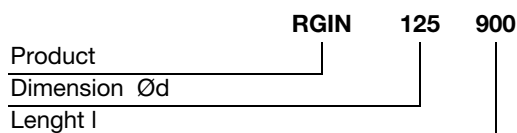

# Telescopic connector

# SKNPUK



## Dimensions

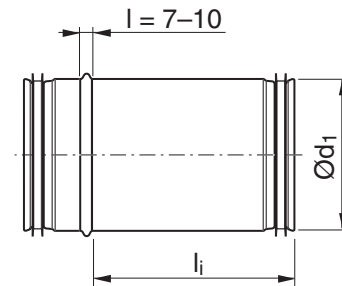

## Description

Telescopic connector, used with the collar pipes RGN or RGIN.

Ød <sub>1</sub> nom	l mm	m kg
80	208	0,10
100	208	0,10
125	208	0,10
160	208	0,10
180	208	0,10
200	208	0,10
224	208	0,10
250	182	0,10

## Order code

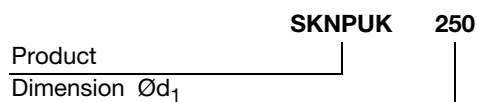

# Damper

# INDRU



## Dimensions

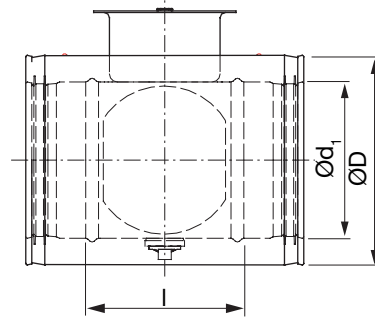

## Description

Manual regulation damper. The damper is double-jacketed and insulated with mineral wool and is supplied with Safe rubber seal on the inner dimension.

With stop bead to ensure correct installation.

Ød <sub>1</sub> nom	ØD mm	l mm	m* kg
80	112	100	0,62
100	132	100	0,74
125	157	100	0,95
160	192	100	1,09
180	200	100	1,30
200	232	100	1,45
224	260	100	2,02
250	280	100	2,46
280	315	100	2,73
300	355	100	2,94
315	355	100	3,18

\* = weight can vary ±10%.

## Order code

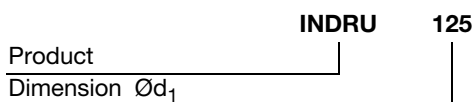

# Regulating damper

DRU



## Dimensions

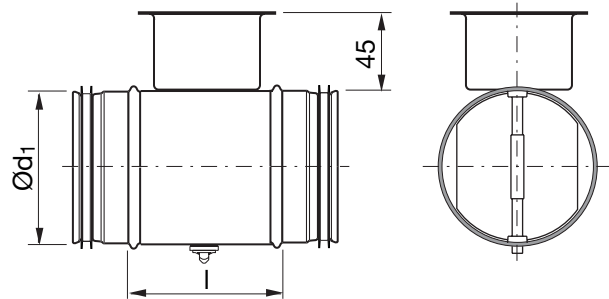

## Description

Has a turning, cut-off blade. The blade is stepless adjustable 0–90°. The damper admits an insulation thickness of approx. 50 mm.

The blade is designed to generate a minimum of noise. The noise is approx. the same as for a perforated blade. But the blade is less sensitive to clogging since it lacks perforations.

Setting the blade angle at the rim of the cup ( $\alpha$ )

$\alpha = 0^\circ$  = open blade

$\alpha = 90^\circ$  = closed blade

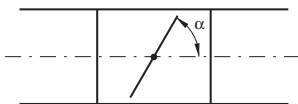

There is a separate assembly, measuring, balancing and maintenance instruction for this product.

Ø 80–1000 fulfills pressure class A in closed position.

The cup at Ø 80–630 can be complemented with the special insulation cup IK at insulation thicker than 50 mm.

Ød <sub>1</sub> nom	l mm	m kg	Sealing class past closed blade
80	100	0,34	0
100	100	0,40	0
125	100	0,46	0
160	100	0,65	0
180	100	0,69	0
200	100	0,80	0
224	100	0,90	0
250	100	1,28	0

## Order code

Product	DRU	125
Dimension Ød <sub>1</sub>		



# Damper

# INDSU



## Dimensions

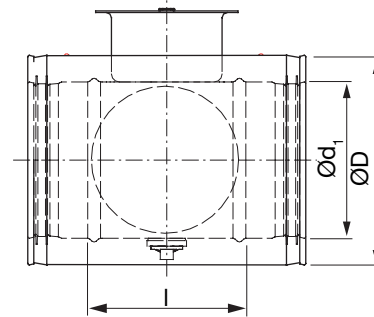

## Description

Manual closing damper, without sealing at the blade.  
 The damper is double-jacketed and insulated with mineral wool and is supplied with a rubber seal on the inner dimension.  
 With stop bead to ensure correct installation.

Ød <sub>1</sub> nom	ØD mm	l mm	m* kg
80	112	100	0,64
100	132	100	0,76
125	157	100	0,96
160	192	100	1,11
180	200	100	1,31
200	232	100	1,46
224	260	100	2,04
250	280	100	2,48
280	315	100	2,77
300	355	100	2,96
315	355	100	3,22

\* = weight can vary ±10%.

## Order code

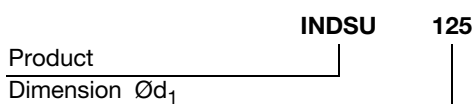

# Shut-off damper

DSU



## Dimensions

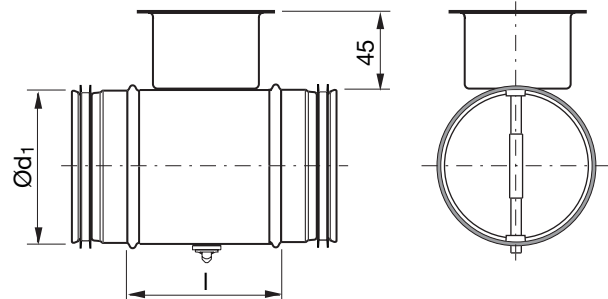

## Description

Has a turning, circular blade. The blade is stepless adjustable 0–90°. The damper is used when you have lower demands for shut-off capacity. The damper admits an insulation thickness of approx. 50 mm.

The damper can on occasions be used for regulation.

Setting the blade angle at the rim of the cup ( $\alpha$ )

$\alpha = 0^\circ$  = open blade

$\alpha = 90^\circ$  = closed blade

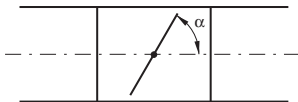

There is a separate assembly, measuring, balancing and maintenance instruction for this product.

Ø 63–1000 fullfills pressure class A in closed position.

The cup at Ø 80–630 can be complemented with the special insulation cup IK at insulation thicker than 50 mm.

Ød <sub>1</sub> nom	l mm	m kg	Sealing class past closed blade
80	100	0,35	0
100	100	0,40	0
125	100	0,49	0
160	100	0,67	0
180	100	0,73	0
200	100	0,86	0
224	100	1,10	0
250	100	1,31	0

## Order code

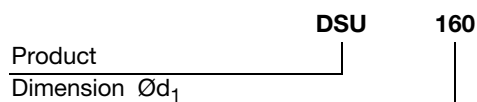

# Damper

# INDTU



## Dimensions

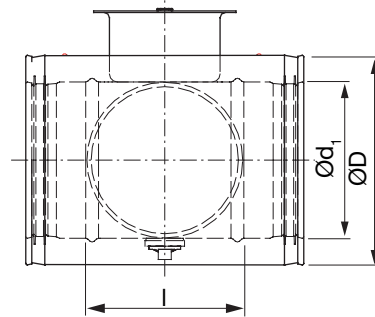

## Description

Insulated tight close damper. The damper is double-jacketed and insulated with mineral wool and is supplied with Safe rubber seal on the inner dimension.

With stop bead to ensure correct installation.

Ød <sub>1</sub> nom	ØD mm	l mm	m* kg
80	112	100	0,72
100	132	100	0,87
125	157	100	1,04
160	192	100	1,30
180	200	100	1,42
200	232	100	1,72
224	260	100	2,19
250	280	100	2,68
280	315	100	3,00
300	355	100	3,25
315	355	100	3,50

\* = weight can vary ±10%.

## Order code

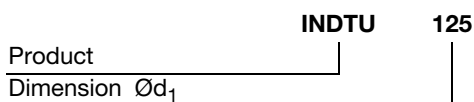

# Shut-off damper

DTU



## Dimensions

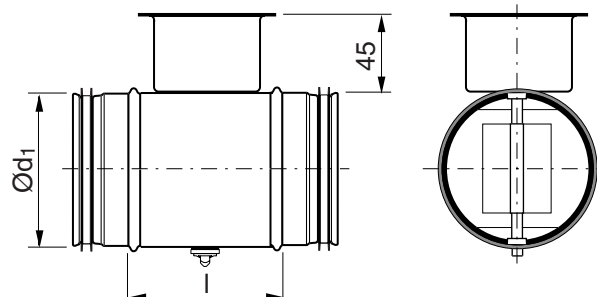

## Description

Has a turning circular blade with an EPDM-rubber seal which tightens against the inside of the damper when closed. The blade can be adjusted in a 090 angle.

The cup at 80630 can be complemented with the special insulation cup IK at insulation thicker than 50 mm.

The damper can be used for regulating at rare occasions.

There is a separate assembly, measuring, balancing and maintenance instruction for this product.

Ø 80–315 fullfills pressure class C in closed position.

Ø 355–630 fullfills pressure class B in closed position.

Ø 710–1000 fullfills pressure class A in closed position.

## Motorizing

The torque needed for the motorizing is given in the adjacent table.

Ø 710–1000 is not possible to motorize on site.

Ød <sub>1</sub> nom	l mm	M Nm	m kg	Sealing class past closed blade
80	100	2,0	0,30	4
100	100	2,0	0,38	4
125	100	2,0	0,53	4
160	100	2,0	0,74	4
180	100	2,0	0,82	4
200	100	2,0	1,04	4
224	100	3,0	1,27	4
250	100	3,0	1,52	4

## Order code

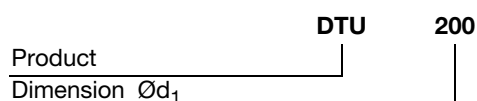



# Damper

# INDTMU



## Dimensions

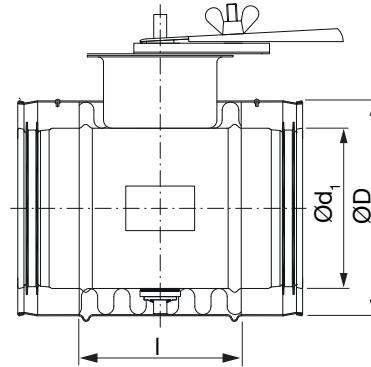

## Description

INDTMU are tight-closing shut-off dampers. The damper is double-jacketed, insulated with mineral wool and supplied with Safe rubber seal on the inner dimension.

With stop bead to ensure correct installation.

Equipped with a handle and a locking mechanism for step-less adjustment of 0–90°.

Ø 80–315 fullfills pressure class C in closed position.

Ød <sub>1</sub> nom	ØD mm	l mm	m* kg
80	112	100	1,2
100	132	100	1,4
125	157	100	1,5
160	192	100	1,7
180	200	100	1,9
200	232	100	2,1
224	260	100	2,5
250	280	100	3,1
280	315	100	3,4
300	355	100	3,7
315	355	100	4,0

\* = weight can vary ±10%.

## Order code

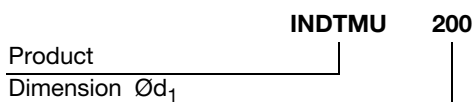

# Damper

# INDOSU



## Dimensions

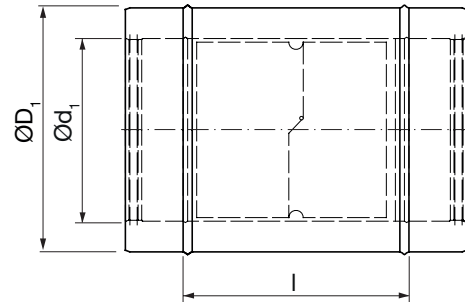

## Description

The non-return damper is double-jacketed and insulated with mineral wool, and is supplied with Safe rubber seal in the inner dimension.  
With stop bead to ensure correct installation.

Ød <sub>1</sub> nom	ØD <sub>1</sub> mm	l mm	m* kg
80	112	100	0,36
100	132	100	0,81
125	157	100	1,02
160	192	100	1,25
180	200	100	1,34
200	232	100	1,59
224	260	100	1,82
250	280	100	3,09
280	315	100	3,40
300	355	100	3,60
315	355	100	3,98

\* = weight can vary ±10%.

## Order code

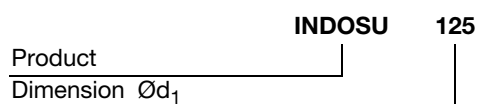

# Damper, non-return

# DOSU



## Dimensions

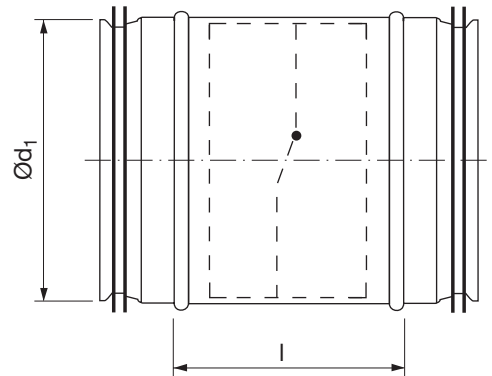

## Description

One-way dampers are used to prevent natural back-flows. It can be mounted both vertically and horizontally (note the arrow marking) and are designed to be installed near the outlet.

At horizontal installation please make sure that the sticker (UP) is at the top.

Ød <sub>1</sub> nom	l mm	m kg
80	130	0,40
100	130	0,50
125	130	0,60
160	130	0,80
200	130	1,00
250	245	1,90

## Order code

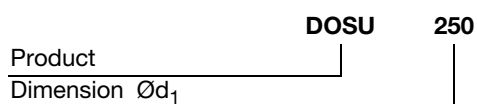

# Damper, non-return

# RKUIN



## Description

The non-return valve is double-jacketed and insulated with mineral wool, and is supplied with Safe rubber seal in the inner dimension.

## Dimensions

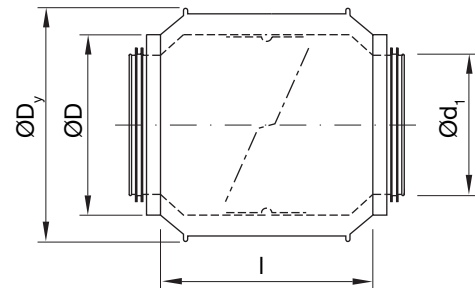

Ød <sub>1</sub> nom	ØD nom	ØD <sub>y</sub> nom	l mm	m kg
80	112	140	135	1,10
100	132	165	150	1,40
125	157	200	150	1,85
160	192	240	160	2,35
180	200	240	280	3,00
200	232	290	215	3,65
224	250	290	370	4,30
250	280	365	270	5,50

## Order code

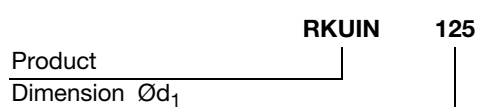

# Damper with flow meter

# DIRU



## Dimensions

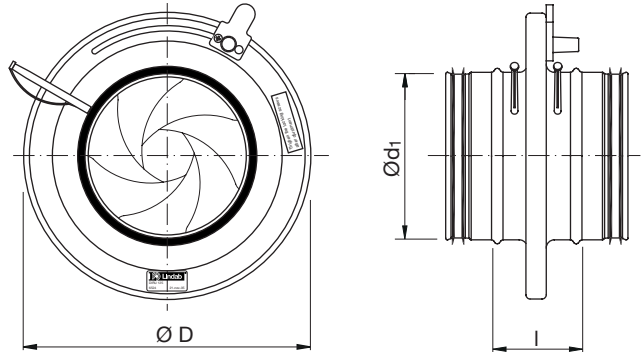

## Description

The damper DIRU with flow meter offers measurement of the air flow. DIRU has the following characteristics: low noise level, centric flow, fixed measurement nozzles for accurate flow measurement and is equipped with regulating facilities that can be fully opened, which means that you do not need cleaning covers. It fulfils tightness class C.

The dimension graph is to be used to determine the pressure drop over the damper with flow meter and to give information regarding the sound effect level at different settings. When balancing the system the balancing graph should be used.

There is a separate assembly, measuring, balancing and maintenance instruction for dampers with flow meter.

The damper blades forms a measuring flange which allows flow measuring. By measuring the pressure difference between the measure nozzles, you can through the equation on the damper derive the flow  $q$  [l/s]. The setting value of the damper and the correction factor (k-factor) is the same number which means that you do not have to read a graph in order to get the k-factor from a setting value.

The air flow is regulated with a handle.

Ø 80–250 fullfills pressure class A in closed position.

### Material

The damper is made of hot-dip galvanized sheet steel.

### Installation

Consider required straight distance after or before disturbance, as mentioned on the card attached to the measurement nozzles, to obtain accurate flow measurement.

### Cleaning

By fully open the damper, one get access to the duct. Do not forget to readjust the damper after cleaning.

Ød <sub>1</sub> nom	ØD mm	l mm	m kg
100	163	54	0,80
125	210	63	1,20
160	230	60	1,40
200	285	62	2,00
250	333	62	2,60

## Order code

Product	DIRU	160
Dimension Ød <sub>1</sub>		



# Damper with flow meter

# FMDU



## Dimensions

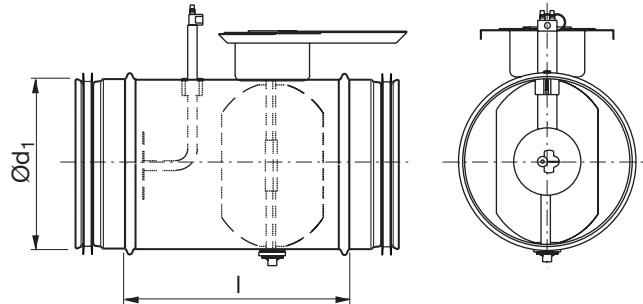

## Description

### Applications

The meter is suitable both for setting up and for continuous flow measurement. It is intended for permanent installation and must therefore be specified at the design stage.

There is a separate assembly, measuring, balancing and maintenance instruction for this product.

Ø 80–250 fullfills tightness class 0 and pressure class A .

### Design

The meter consists of a regulating shutter and a centrally located measurement plate. Each measurement nozzle has a removable plastic plug which prevents dirt from entering. It also eliminates air leakage when measurement is not done.

The unit permits insulation of up to 50 mm thickness to be installed without concealing the measurement nipples or the label plate.

The plate can be rotated for best legibility, irrespective of the way the unit is installed and can easily be removed, to be located away from the unit. The cup around the damper knob allows insulation up to 50 mm thick to be used. If thicker insulation is needed, add the special insulation cup IK.

### Advantages

- Short installation length.
- Suitable for use with insulation.

Ød <sub>1</sub> nom	l mm	m kg
80	165	0,66
100	165	0,76
125	165	0,88
160	165	1,08
200	230	1,44
250	275	2,10

## Order code



# Constant flow damper

# DAU



## Dimensions

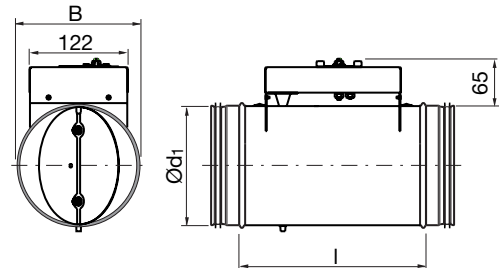

## Description

### Constant flow damper with manual setting of one flow

DAU is a constant flow damper, which facilitates balancing of ventilation systems and gives correct flow from the start. The unit compensates e.g. connection and disconnection of system parts, clogging of filters and ducts, thermal lift forces, wind effects, window opening etc. Ø 80–315 fullfills pressure class A in closed position. Fulfils tightness class C.

There is a separate assembly, measuring, balancing and maintenance instruction for this product.

## Technical data

### Flow setting

The flow is set by loosening the center nut and via the knob turning the scale arrow so it points at the wanted flow on the scale. Then the center nut is tightened.

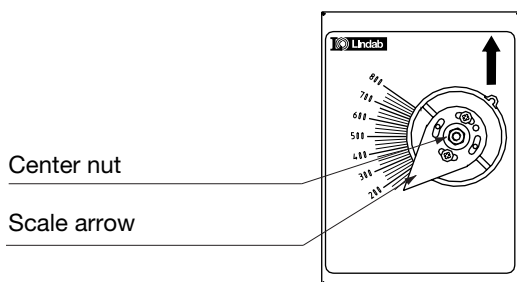

## Ordering example



Ød <sub>1</sub> nom	l mm	B mm	m kg	Tightness class across closed blade
80	246	122	1,35	0
100	246	122	1,40	0
125	246	135	1,65	0
160	246	170	1,85	0
200	246	210	2,26	0
250	284	260	3,35	0

DAU is available with an 45 mm external insulation and an outer sheet metal shell for lower sound radiation to the surroundings. Is then called DALU.

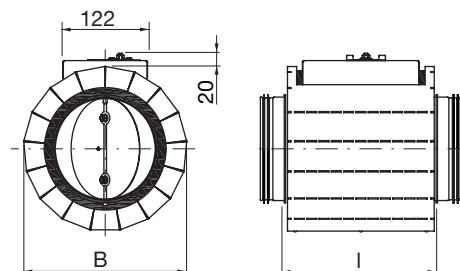

Ød <sub>1</sub> nom	l mm	B mm	m kg	Tightness class across closed blade
80	246	170	2,35	0
100	246	190	2,50	0
125	246	215	2,90	0
160	246	250	3,45	0
200	246	290	4,06	0
250	284	340	6,05	0



# Constant flow damper

# DA2EU



## Dimensions

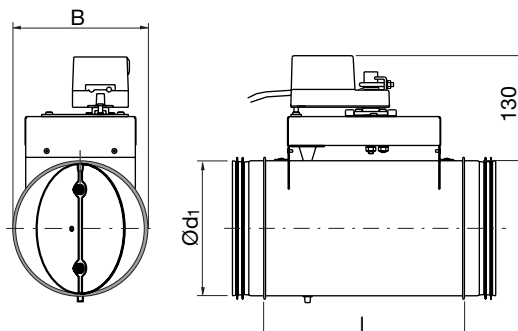

## Description

### Constant flow damper with electric motor for switching between two flows

DA2EU is a constant flow damper, which facilitates balancing of ventilation systems and gives correct flow from the start.

The unit compensates e.g. connection and disconnection of system parts, clogging of filters and ducts, thermal lift forces, wind effects, window opening etc.

The motors shall be completed with a switch. The switch can in turn be controlled either manually with timer, with on/off-thermostat, with attendance transmitter or similar.

Ø 80–315 fullfills pressure class A in closed position.

Fulfils tightness class C.

There is a separate assembly, measuring, balancing and maintenance instruction for this product.

Ød <sub>1</sub> nom	l mm	B mm	m kg	Tightness class across closed blade
80	246	122	1,95	0
100	246	122	2,00	0
125	246	135	2,25	0
160	246	170	2,45	0
200	246	210	2,86	0
250	284	260	3,95	0

## Order code

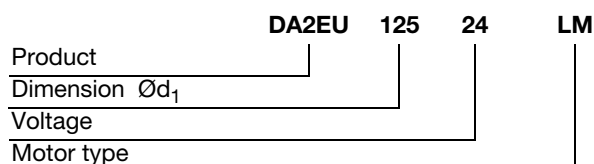



# Constant flow damper

# DAVU



## Dimensions

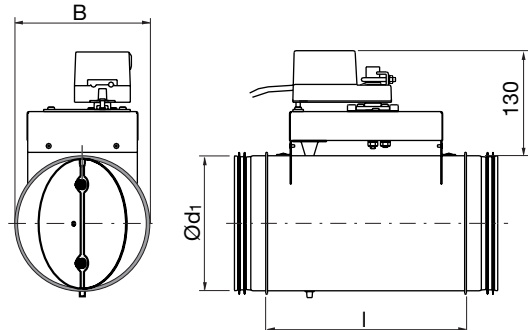

## Description

### Constant flow damper with electric motor for continuous setting of one flow

DAVU is a constant flow damper, which facilitates balancing of ventilation systems and gives correct flow from the start. The unit compensates e.g. connection and disconnection of system parts, clogging of filters and ducts, thermal lift forces, wind effects, window opening etc. The motor shall be completed with control signal transmitter e.g. an external potentiometer or a proportionally regulating thermostat. Ø 80–315 fullfills pressure class A in closed position. Fulfils tightness class C. There is a separate assembly, measuring, balancing and maintenance instruction for this product.

Ød <sub>1</sub> nom	l mm	B mm	m kg	Tightness class across closed blade
80	246	122	1,95	0
100	246	122	2,00	0
125	246	135	2,25	0
160	246	170	2,45	0
200	246	210	2,86	0
250	284	260	3,95	0

## Order code

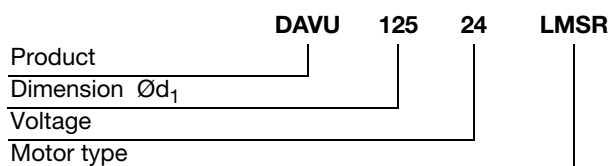

# Circular diffuser

# HPBDC



## Dimensions

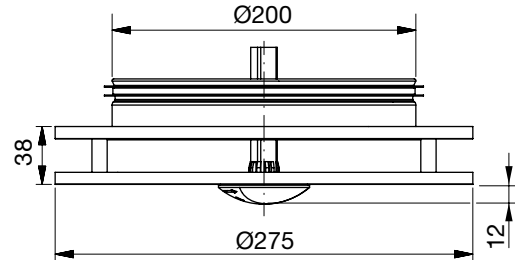

## Description

HPBDC is a circular diffuser with a closed front plate and a regulating handle suitable for adjusting the damper in a HPB cabin unit. It is compact diffuser suitable for the horizontal supply of cooled air

- Discrete design
- Handle for adjusting damper
- High Impulse
- Insulated face plate

## Maintenance

Faceplate can be removed to enable cleaning of internal parts or to gain access to the box. The visible parts of the diffuser can be wiped with a damp cloth.

## Accessories

Blending profiles (set) for 1, 2 and 3-way supply air.

## Materials and finish

Material:	Galvanised steel
Std. finish:	Powder-coated
Std. colour:	White RAL 9010, gloss 30
Insulation:	Non-flammable melamine foam plastic

Flow adjustment Handle: White plastic.

The diffuser is available in other colours and materials.

Please contact Lindab's sales department for further information.

## Order code

Product	HPBDC	200
Size		



# Cabin unit

# HPB



## Description

HPB is a Cabin Unit specially designed for use in high pressure systems where high flexibility has to be combined with minimum installation space. An internal scale makes it possible to preadjust the flow in order to minimize commissioning costs and document settings.

The matching diffuser HPBDC allows the user to adjust the flow within a preadjusted range.

- Adjustable damper with scale for required flowlevel-setting.
- Low noise level even at pressure above 1000 Pa.
- Flow range from 50 to 350 m<sup>3</sup>/h.
- Easy mounting with prefitted brackets.
- Excellent air distribution.
- Diffuser and inlet take off fitted with Lindab Safe rubber gasket for perfect tightness and low noise generation.
- User adjustable flow within the min./max. flow range.
- Adjustable mounting of diffuser for perfect fitting in ceiling.
- Low weight.

## Maintenance

Faceplate can be removed without tools to enable cleaning of internal parts or to gain access to the box. The visible parts of the diffuser can be wiped with a damp cloth. Box can be opened for cleaning.

Diffuser for CabinUnit is ordered separately.

## Order code

Product	HPB	100
Size		

## Dimensions

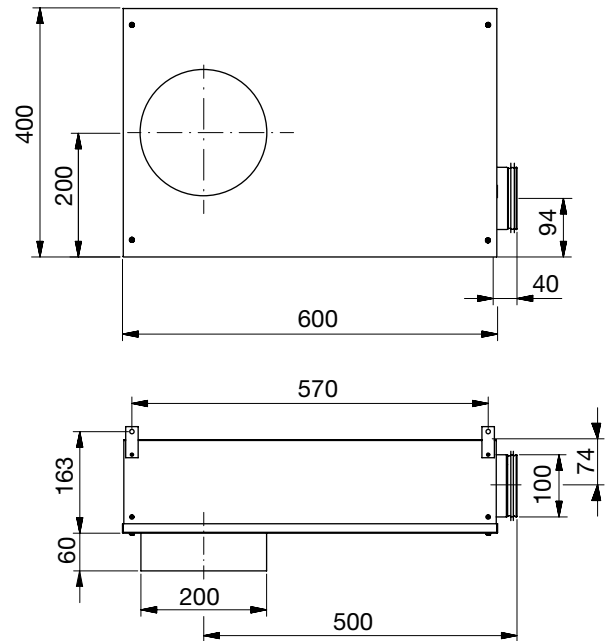

## Options

- Electrical heating element. 230V AC with selectable effects of 250, 500 or 1000 Watt.
- Integrated thermostat with selectable operating temperature between 30-110° C.
- Manuel safety switch cuts off electricity if the temperature exceeds 113° C
- Non-combustible mineral wool insulation
- External room thermostat
- Motorized flow adjustment within min and max. flow-level

## Materials and finish

Material: Galvanised steel.

Insulation: Non-flammable melamine foam plastic.

Please contact Lindab sales department for further information



# Perforated square diffuser

# PKAN



## Dimensions

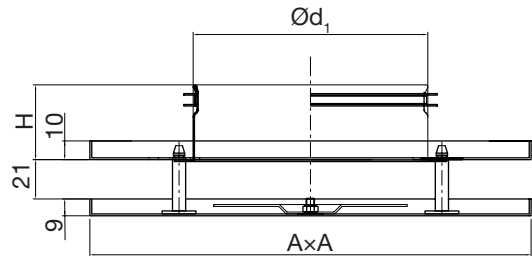

Ød <sub>1</sub> nom	AxA mm	H mm
125	235	40
160	295	40
200	395	40
250	495	60

## Description

PKAN is a square diffuser with perforated face plate. PKAN can be used for both supply and exhaust air. PKAN is suitable for the horizontal supply of cooled air and can be equipped with accessories of various types in order to achieve optimum function. Installing a PKAN diffuser in a plenum box type MBA can help to achieve a stable airflow to the diffuser as well as realise the potential for individual adjustment.

- Suitable for both supply and exhaust.
- Suitable for the horizontal supply of cooled air.

## Materials and finish:

Standard material: Galvanised steel "G"  
(Available in stainless steel  
AISI-304 "S")

Standard finish: Powder coated

Standard colour: White RAL 9010, gloss 30

The diffuser is available in other colours. Please contact Lindab's sales department for further information.

## Order code

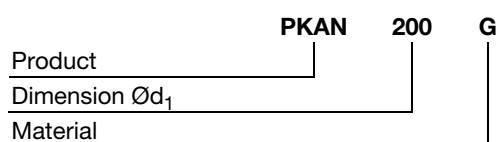

# Perforated circular diffuser

# PCAN



## Dimensions

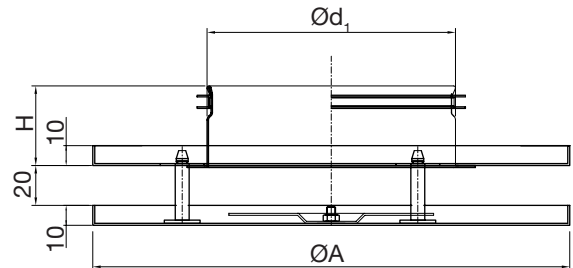

Ød <sub>1</sub> nom	ØA mm	H mm
100	240	40
125	240	40
160	300	40
200	360	40
250	460	60

## Description

PCAN is a circular diffuser with perforated face plate. PCAN can be used for both supply and exhaust air. PCAN is suitable for the horizontal supply of cooled air and can be equipped with accessories of various types in order to achieve optimum function. Installing a PCAN diffuser in a plenum box type MBA can help to achieve a stable airflow to the diffuser as well as realise the potential for individual adjustment.

- Suitable for both supply and exhaust.
- Suitable for the horizontal supply of cooled air.

## Materials and finish:

Standard material: Galvanised steel "G"  
(Available in stainless steel  
AISI-304 "S")

Standard finish: Powder coated

Standard colour: White RAL 9010, gloss 30

The diffuser is available in other colours. Please contact Lindab's sales department for further information.

## Order code

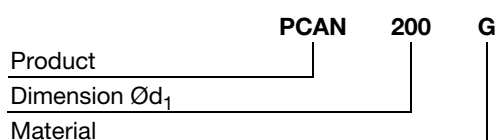

# Plain square diffuser

LKAN



## Dimensions

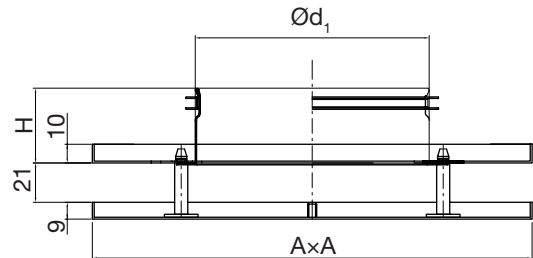

Ød <sub>1</sub> nom	AxA mm	H mm
125	235	40
160	295	40
200	395	40
250	495	60

## Description

LKAN is a square diffuser with an unperforated face plate. LKAN can be used for both supply and exhaust air. LKAN is suitable for the horizontal supply of cooled air and can be equipped with accessories of various types in order to achieve optimum function. Installing a LKAN diffuser in a plenum box type MBA can help to achieve a stable airflow to the diffuser as well as realise the potential for individual adjustment.

- Suitable for both supply and exhaust.
- Suitable for the horizontal supply of cooled air.

## Materials and finish:

Standard material: Galvanised steel "G"  
(Available in stainless steel  
AISI-304 "S")

Standard finish: Powder coated

Standard colour: White RAL 9010, gloss 30

The diffuser is available in other colours. Please contact Lindab's sales department for further information.

## Order code

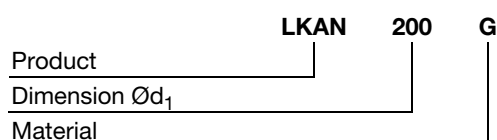

# Plain circular diffuser

# LCAN



## Dimensions

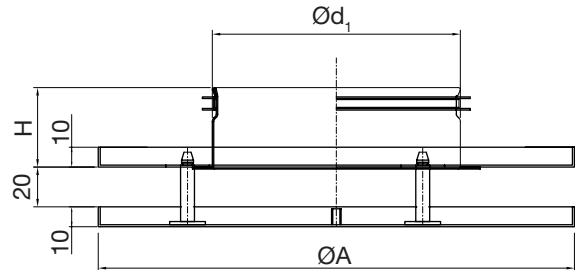

Ød <sub>1</sub> nom	ØA mm	H mm
100	240	40
125	240	40
160	300	40
200	360	40
250	460	60

## Description

LCAN is a circular diffuser with an unperforated face plate. LCAN can be used for both supply and exhaust air. LCAN is suitable for the horizontal supply of cooled air and can be equipped with accessories of various types in order to achieve optimum function. Installing a LCAN diffuser in a plenum box type MBA can help to achieve a stable airflow to the diffuser as well as realise the potential for individual adjustment.

- Suitable for both supply and exhaust.
- Suitable for the horizontal supply of cooled air.

## Materials and finish:

Standard material: Galvanised steel "G"  
(Available in stainless steel  
AISI-304 "S")

Standard finish: Powder coated

Standard colour: White RAL 9010, gloss 30

The diffuser is available in other colours. Please contact Lindab's sales department for further information.

## Order code

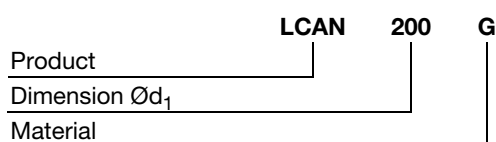

# Perforated diffuser

# PC6



## Description

PC6 is a circular perforated diffuser that can be used for both supply air and exhaust. The diffuser is suitable for the horizontal supply of cooled air. The diffuser can also be used for low impulse and is therefore useful for the supply of replacement air in environments with high rates of air exchange. Installing this diffuser in a plenum box type MBB can help to achieve a stable flow of air to the diffuser as well as realise the potential for individual adjustment.

- Suitable for both supply and exhaust air
- Discrete design
- Can be used for low impulse supply air

## Order code

<b>Product</b>	PC6	a	bbb
<b>Type</b>			
PC6			
<b>Functional use</b>			
S = Supply air			
E = Exhaust			
L = Low-impulse			
<b>Connection dim.</b>			
Ø125-315			

Example: PC6-S-200

## Dimensions

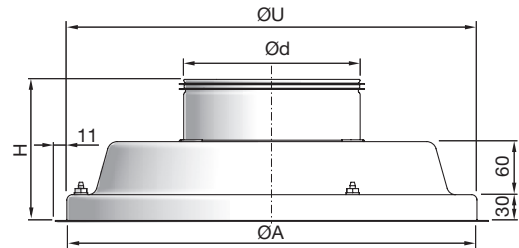

PC6 Ød mm	ØA mm	H mm	ØU* mm	m kg
125	360	140	370	3.90
160	460	140	470	5.30
200	460	140	470	5.40
250	540	140	550	7.40

\* ØU = ceiling grid opening

## PC6-S



## Materials and finish

Material: Galvanised steel  
 Standard finish: Powder-coated  
 Standard colour: RAL 9003 Gloss 30

The diffuser is available in other colours. Please contact Lindab's sales department for further information.





# Perforated diffuser

# PC7



## Description

PC7 is a circular diffuser with perforated face plate and integrated swirl insert. The diffuser is suitable for the horizontal supply of very cold air. The integrated swirl insert ensures optimum distribution and high induction. Installing this diffuser in a plenum box type MBB can help to achieve a stable flow of air to the diffuser as well as realise the potential for individual adjustment.

- High induction
- Discrete design
- Suitable for cooling at very low temperatures

## Dimensions

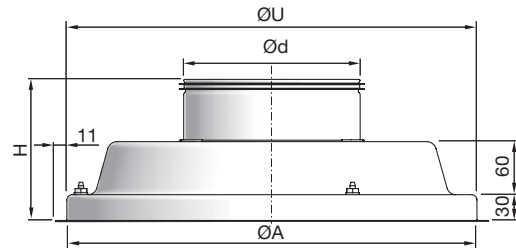

PC7 Ød mm	ØA mm	H mm	ØU* mm	m kg
160	460	140	470	5.30
200	460	140	470	5.40
250	540	140	550	7.40
315	540	140	550	8.10

\* ØU = ceiling grid opening

## PC7-S



## Order code

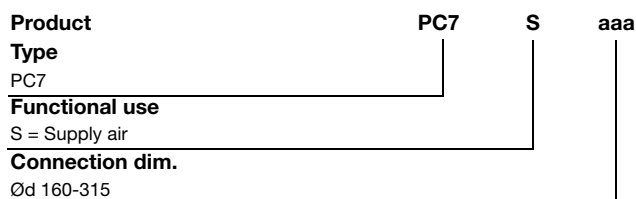

Example: PC7-S-200

## Materials and finish

Material: Galvanised steel  
 Standard finish: Powder-coated  
 Standard colour: RAL 9003 Gloss 30

The diffuser is available in other colours. Please contact Lindab's sales department for further information.



# Swirl diffuser

# RC14



## Description

RC14 is a circular swirl diffuser with fixed bars. The diffuser can be used for both supply air and exhaust. The swirl pattern ensures high induction and a large dynamic range, and is therefore ideal for the horizontal supply of very cold air. Installing this diffuser in a plenum box type MBB can help to achieve a stable flow of air to the diffuser as well as realise the potential for individual adjustment.

- Large dynamic range
- High induction
- Suitable for cooling at very low temperatures
- Can be used for both supply and exhaust air.

## Order code

<b>Product</b>	<b>RC14</b>	<b>a</b>	<b>bbb</b>
<b>Type</b>			
RC14			
<b>Functional use</b>			
S = Supply air			
E = Exhaust			
<b>Connection dim.</b>			
Ød 160-315			

Example: RC14-S-250

## Dimensions

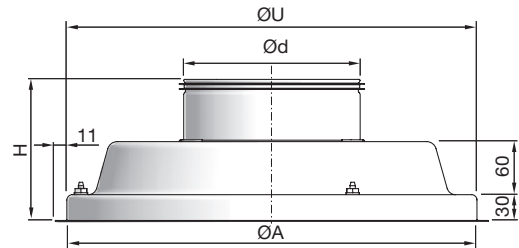

RC14 Ød	ØA	H	ØU*	m
mm	mm	mm	mm	kg
160	360	140	370	5.30
200	360	140	370	5.40
250	460	140	470	7.40

## RC14



## Materials and finish

Material:	Galvanised steel
Standard finish:	Powder-coated
Standard colour:	RAL 9003 Gloss 30

The diffuser is available in other colours. Please contact Lindab's sales department for further information.



# Swirl diffuser

# RC15



## Description

RC15 is a circular swirl diffuser with adjustable bars. The diffuser can be used for both supply and exhaust air. The swirl pattern ensures high induction and a large dynamic range, and is therefore ideal for the horizontal supply of very cold air. The diffuser can also be set to a vertical supply air pattern, enabling supply of heated air. Installing this diffuser in a plenum box type MBB can help to achieve a stable flow of air to the diffuser as well as realise the potential for individual adjustment.

- Large dynamic range
- High induction
- Suitable for cooling at very low temperatures
- Horizontal or vertical supply air pattern
- Can be used for both supply air and exhaust

## Order code

<b>Product</b>	RC15	a	bbb
<b>Type</b>			
RC15			
<b>Functional use</b>			
S = Supply air			
E = Exhaust ()			
<b>Connection dim.</b>			
Ød 160-315			

Example: RC15-S-160

## Dimensions

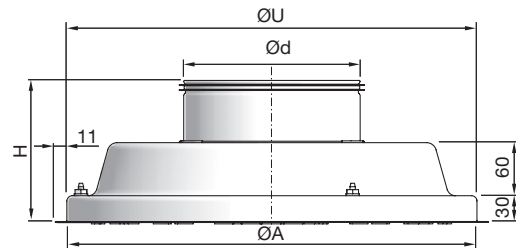

RC15 Ød mm	ØA mm	H mm	ØU* mm	m kg
160	360	140	370	5.30
200	360	140	370	5.40
250	460	140	470	7.40

\* ØU = ceiling grid opening

## Bar setting

### Horizontal

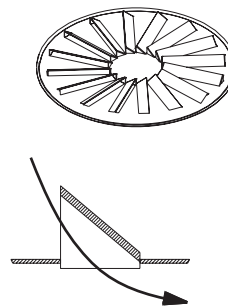

### RC15-S



### Vertical

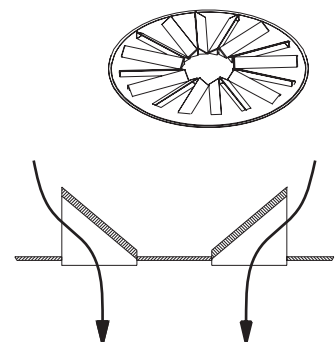

### RC15-E

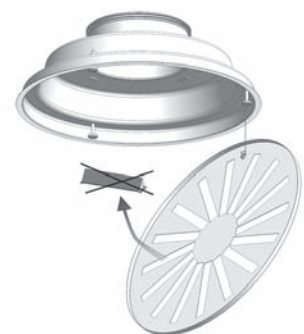

## Materials and finish

Material:	Galvanised steel
Standard finish:	Powder-coated
Standard colour:	RAL 9003 Gloss 30
Bars (Only RC15-S):	Black ABS plastic

The diffuser is available in other colours. Please contact Lindab's sales department for further information.



# Nozzle diffuser

# NC19



## Description

NC19 is a circular diffuser with individually adjustable nozzles. The diffuser is suitable for the horizontal supply of cooled air, where great flexibility in the dispersal pattern is required. The diffuser can also be set to a vertical supply air pattern, enabling supply of heated air. Installing this diffuser in a plenum box type MBB can help to achieve a stable flow of air to the diffuser as well as realise the potential for individual adjustment.

- Adjustable dispersal patterns
- No pressure change for different dispersal patterns
- Suitable for horizontal or vertical supply air patterns

## Order code

<b>Product</b>	<b>NC19</b>	<b>-</b>	<b>S</b>	<b>-</b>	<b>aaa</b>
<b>Type</b>	NC19				
<b>Functional use</b>			S = Supply air		
<b>Connection dim.</b>					Ød 125-315

Example: NC19-S-200

## Dimensions

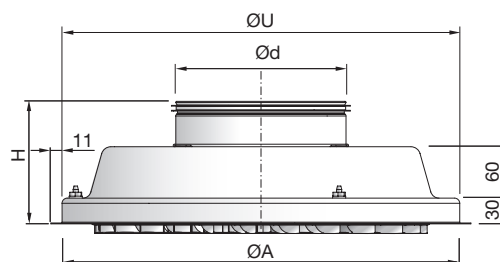

NC19 Ød	ØA	H	ØU*	m
mm	mm	mm	mm	kg
125	360	140	370	3.90
160	460	140	470	5.30
200	460	140	470	5.40
250	540	140	550	7.40

\* ØU = Ceiling grid opening



## Materials and finish

Material:	Galvanised steel
Standard finish:	Powder-coated
Standard colour:	RAL 9003, Gloss 30
Nozzles:	White ABS plastic

The diffuser is available in other colours. Please contact Lindab's sales department for further information.



# Versio

# PS1



PS1 with grille box type V

## Description

PS1 is a square perforated diffuser. PS1 can be used for both supply and exhaust air. PS1 is suitable for the horizontal supply of cooled air. PS1 can also be used for low impulse and is therefore useful for the supply of replacement air in environments with high rates of air exchange.

- Suitable for both supply and exhaust air
- The possibility of 1-2-3-way dispersal
- Can be used for low impulse
- Unique magnetic suspension of face plate

## Order code

<b>Product</b>	PS	a	b	c	d	eee	f
<b>Type</b>	PS						
<b>Design</b>	1 - 2 - 3 - 4						
<b>Box type</b>	V - H - R						
<b>Functional use</b>	S = Supply air E = Exhaust L = Low-impulse						
<b>Damper</b>	0 = ( : H, V) 1 = ( : H, R) 2 = ( : H)						
<b>Connection dim.</b>	Ø200-315 ( : V) Ø160-315 ( : H) 200x100 - 500x100 ( : R)						
<b>Ceiling system</b>	1 - 14						

Example: PS-1-V-S-0-200-1



PS1 with plenum box type H

## Dimensions

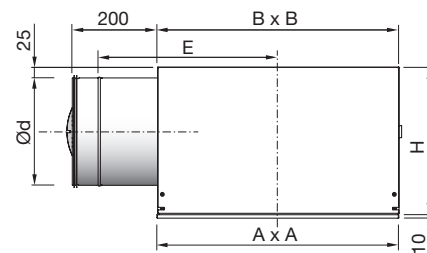

PS1-H	A	B	H	E	m	
Ød	Pattern	mm	mm	mm	mm	kg
160	400	**-	380	250	350	5,9
200	500	**-	460	290	390	8.50
250	600	**-	560	340	420	12.3
315	600	**-	560	405	420	13.1

\* Face plate dimension A x A depends on ceiling system. See "Ceiling adjustment" for detailed dimensions. For further details on plenum box - see "Plenum boxes".

## Maintenance

The face plate can be removed to enable cleaning of internal parts or to gain access to the duct or box. The visible parts of the diffuser can be wiped with a damp cloth.

## Materials and finish

### Grille box/plenum box:

Material: Galvanised steel

### Face plate:

Material: Galvanised steel  
Standard finish: Powder-coated  
Standard colour: RAL 9003, gloss 30

The diffuser is available in other colours. Please contact Lindab's sales department for further information.



# Versio

# PS8



PS8 with grille box type V

## Description

PS8 is a square perforated diffuser with swirl insert. PS8 fits naturally into the ceiling and maintains the excellent technical properties of swirl diffusers. The swirl pattern ensures high induction and a large dynamic range, and is therefore ideal for the horizontal supply of very cold air.

- Discrete appearance
- Large dynamic range
- High induction
- Ideal for the supply of very cold air

## Order code

<b>Product</b>	PS	a	b	S	d	eee	f
<b>Type</b>	PS						
<b>Design</b>	8 - 9 - 10 - 11						
<b>Box type</b>	V - H - R						
<b>Functional use</b>	S = Supply air						
<b>Damper</b>	0 = ( : H, V) 1 = ( : H, R) 2 = ( : H)						
<b>Connection dim.</b>	Ø160-315 ( : V) Ø125-315 ( : H) 200x100 - 500x100 ( : R)						
<b>Ceiling system</b>	1 - 14						

Example: PS-8-V-S-0-200-1



PS8 with plenum box type H

## Dimensions

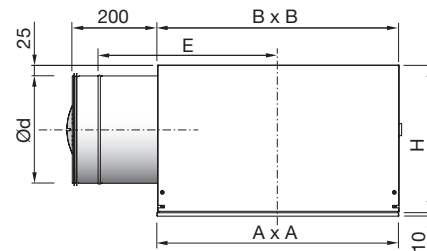

PS8-H	A	B	H	E	m
Ød	Pattern	mm	mm	mm	kg
125	300	**-	380	215	5.9
160	400	**-	380	250	5.9
200	500	**-	460	290	8.5
250	600	**-	560	340	12.3

\* Face plate dimension depends on ceiling system. See "Ceiling adjustment" for detailed dimensions. For further details on plenum box - see "Plenum boxes".

## Maintenance

The face plate can be removed to enable cleaning of internal parts or to gain access to the duct or box. The visible parts of the diffuser can be wiped with a damp cloth.

## Materials and finish

### Grille box/plenum box:

Material: Galvanised steel

### Face plate:

Material: Galvanised steel  
Standard finish: Powder-coated  
Standard colour: RAL 9003, gloss 30

The diffuser is available in other colours. Please contact Lindabs sales department for further information.



# Versio

# RS14



RS14 with grille box type V

## Description

RS14 is a square swirl diffuser with fixed bars. RS14 can be used for both supply and exhaust air. The swirl pattern ensures high induction and a large dynamic range. It is therefore ideal for the horizontal supply of very cold air.

- Large dynamic range
- High induction
- Suitable for cooling at very low temperatures
- Can be used for both supply air and exhaust
- Unique magnetic suspension of face plate

## Order code

<b>Product</b>	RS	14	b	c	d	eee	f
<b>Type</b>	RS						
<b>Design</b>	14						
<b>Box type</b>	V - H - R						
<b>Functional use</b>	S = Supply air E = Exhaust						
<b>Damper</b>	0 = ( : H, V) 1 = ( : H, R) 2 = ( : H)						
<b>Connection dim.</b>	Ø160-315 ( : V) Ø125-315 ( : H) 200x100 - 500x100 ( : R)						
<b>Ceiling system</b>	1 - 14						

Example: RS-14-V-S-0-200-1



RS14 with plenum box type H

## Dimensions

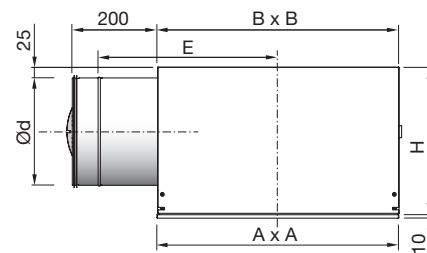

RS14-H	Ød	Pattern	A mm	B mm	H mm	E mm	m kg
	125	400	**-	380	215	350	5.9
	160	400	**-	380	250	350	5.9
	200	500	**-	460	290	390	8.5
	250	600	**-	560	340	420	12.3

\* Face plate dimension A x A depends on ceiling system. See "Ceiling adjustment" for detailed dimensions. For further details on plenum box - see "Plenum boxes".

## Maintenance

The face plate can be removed to enable cleaning of internal parts or to gain access to the duct or box. The visible parts of the diffuser can be wiped with a damp cloth.

## Materials and finish

### Grille box/plenum box:

Material: Galvanised steel

### Face plate:

Material: Galvanised steel  
Standard finish: Powder-coated  
Standard colour: RAL 9003, gloss 30

The diffuser is available in other colours. Please contact Lindab's sales department for further information.



# Versio

# RS15



RS15 with grille box type V

## Description

RS15 is a square swirl diffuser with adjustable bars that can be used for both supply and exhaust air. The swirl pattern ensures high induction and a large dynamic range. It is therefore ideal for the horizontal supply of very cold air. The diffuser can also be set to a vertical supply air pattern, enabling supply of heated air. The diffuser is supplied as standard with inward swirl. For exhaust, the diffuser is supplied as standard without bars

- Large dynamic range
- High induction
- Ideal for the supply of very cold air
- Adjustable for horizontal or vertical supply air pattern
- Can be used for both supply air and exhaust

## Order code

<b>Product</b>	RS	15	b	c	d	eee	f
<b>Type</b>	RS						
<b>Design</b>	15						
<b>Box type</b>	V - H - R						
<b>Functional use</b>	S = Supply air E = Exhaust						
<b>Damper</b>	0 = ( : H, V) 1 = ( : H, R) 2 = ( : H)						
<b>Connection dim.</b>	Ø200-315 ( : V) Ø160-315 ( : H) 300x100 - 500x100 ( : R)						
<b>Ceiling system</b>	1 - 14						

Example: RS15-V-S-0-200-1



RS15 with plenum box type H

## Dimensions

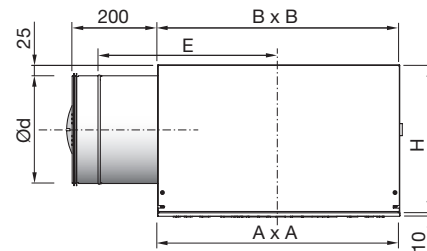

RS15-H	A	B	H	E	m	
Ød	Pattern	mm	mm	mm	kg	
160	400	**-	380	250	350	5.9
200	500	**-	460	290	390	8.5
250	600	**-	560	340	420	12.3

\* Face plate dimension A x A depends on ceiling system. See "Ceiling adjustment" for detailed dimensions. For further details on plenum box - see "Plenum boxes".

## Maintenance

The face plate can be removed to enable cleaning of internal parts or to gain access to the duct or box. The visible parts of the diffuser can be wiped with a damp cloth.

## Materials and finish

### Grille box/plenum box:

Material: Galvanised steel

### Face plate:

Material: Galvanised steel  
 Bars: Black ABS-plastic  
 Standard finish: Powder-coated  
 Standard colour: RAL 9003, gloss 30

The diffuser is available in other colours. Please contact Lindab's sales department for further information.





# Linear diffuser

# MTL

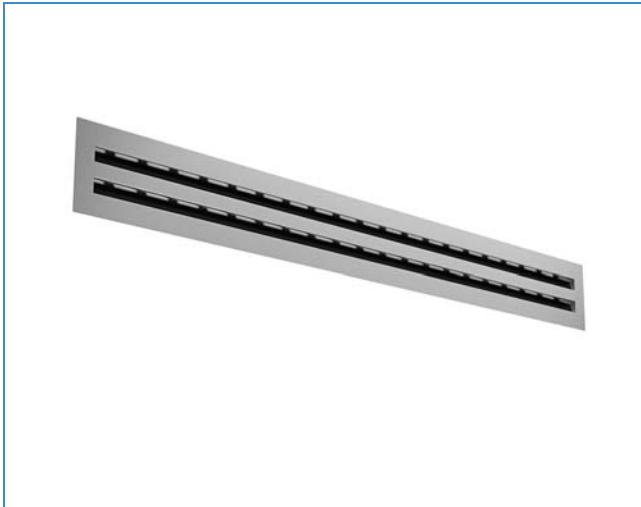

## Description

MTL is a rectangular linear diffuser in aluminium. MTL is suitable for both supply and exhaust air. MTL is equipped with air guide baffles, making it possible to use MTL for horizontal supply air. The horizontal dispersal pattern can be easily changed without the use of tools by turning the air guide baffle. The air guide baffle must be removed for vertical supply air.

MTL can be supplied in two versions, 15 mm or 19 mm, depending on capacity requirements or aesthetic considerations. MTL can be installed with plenum box STB/STU in order to achieve an even flow and individual adjustment. MTL is normally supplied in lengths up to max. 2 m, but can be supplied on request up to 5 m. MTZ-1 is a 90° joint, when an aesthetically pleasing corner is required.

- Discrete appearance
- Used for both supply air and exhaust
- Horizontal and vertical supply air.

## Maintenance

MTL can be removed to enable cleaning of internal parts or to gain access to the duct or box. The visible parts of the diffuser can be wiped with a damp cloth.

## Order code

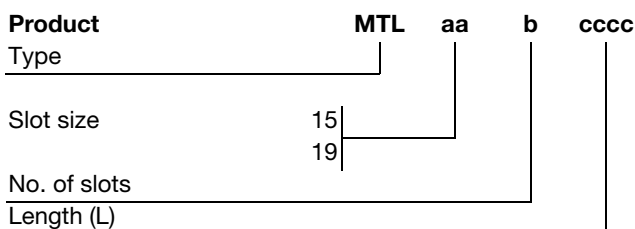

## Dimensions

MTL-15-2

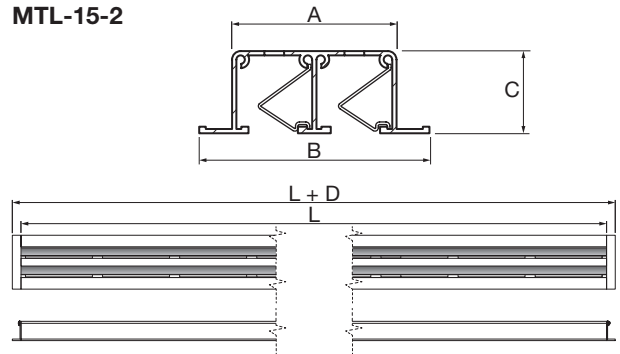

MTL-19-2

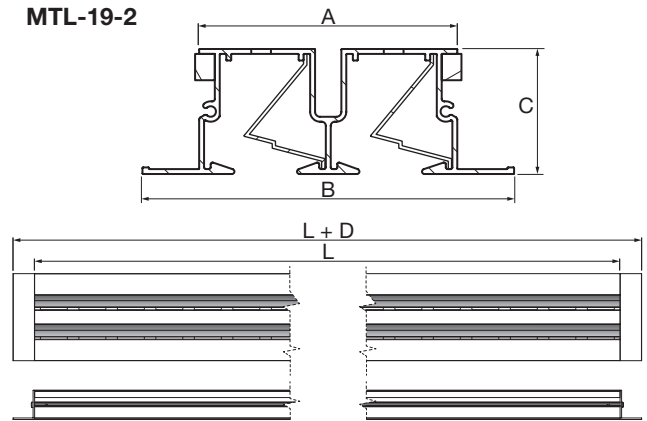

Both ends are equipped with flanges.

Slot width: 15 mm

No. of slots	A mm	B mm	C mm	D mm
1	25	45	25	30
2	50	70	25	30
3	75	95	25	30
4	100	120	25	30

Cutout: A + 10 mm x L + 10 mm

Slot width: 19 mm

No. of slots	A mm	B mm	C mm	D mm
1	40	75	38	56
2	79	113	38	56
3	117	151	38	56
4	157	189	38	56

Cutout: A + 20 mm x L + 20 mm

## Materials and finish

Slot: Aluminium  
 Standard finish: Natural anodised  
 Air guide baffle: Black ABS plastic

The diffuser is available in other colours. Please contact Lindab's sales department for further information.



# Plenum box

# STB/STU



## Description

STB is a rectangular plenum box for supply air for linear diffuser, MTL. The plenum box ensures even distribution over the linear diffuser. STB is equipped with a damper and an orifice plate to ensure individual regulation, and is supplied with acoustic insulation.

STU is a rectangular plenum box for air exhaust for linear diffuser, MTL. STU has the same properties as STB.

- Ensures even air distribution over the linear diffuser.
- Acoustically insulated.
- Supplied with damper and measuring device

## Maintenance

Cleaning of STB/STU is made more difficult because of the narrow space between slots. We therefore recommend that you ensure there are alternative cleaning options for the duct. To gain access to the box, the linear diffuser must be removed, as well as the plenum plate in the case of STB.

## Order code

<b>Product</b>	<b>STB/STU</b>	<b>a</b>	<b>a</b>	<b>ccc</b>
Type				
Slot size	15			
	19			
No. of slots				
Length (L)				

## Dimensions

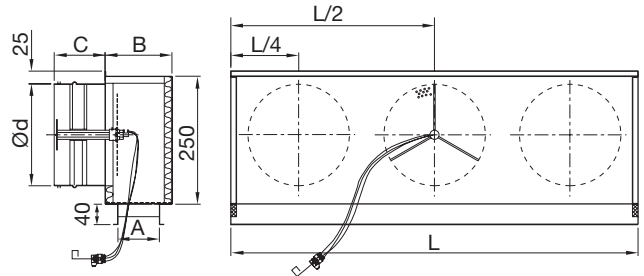

C dimension: STB = 100 mm  
STU = 200 mm

Box type / Length	1200-1799						1800-2000			
	Slot size				Number of connections					
No. of slots	15		19		Ød		Ød		Ød	
	A	B	A	B						
1	26	90	41	91	125	1	160	1	125	2
2	51	100	80	130	160	1	200	1	160	2
3	76	125	118	168	200	1	200	2	200	2
4	101	150	158	208	200	1	200	2	200	2

## Materials and finish

Plenum box: Galvanised steel  
Standard finish: Galvanised steel  
Insulation: Melamine foam plastic



# Pressure box

# VBA



## Description

VBA is a plenum box for supply and exhaust air intended to achieve a stable flow to a rectangular grille or other types of face plates. VBA is equipped with an adjustment damper and pressure measurement device. The plenum box can be connected from the side, the top or the back. The adjustment damper is operated from the front of the box by means of a graduated handle with integral lock function. VBA is equipped with a telescopic connection for easy installation. The same face plate and telescope are used as for WB boxes.

- Can be used for both supply and exhaust air
- Easy-to-detach face plate for access to duct
- Same box used for all front types

## Materials and finish

Box, plenum plate and damper are made of hot-galvanised steel plate.

## Order code

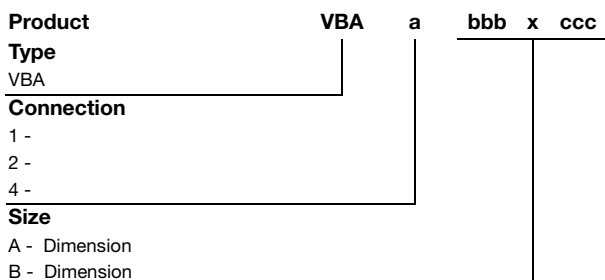

Example: VBA-2-500-200

## Dimensions

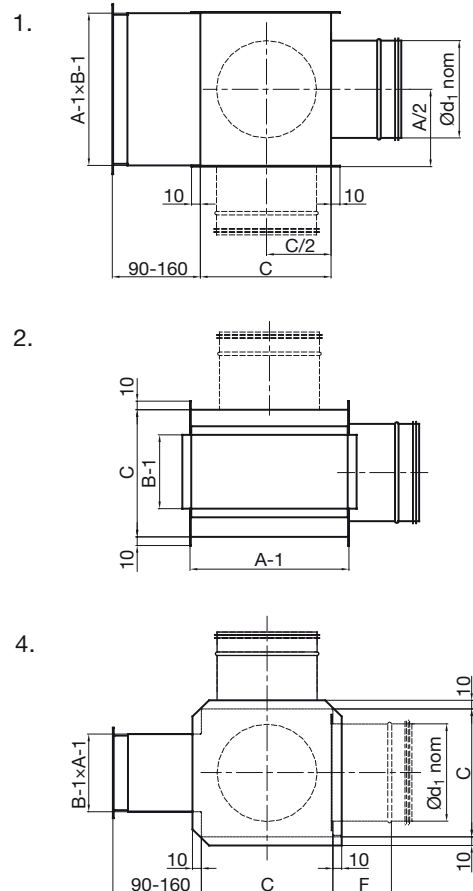

A x B	Ød <sub>1</sub> nom	C mm	F mm
200 x 100	125	165	90
300 x 100	160	200	110
400 x 100	160	200	110
500 x 100	200	240	130
600 x 100	250	290	155
800 x 100	250	290	155
1000 x 100	250	290	155
300 x 150	200	240	130
400 x 150	250	290	155
500 x 150	250	290	155
600 x 150	250	290	155
800 x 150	315	355	190
1000 x 150	315	355	190
300 x 200	250	290	155
400 x 200	250	290	155
500 x 200	315	355	190
600 x 200	315	355	190
800 x 200	315	355	190
1000 x 200	315	355	190
600 x 300	400	440	215



# Plenum box

# WB

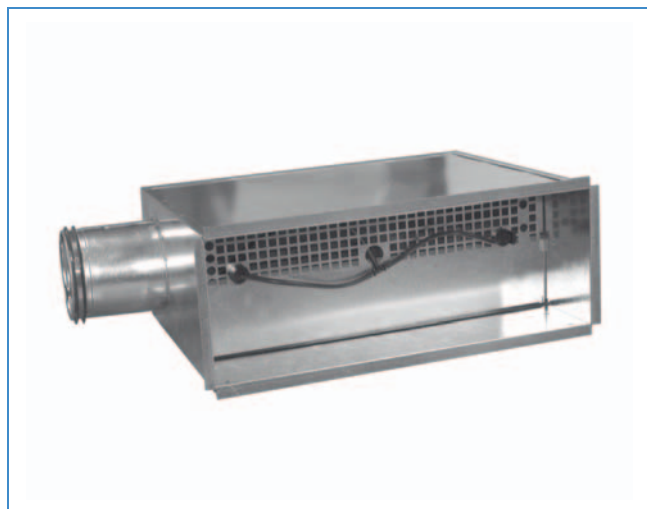

## Description

WB is a plenum box for supply air intended to achieve a stable flow to rectangular front plates or grilles. WB is equipped with an adjustment damper and pressure measuring device. The plenum box can be connected from the side or the back. The adjustment damper is operated from the front of the box by means of a graduated handle with integrated locking mechanism. WB is equipped with a telescopic connection that can be adjusted up to 50 mm, which provides flexibility during the installation phase. WB has a maximum width of 500 mm, which ensures that you can install the box in a standard wall structure with a centre distance of 600 mm between the plasterboard struts.

- Telescopic function
- Easy-to-detach face plate for access to duct
- Same box used for all front types

## Materials and finish

Plenum box: Hot-galvanised steel  
 Insulation: Melamine foam plastic

## Order code

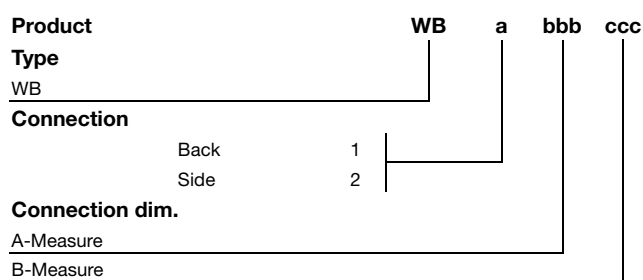

## Dimensions

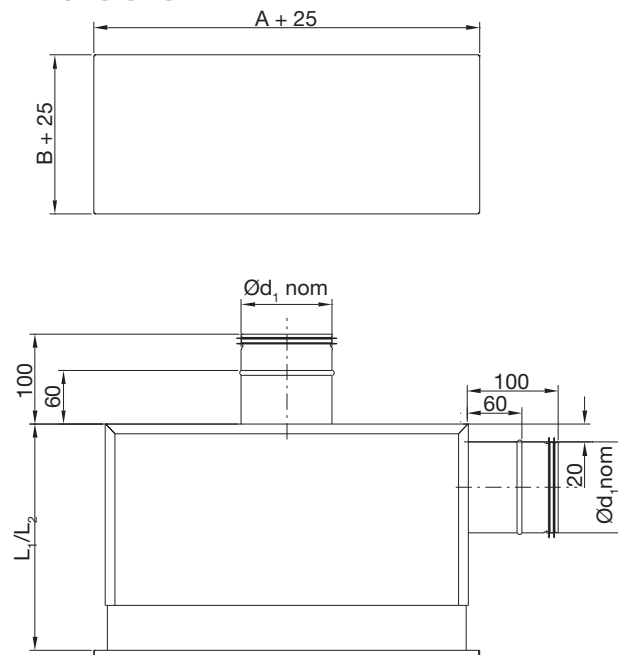

A x B	Ød <sub>1</sub> mm	A	B	L <sub>1</sub>	Side L <sub>2</sub>	Weight Kg
300 x 100	80	300	100	240-290	280-330	2,5
400 x 150	100	400	150	240-290	300-350	3,5
500 x 150	125	500	150	240-290	325-375	4,3
500 x 200	160	500	200	240-290	360-410	5,5
500 x 300	200	500	300	240-290	400-450	7,4



# Supply air nozzle

GD



## Description

GD is a rubber supply air nozzle suitable for ventilation of large areas where long throws are required. The nozzle can be adjusted for directional airflow, and can be installed directly into circular ducts, ( min. Ø250 mm ), or duct walls, ( min. height = 100 mm ). The nozzle can be used for both heated and cooled air.

- Directional airflow
- Long throws
- Simple installation

## Maintenance

The visible parts of the nozzle can be wiped with a damp cloth.

## Materials and finish

Nozzle: EPDM rubber, hardness 60, black

## Order code

Product **GD**  
 Type \_\_\_\_\_

## Dimensions

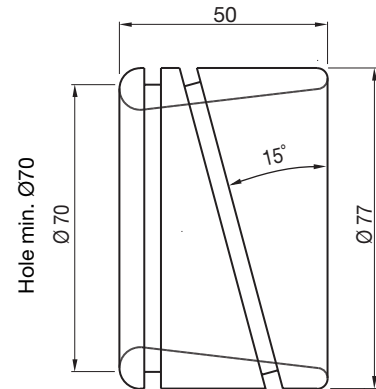

Free area: 0.0027 m<sup>2</sup>  
 Straight groove: for rectangular duct.  
 Oblique groove: for circular duct.

## Mounted in duct

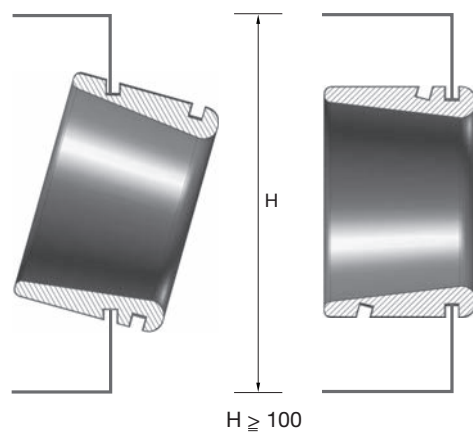
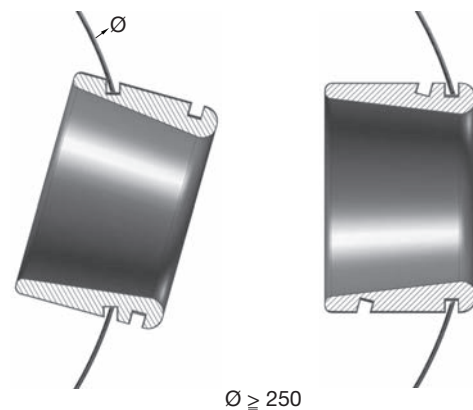

# Defroster nozzle

# DNOC



## Dimensions

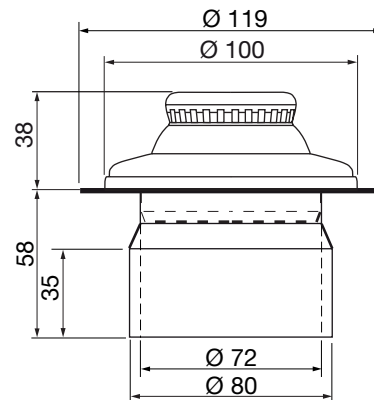

## Description

Jet nozzle for defrosting windows. Especially suitable for bridge or wheelhouse. Low installation depth.

- Swiveling range 40 degrees.
- Flow is infinitely adjustable.
- Installations depth 40 mm max.
- Projection opening 42 mm.

## Maintenance

The visible part of the nozzle can be wiped with a damp cloth.

## Options

The diffuser can be ordered separately without the socket for mounting directly in plenum box (DNO).

Socket can be ordered separately (VRSL)

## Material and Finish

Nozzle: ABS  
 Colour: Medium grey, S.U. 50  
 Socket: Galvanized steel, powder coated  
 Colour: RAL 7040

## Order code

Product DNOC



# Circular duct grille

# RGS

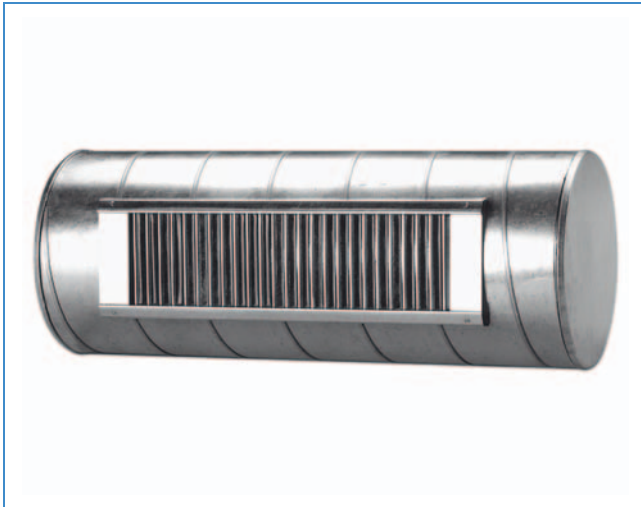

## Description

RGS is a rectangular ventilation grille with vertical adjustable bars for direct installation in circular ducts. The grille can be used for both supply and exhaust air. The grille can be supplied with horizontal directional bars, straight or slanting sliding damper or blade damper. The grille is designed so that the grille flanges always fit tight to the duct regardless of the duct diameter. RGS is made of hot-galvanised steel plate and is put together without welding. This means that the grille can be used without further surface treatment. The exterior of the grille thus matches the duct surface.

- Can be used for both supply and exhaust air
- Installed directly in circular duct
- Can be fitted with many types of accessory

## Maintenance

The grille should be removed to gain access to the duct.

## Order code

<b>Product</b>	<b>RGS</b>	<b>a</b>	<b>bbb</b>	<b>ccc</b>
Type				
Accessories				
A - measure				
B - measure				

A x B = Cutting dimension

## Dimensions

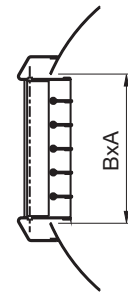
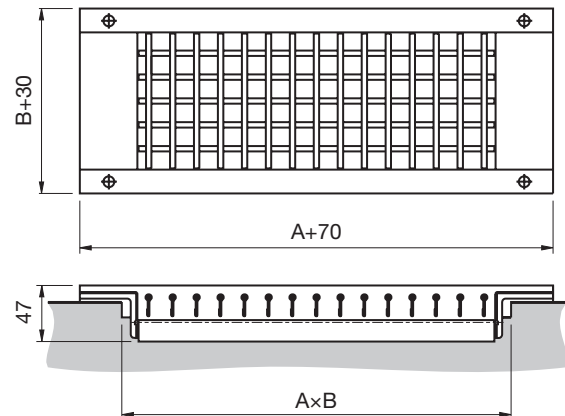

A x B = Cutting dimension

Screws included.

## Materials and finish

Grille:	Hot-galvanised steel
Sliding damper:	Electro-galvanised steel
Blade damper:	Electro-galvanised steel

The diffuser is available in other colours. Please contact Lindab's sales department for further information.



# Ventilator grill, standard

# B3020/B



## Description

B3020 is a rectangular aluminium grille with fixed horizontal bars. B3020 is used for both supply and exhaust air, and is supplied as standard with springs for installation in plenum boxes type VBA, WB or mounting frame type GGR. B3020 can also be used with volume regulator GAT.

## Maintenance

The grille should be removed to gain access to the plenum box or duct. The external parts should be wiped with a damp cloth.

## Accessories

Plenum box: VBA, WB  
 Mounting frame: GGR  
 Volume regulator: GAT

## Dimensions

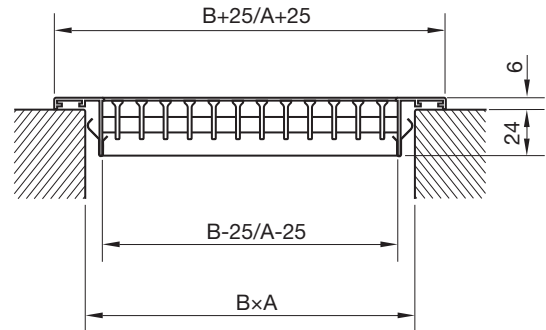

A mm	x	B mm	F m <sup>2</sup>	m kg
200	x	100	0,0072	0,30
300	x	100	0,0113	0,40
400	x	100	0,0155	0,50
500	x	100	0,0195	0,70
300	x	150	0,0189	0,60
400	x	150	0,0258	0,70
500	x	150	0,0326	1,00
600	x	150	0,0395	1,20
400	x	200	0,0265	0,80
500	x	200	0,0457	1,40
600	x	200	0,0553	1,60

Other sizes and types: see page 170.

## Order code

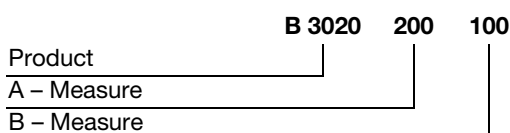

## Materials and finish

Grille: Aluminium  
 Standard finish: Natural anodised  
 On request: RAL 9010, gloss 30

The grille is available in other colours. Please contact Lindab's sales department for further information.





# Grille

# C20



## Dimensions

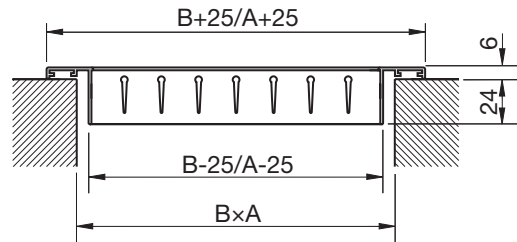

## Description

C20 is a rectangular aluminium grille with adjustable horizontal bars. C21 is also equipped with vertical directional bars for regulation of dispersal patterns. C20/C21 are used for supply air and are supplied as standard with springs for installation in plenum boxes type VBA, WB or mounting frame type GGR. C20/C21 can also be used with volume regulator GAT.

## Maintenance

The grille should be removed to gain access to the plenum box or duct. The external parts should be wiped with a damp cloth.

## Accessories

Plenum box: VBA, WB  
 Mounting frame: GGR  
 Volume regulator: GAT

A mm	x	B mm	F m <sup>2</sup>	m kg
200	x	100	0,0105	0,30
300	x	100	0,0164	0,40
400	x	100	0,0225	0,50
500	x	100	0,0283	0,70
300	x	150	0,0275	0,60
400	x	150	0,0375	0,70
500	x	150	0,0475	1,00
600	x	150	0,0574	1,20
400	x	200	0,0525	0,90
500	x	200	0,0664	1,40
600	x	200	0,0804	1,60

Other sizes and types can be supplied - see special grille C.

## Order code

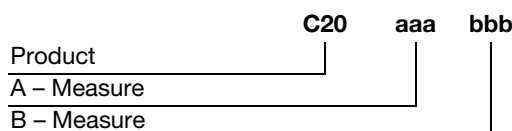

## Materials and finish

Grille: Aluminium  
 Standard finish: Natural anodized  
 On request: RAL 9003, gloss 30

The grille is available in other colours. Please contact Lindab's sales department for further information.



# Grille

# G20

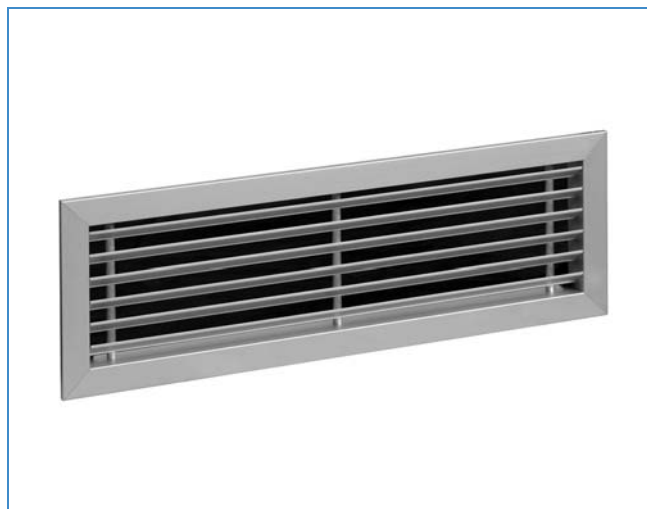

## Description

G20 is a rectangular aluminium grille with fixed slanting horizontal bars. G20 can be used for exhaust. G20 is supplied as standard with springs for installation in plenum boxes, type VBA. In the product photo the grille is shown with a VBA box.

## Maintenance

The grille should be removed to gain access to the plenum box or duct. The external parts should be wiped with a damp cloth.

## Accessories

Plenum box: VBA, WB  
 Mounting frame: GGR  
 Volume regulator: GAT

## Dimensions

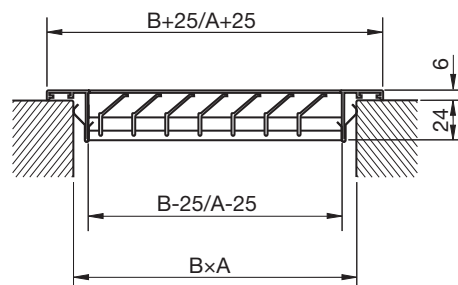

A mm	x	B mm	F m <sup>2</sup>	m kg
200	x	100	0,0066	0,30
300	x	100	0,0103	0,30
400	x	100	0,0141	0,40
500	x	100	0,0178	0,60
300	x	150	0,0172	0,50
400	x	150	0,0234	0,60
500	x	150	0,0297	0,90
600	x	150	0,0359	1,00
400	x	200	0,0328	0,80
500	x	200	0,0416	1,20
600	x	200	0,0503	1,40

## Order code



## Materials and finish

Grille: Aluminium  
 Standard finish: Natural anodised  
 On request: RAL 9003, gloss 30

The grille is available in other colours. Please contact Lindab's sales department for further information



# Grille

# F20

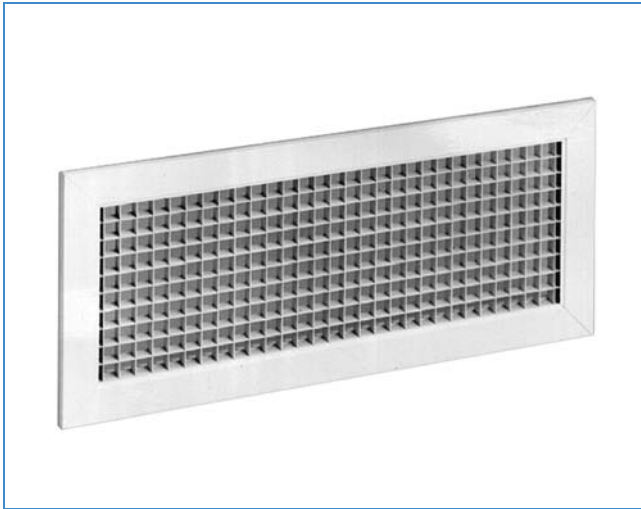

## Dimensions

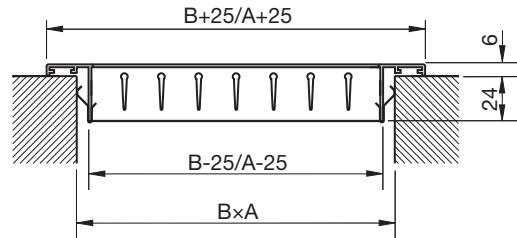

## Description

F20 is a rectangular aluminium grille with square grids. F20 is particularly suitable for air exhaust. F20 is supplied as standard with springs for installation in plenum boxes type VBA, WB or mounting frame type GGR. F20 can also be used with volume regulator GAT.

## Maintenance

The grille should be removed to gain access to the plenum box or duct. The external parts should be wiped with a damp cloth.

## Accessories

Pressure distribution box: VBA, WB  
 Mounting frame: GGR  
 Volume regulator: GAT

A mm	x	B mm	F m <sup>2</sup>	m kg
200	x	100	0,0111	0,20
300	x	100	0,0144	0,30
400	x	100	0,0240	0,30
500	x	100	0,0301	0,40
300	x	150	0,0292	0,30
400	x	150	0,0398	0,40
500	x	150	0,0504	0,50
600	x	150	0,0610	0,60
400	x	200	0,0557	0,50
500	x	200	0,0706	0,60
600	x	200	0,0854	0,70

For other sizes and types, see special grille F.

## Order code

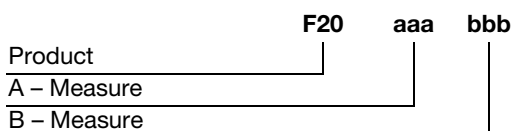

## Materials and finish

Grille: Aluminium  
 Standard finish: Natural anodised  
 On request: RAL 9003, gloss 30

The grille is available in other colours. Please contact Lindab's sales department for further information.



# Exhaust valve

KU



## Dimensions

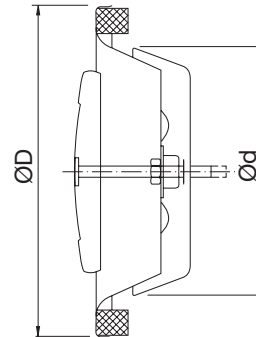

### Description

Valve for exhaust air.  
Designed for wall or ceiling mounting.  
Bayonet holders connect to socket VRGU, VRGL or VRGM.

### Materials and finish

**Material**  
Powder-coated galvanized sheet metal.

**Colour**  
White RAL 9003, gloss 30.

Ød nom	ØD mm	m kg
80	110	0,13
100	130	0,19
125	160	0,27
150	188	0,36
160	190	0,38
200	245	0,58

### Order code



# Exhaust valve

KSU



## Dimensions

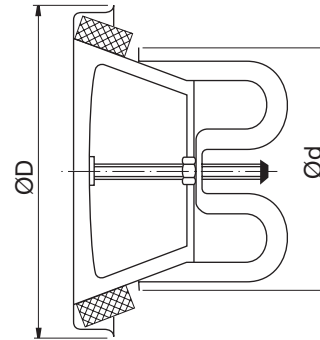

### Description

Valve for exhaust air.  
Designed for wall or ceiling mounting.  
Bayonet holders connect to socket VRGU, VRGL, or VRGM.

### Materials and finish

**Material**  
Painted galvanized sheet metal.

**Colour**  
White RAL 9003, gloss 30.

Ød nom	ØD mm	m kg
100	130	0,30
125	160	0,39
150	188	0,52
160	190	0,52
200	235	0,78

### Order code



# Exhaust valve

# URH



## Dimensions

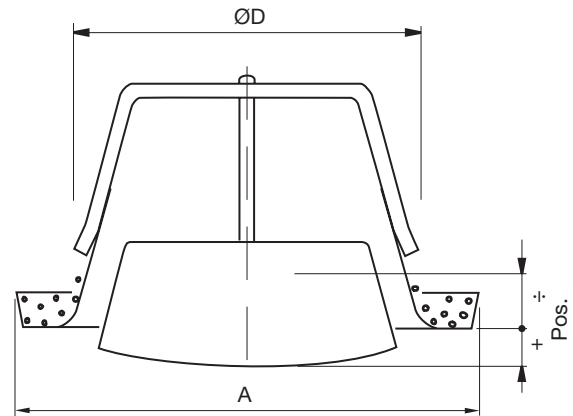

## Description

The URH valve is used for air exhaust. In special cases the URH valve can be used as an supply air valve for installation in a wall (relatively long throw).

The valve has a low sound power level even at a relatively large pressure loss. URH is supplied in four standard sizes: 100, 125, 160 and 200 mm.

The URH valve fits directly into Lindab pipes by means of a standard VRGL type bayonet fitting or VRGU or VRGM type valve bushing.

## Materials

Materials: Steel

## Maintenance

The visible parts can be wiped with a damp cloth.

ØD mm	A mm	Weight kg
100	140	0,30
125	165	0,40
160	200	0,60
200	250	0,90

## Order code

Product	URH	160
Type		
Size		



# Valve supply air



## Description

Valve for supply air.  
Designed for ceiling mounting.  
Bayonet holders connect to socket VRGU, VRGL or VRGM.

## Materials and finish

### Material

Powder-coated galvanized sheet metal.

### Colour

White RAL 9003, gloss 30.

## Dimensions

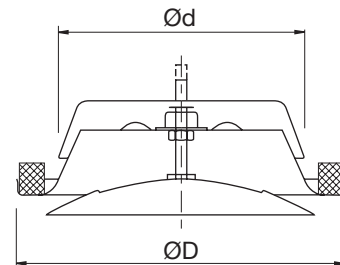

Ød nom	ØD mm	m kg
80	111	0,14
100	130	0,21
125	160	0,30
150	190	0,39
160	190	0,41
200	245	0,65

## Order code

Product	KI	125
Dimension Ød		



# Valve supply air

KIR



## Dimensions

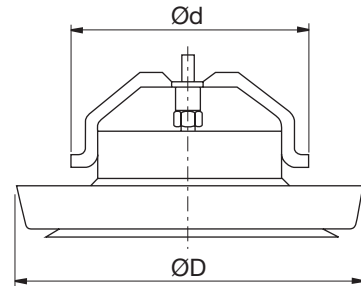

### Description

Valve for supply air.  
 Designed for ceiling mounting.  
 Equipped with a removable blanking-off sector plate for preventing the air flow in a desired direction.  
 Bayonet holders connect to socket VRGU, VRGL or VRGM.

### Materials and finish

**Material**  
 Coated galvanized sheet metal.

**Colour**  
 White RAL 9003, gloss 30.

Ød nom	ØD mm	m kg
100	135	0,28
125	165	0,44
160	205	0,62

### Order code

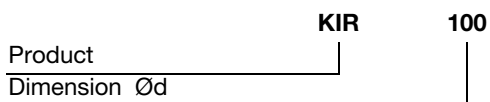



# Suspension ring

# UV25



## Dimensions

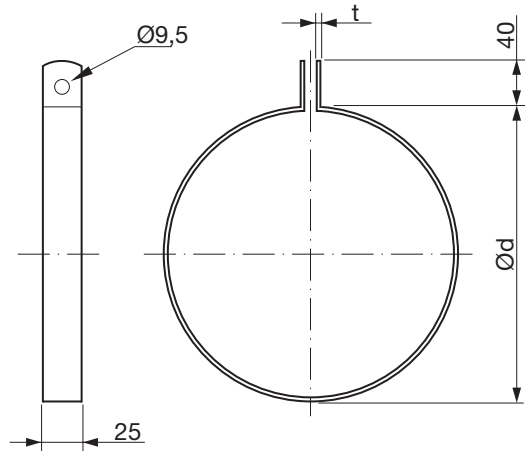

## Description

For suspension of circular ducting. At insulated duct it is recommended that the suspension ring is mounted inside the insulation.

Also available in other dimensions up to Ø400.

Ød nom	t mm	m kg
80	2,0	0,13
100	2,0	0,15
125	2,0	0,18
160	2,0	0,22
200	2,0	0,27
250	2,0	0,33

## Order code

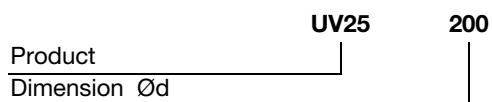

# Suspension ring

# UVH25



## Dimensions

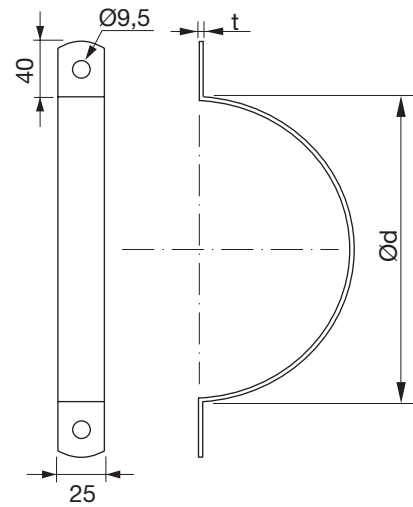

Ød nom	t mm	m kg
80	2,0	0,20
100	2,0	0,20
125	2,0	0,20
160	2,0	0,20
200	2,0	0,30
250	2,0	0,30

## Description

For suspension of circular ducting. At insulated duct it is recommended that the suspension ring is mounted inside the insulation.

N.B. Is sold in pairs.

Also available in other dimensions up to Ø400.

## Order code

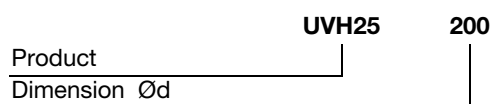

# Suspension rings

# UVHM25



## Description

UVHM25- mounting brackets for ducts.

### Material:

Two half parts galvanized sheets 25 x 2.0 mm. one part mounted with an M8 popnut.

### NB.

Is sold in pairs.  
The weight is per pair.

Also available in other dimensions up to Ø400.

## Dimensions

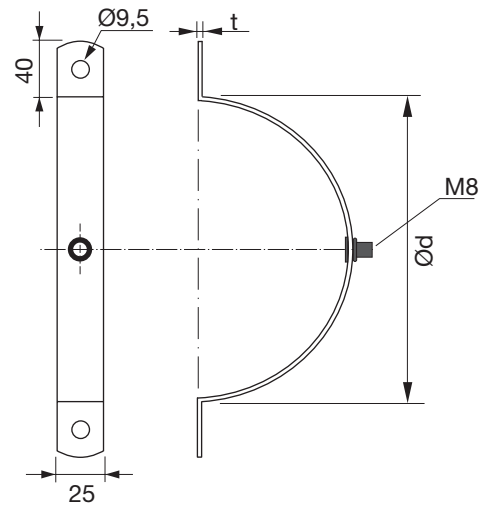

Ød nom	t mm	m kg
80	2,0	0,20
100	2,0	0,20
125	2,0	0,20
160	2,0	0,20
200	2,0	0,30
250	2,0	0,30

## Order code

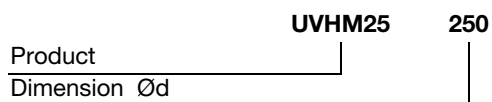

# Suspension rings

# UVHGM25



## Dimensions

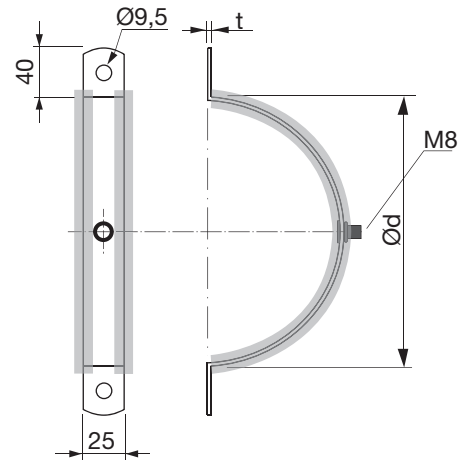

## Description

Suspension clamp with antivibration rubber.

### Material:

Two half parts galvanized sheets 25 x 2.0 mm with antivibration rubber, one with an 8 mm threaded bushing.  
At insulated duct it is recommended that the suspension clamp is mounted inside the insulation.

### NB.

Is sold in pairs.  
The weight is per pair.

For intermediary dimensions, please contact Lindab.

Also available in other dimensions up to Ø400.

Ød nom	t mm	m kg
80	2,0	0,20
100	2,0	0,20
125	2,0	0,20
160	2,0	0,20
200	2,0	0,30
250	2,0	0,30

## Order code

Product	UVHGM25	250
Dimension Ød		



# Suspension clamp

# INUV25



## Dimensions

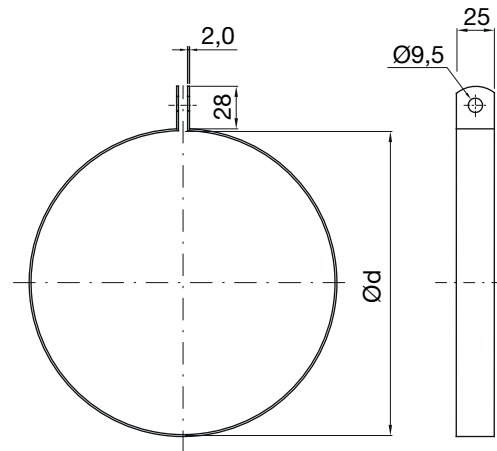

## Description

Clamp with short ear, for suspension of circular ducting in restricted spaces.  
 For insulated duct it is recommended that the suspension ring is mounted inside the insulation.

Ød nom	m* kg
80	135
100	159
112	173
125	180
132	199
157	230
160	235
180	258
192	274
200	284
224	313
232	323
250	346
260	359
280	383
300	407
315	427
355	477

## Order code

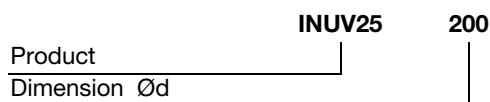

# Suspension clamp

# INUVG25



## Dimensions

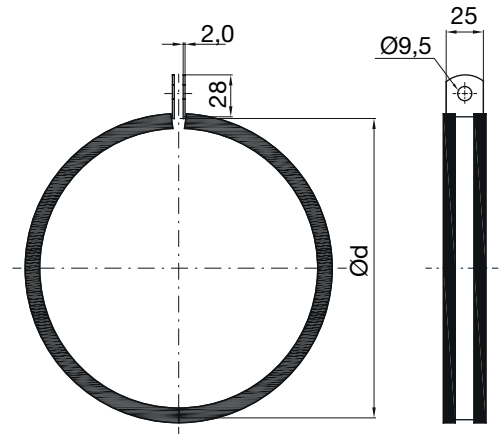

## Description

Clamp with short ear, with vibration-damping internal rubber lining, for suspension of circular ducting in restricted spaces.

For insulated duct it is recommended that the suspension ring is mounted inside the insulation.

Ød nom	m* kg
80	179
100	211
112	230
125	242
132	264
157	306
160	312
180	343
192	364
200	377
224	416
232	429
250	459
260	478
280	509
300	541
315	567
355	634

## Order code

Product	INUVG25	200
Dimension Ød		



# Flexible duct clamp

# MDC



## Dimensions

Ød nom
60 - 110
60 - 135
60 - 165
60 - 215
60 - 270
60 - 325
60 - 425
60 - 525
60 - 660

## Description

A metal clamp for all types of flexible ducting. The clamp consists of the band FDB and the flip-up band lock FDBL. This system allows an easy and quick application thanks to the automatic locking that forms the right diameter of the duct.

## Advantages

- Labour saving.
- The band has lifted edges to avoid damage to the ducting.

## Technical data

Band width .....	9 mm
Band and lock material .....	Stainless steel AISI 430
Screw material .....	Galvanized steel
Screw head .....	Hex Head 7 mm A/F

## Order code

	<b>MDC</b>	<b>135</b>	<b>SS</b>
Product			
Dimension Ød			
Material			



# PP Metalized Tape

# MT TAPE



## Dimensions

Code	Width mm	Length m
TAPE	50	50
TAPE	75	50

## Description

Single sided self adhesive tape with aluminium dust. Used to steam tighten AC or central heating systems. Due to its good adhesive properties and low side penetration by water and solvents, it is also widely used in other branches.

### Material

Polypropylene (PP), metalized.

### Colour

Shiny silver.

### Temperature range

-20-80 °C.

### Total thickness

0,05 mm.

## Order code

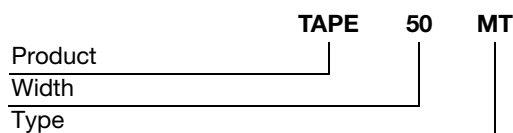



# Reinforced Aluminium Insulation Tape

# RAI TAPE



## Dimensions

Code	Width mm	Length m
TAPE	50	50
TAPE	75	50
TAPE	100	50

## Description

Single sided self-adhesive aluminium tape reinforced with 5x5 mm carbon fibre net, laminated with polyethylene. Higher mechanical durability as compared to plain tape. Widely used in technical assemblies.

### Material

Aluminium, reinforced.

### Colour

Shiny silver.

### Temperature range

-25-70 °C.

### Total thickness

0,15 mm.

## Order code

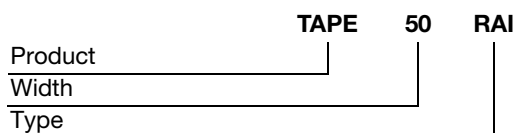

# Flexible duct, insulated

# ISODEC



## Dimensions

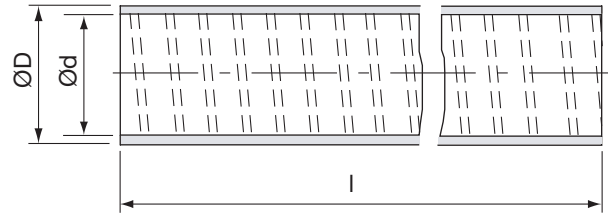

## Description

ISODEC is a flexible duct made of non-combustible wool ( $t = 25 \text{ mm}$ ,  $d = 16 \text{ kg/m}^3$ ), internally faced with a duct made of aluminum, reinforced with a spiral steel wire and externally faced with a vapor barrier made of reinforced aluminum foil.

Withstands temperatures from  $-30^\circ\text{C}$  to  $+250^\circ\text{C}$ .

$\text{Ød}$ nom	$\text{ØD}$ mm	$l$ mm	$m$ kg/m
80	130	10000	0,55
100	150	10000	0,75
125	175	10000	0,90
160	210	10000	1,20
180	230	10000	1,50
200	250	10000	1,80
250	300	10000	2,16

## Order code

Product	ISODEC	125
Type		



# Semiflexible double duct

# SRFC

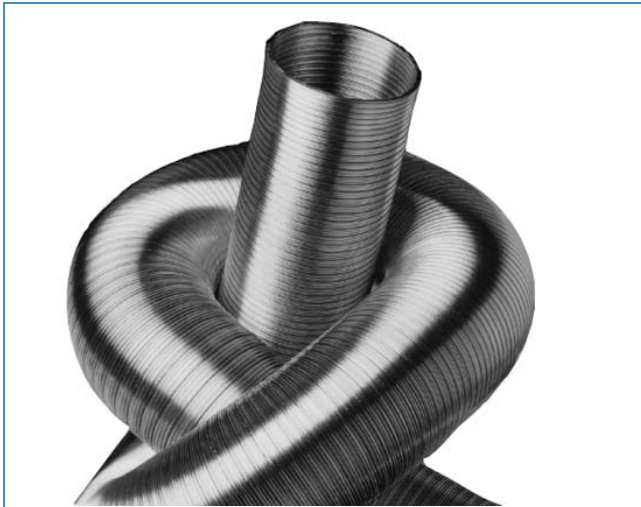

## Dimensions

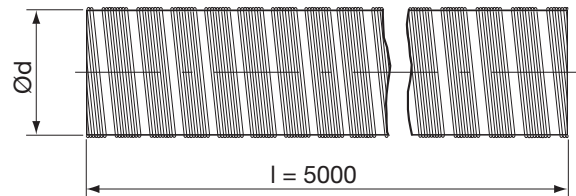

### Description

Double-layer duct wall.

### Applications

Suitable for mechanical air supply systems and air conditioning systems

### Advantages

- Small storage and transport volume.

### Technical data

Duct material.....	Aluminium + aluminium (AL)
Minimum bending radius.....	1×d
Maximum temperature.....	+200 °C
Fire resistance.....	Not flammable in accordance with DIN 4102 class A1
Delivery length:	
Ø 63–315.....	Compressed to 1,2 m
Standard length.....	5 m

Ød nom	O πd m	A πd <sup>2</sup> /4 m <sup>2</sup>	Max. pres- sure Pa	m kg
63	0,198	0,003	±3150	1,30
80	0,251	0,005	±3150	1,70
100	0,314	0,008	±3150	2,10
125	0,393	0,012	±3150	2,60
140	0,440	0,015	±3150	2,90
150	0,471	0,018	±2500	3,10
160	0,503	0,020	±2500	3,30
180	0,565	0,025	±2500	3,70
200	0,628	0,031	±2500	4,20
224	0,704	0,039	±2500	4,60
250	0,785	0,049	±2000	5,20

### Order code

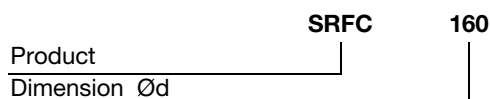

# Dimensions

The dimension range, measures, colours and ways of how to build the products shown in this catalogue are general and the most frequent ones. Please be aware of that local variations may occur.

## Designations and examples

These designations and dimensions of ducts and fittings are adapted to CEN standards.

Lengths are given in mm.

Angles are given in degrees.

Fittings with  $\varnothing d_1 - \varnothing d_4$  fit inside ducts and fittings with  $\varnothing d$ .

Duct and female dimension .....	$\varnothing d$
Connector dimension .....	$\varnothing d_1, \varnothing d_2, \varnothing d_3, \varnothing d_4$
Sheet metal thickness .....	t

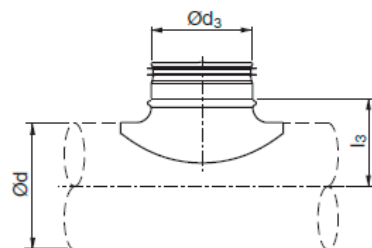
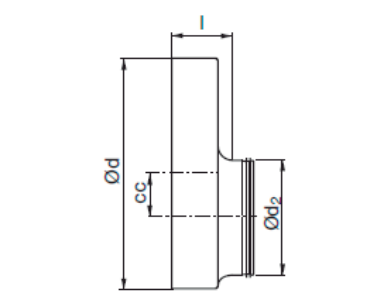
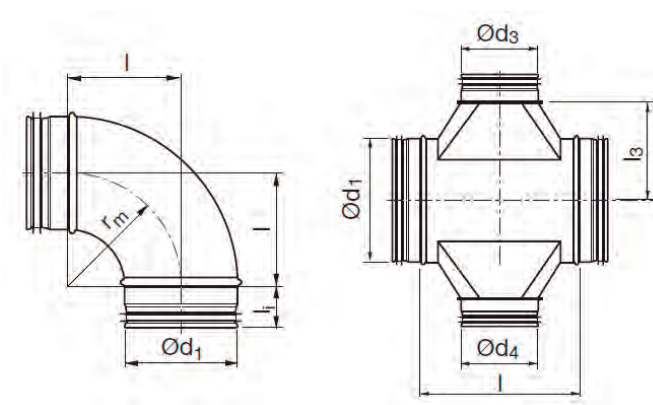
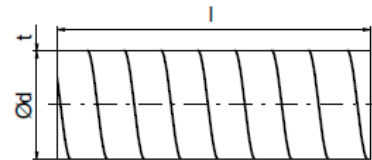

Installation length .....	$l, l_1, l_2, l_3$
Bend radius .....	$r_m$
Insertion length .....	$l_i$
Eccentricity .....	cc
Component length .....	L
Circumference .....	O
Cross-sectional area .....	$A_c$
Mass .....	m
Linear mass .....	$m_l$

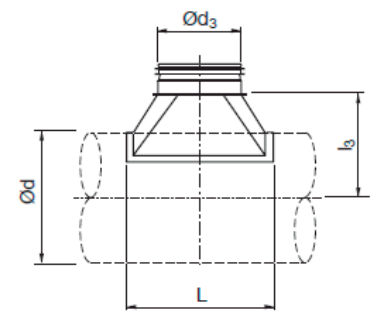

# Tolerances

Bold face denotes standard dimensions

Standard face denotes intermediate dimensions.

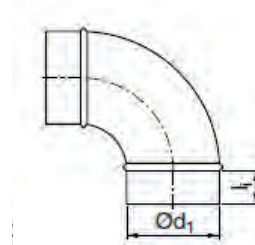
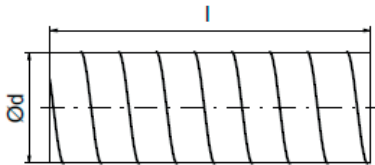

## Ducts

Ød nom	Tolerance range
63	63 - 63,5
80	80 - 80,5
100	100 - 100,5
112	112 - 112,5
125	125 - 125,5
140	140 - 140,6
150	150 - 150,6
160	160 - 160,6
180	180 - 180,7
200	200 - 200,7
224	224 - 224,8
250	250 - 250,8

## Fittings

Ød nom	Tolerance range	li nom
63	61,8 - 62,3	40
80	78,8 - 79,3	40
100	98,8 - 99,9	40
112	110,8 - 111,3	40
125	123,8 - 124,3	40
140	138,7 - 139,3	40
150	148,7 - 149,3	40
160	158,7 - 159,3	40
180	178,6 - 179,3	40
200	198,6 - 199,3	40
224	222,5 - 223,3	40
250	248,5 - 249,3	60

## Length

l, l1, l3 etc.	Tolerance	
0 - 15	+ 0	- 2
16 - 100	+ 0	- 5
101 -	+ 0	- 10
L	± 5	

## Angle

α	Tolerance
	± 2

## Weight

± 10 %

## Sheet metal thickness

As in sheet metal standard EN 10143:1993

# Materials

## Sheet metal quality

Fittings and ducts from Lindab's standard programme are manufactured from zinc coated sheet metal. This means that the base material shall be hot dipped zinc galvanized steel sheet metal with a yield point of approx. 200 N/mm<sup>2</sup>, and that the galvanization shall be minimum as class Z 275. This surface treatment corresponds to the corrosivity category C3.

## Sheet metal thicknesses

Other thicknesses of sheet metal can be supplied. You will have to expect some changes to the product range, however. For example, an increase in thickness in the ducts of 0,5 mm means that the internal diameter falls by 1,0 mm, which means in turn that standard fittings do not fit, and will have to be specially made for these ducts.

## Sheet metal thicknesses

Corrosivity category	Environmental corrosivity	Sheet metal material
C3	Moderate	Galvanized (Z275)
C4	High	Aluminium, plastic coated, aluminium-Zinc (AZ185) and stainless steel (acid proof)
C5 - I	Very high (industrial)	Stainless steel (acid proof)
C5 - M	Very high (Marine)	Stainless steel (acid proof)

# The Safe system

Safe is a quickly assembled system for round ventilation ducts. Safe is type approved to class D by SITAC, no. 1358/88. The complete programme has dimensions according to Eurovent 2/3 and Swedish Standard SS-EN 1506.

The system is based on a double-lipped, factory installed seal made from EPDM rubber. The moulding, which can withstand rough handling, and is almost insensitive to temperature changes, gives a very airtight seal.

## Click function

The Click function exists in principle on all Safe-products. The Click function exists on the dimensions Ø 80–315. The Click function means; **a.** that an end with male measure has an open turned-over end **b.** that an end with female measure has a number of notches.

## Type approval

Approval no. 1358/88 means that the Safe-system complies with the requirements for tightness class D without any demand for pressure testing after installation. The approval is only valid on condition that all fittings are marked by us in accordance with the example and are installed in accordance with the accompanying installation instruction.

## Tightness

A duct system will never be “completely tight”. The system will normally have some leaks at joints between ducts and fittings. The leakage will also increase as the pressure difference between the in- and outside of the duct sides increases. The leakage factor in (l/s)/m<sup>2</sup> is always specified in relation to the pressure difference in Pa. (The unit (l/s)/m<sup>2</sup> denotes the leakage flow in l/s in or out of the system in relation to its duct area in m<sup>2</sup>.)

Present-day stringent demands for interior climate entail expensive air treatment. Leakage leads to uneconomical operation, adjustment difficulties and over-dimensioned equipment. For this reason, it is important that ventilation systems are very well sealed, to keep overall costs down. This is why official requirements for sealing vary with the size and use of systems.









# We simplify construction

At Lindab we are driven by a strong desire to continuously generate improvements and to simplify construction. We do that by developing products and solutions that are easy to use and energy efficient, together with industry leading knowledge, support, logistics and efficient availability. We want to simplify everything – from designing, ordering, delivery, goal achievement and mounting to the entire way of doing business with us. By simplifying in every stage of the construction process, we also contribute to energy efficiency.

A good thinking company. Good thinking is a deeply rooted philosophy that guides us in everything we do. We firmly believe that good thinking makes good solutions to the challenges we all face. Taking responsibility for what we do and how we do things is therefore important to us. Because good thinking is not only about making life easier and more comfortable for our customers and end users. It is also a matter of thinking in a global perspective, all the time. Knowing that we at Lindab are helping to make the world a better place.

# Certificates and approvals

The Lindab ventilation solutions hold type and fire approvals of the leading classification authorities.



This is just a small selection of certificates and approvals. Please go to [lindabmarine.com](http://lindabmarine.com) for more information.





# References

Lindab has more than 35 years experience of supplying ventilation solutions to the marine and offshore industry with more than 2000 reference projects.

- 6 x AHTS, Kleven Norway
- Air Craft Carriers, BAE UK
- Disney Fantasy, Meyer Werft
- Costa Favolosa, Fincantieri
- Color Line Magic, STX Finland
- Heidrun
- Ekofisk
- Moho Bilondo
- Quantum/Oasis Class, Meyer Germany & Finland
- F-125 Fregates, Thyssen Krupp Germany
- Luxury yacht, Amels Netherlands
- Luxury yacht, Oceanco Netherlands

Get in  
touch with  
**Lindab**

> [www.lindab.co.uk](http://www.lindab.co.uk)

> [sales@lindab.co.uk](mailto:sales@lindab.co.uk)



Most of us spend the majority of our time indoors. Indoor climate is crucial to how we feel, how productive we are and if we stay healthy.

We at Lindab have therefore made it our most important objective to contribute to an indoor climate that improves people's lives. We do this by developing energy-efficient ventilation solutions and durable building products. We also aim to contribute to a better climate for our planet by working in a way that is sustainable for both people and the environment.

[Lindab](#) | For a better climate