

ENGLISH

This directions for use contains following products:
Roof fans CRF/RFS and VDF/HDF.

DESCRIPTION

CRF/RFS and VDF/HDF roof fans with backward curved impeller. They are manufactured from galvanized steel sheet which is polyester plastic coated.

The fans are equipped with external rotor induction AC or EC-motor with maintenance-free sealed ball-bearings

APPLICATION

- CRF/RFS and VDF/HDF are accessible for the user, according to IEC 60335-2-40, to by themselves do the service and maintenance, according to this Directions for use. But before this work the unit must be currentless.

With reservation according to IEC 60335-2-7.12 "This appliance is not intended for use by persons (including children) with reduced physical, sensory or mental capabilities, or lack of experience and knowledge, unless they have been given supervision or instruction concerning use of the appliance by a person responsible for their safety."

"Children should be supervised to ensure that they do not play with the appliance."

- The fan is used for transportation of "clean" air, meaning not intended for fire-dangerous substances, explosives, grinding dust, soot, etc.
- To achieve maximum life time for installations in damp or cold environments, the roof fan should be operating continuously.
- The fan is intended to be used at the max voltage and frequency that's stated on the label on the fan.
- The fan complies with environmental requirement M2.

HOW TO HANDLE

- The fan must be transported in its packing until installation. This prevents transport damages, scratches and the fan from getting dirty.
- Avoid extreme heat or cold (temperature range for storage and transport).

- Avoid prolonged storage; we recommend a maximum of one year (consult the manufacturer before starting if stored for longer).

ASSEMBLY INSTRUCTION

If there is not enough knowledge always turn to a professional when mounting

- The easiest way is to mount is with roof curb..

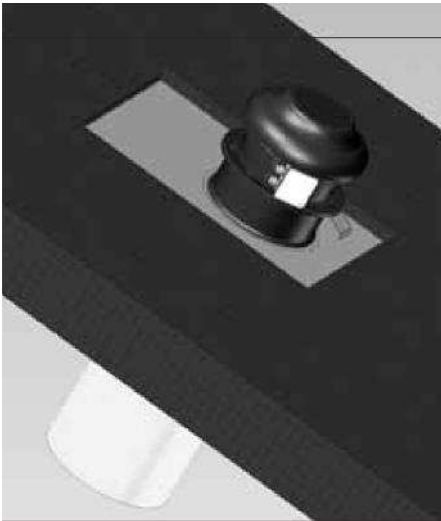

CRF mounted on the roof curb. Consider how the fan is open when cleaning. See to that the inlet frame is tight towards the roof curb so no water can infiltrate.

- The easiest way is to mount RFS and VDF/HDF is with roof curb..
NB? The exhaust air of VDF/HDF can be change, horizontal or vertical, see page 12.

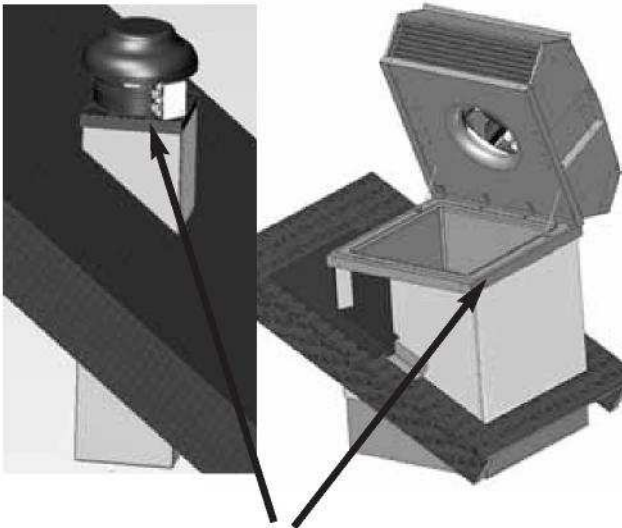

RFS and VDF/HDF mounted on the roof curb. Consider how the fan is open when cleaning. See to that the inlet frame is tight towards the roof curb so no water can infiltrate.

		OWE.
		'411111
TKC	TKS	VDF/HDF

The fan should be mounted in a way so cleaning and maintenance easily can be done. Beware of the air direction when mounting. Consider the weight of the fan.

- Make sure that the access cable is not damage at mounting and installation.
- The fan must be connected to duct. N131 Do not start the fan before it is duct connected.
- The fan must be mounted in a safe way. Make sure that no foreign objects are left behind in the fan/duct.
- Before the fans placement is decided, the roof beams must be located.
- Make sure that the joists have bearing capacity enough for the fan and roof curb. Under normal circumstances fan and roof curb can be mounted in average joists. If in doubt turn to a professional for calculation. For fan weight please see the product label.
- Consider the distance from the fan outlet to combustible building component is according to standards.
- Before starting the fan the installation must be inspected. Consider the placement, so there is enough space when open the fan for cleaning and maintenance. Make sure that the access cable is not damaged when open the fan.
- The fan should be installed in a way that vibrations can not be transfused to duct or framework.

CONVERSION FROM VERTICAL TO HORIZONTAL

To convert a VDF into a HDF.

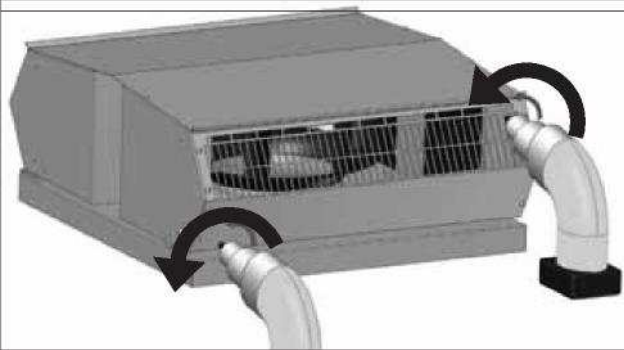

Loosen the safety grille.

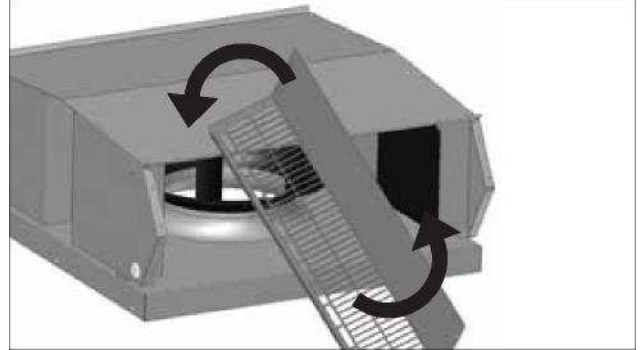

Turn the safety grille around.

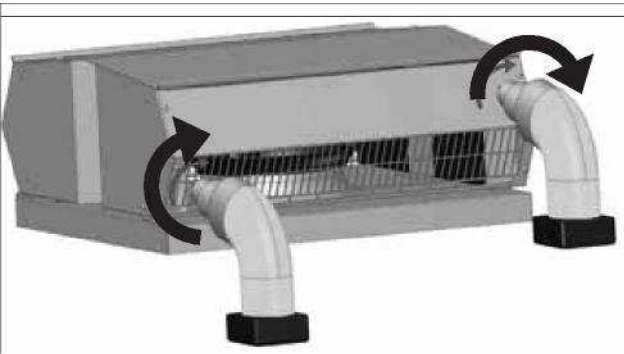

Mount the safety grille back. Do the same on both outlets. Now, the VDF is converted into a HDF. Make a HDF into a VDF in the similar way.

INSTALLATION

- The fan must be installed according to the air direction label on the fan.
- The fan must be connected to duct or equipped with a safety grille.
- The fan should be installed in a safe way and make sure that no foreign objects are left behind.
- The fan should be installed in a way that makes service and maintenance easy. N.B.? Consider the weight and size of the fan.
- The fan should be installed in a way that vibrations not can be transfused to duct or building. To provide this, use for example a flange.
- Electrical installations must be made by an authorized electrician.
- See Wiring diagram at the lid of the junction box.
- Electrical installation must be connected to a locally situated isolator switch or by a lockable main switch.
- Control that the fan is installed and connected electrically in the right way, grounded and with motor protection.
- For single phase fans a residual current device is used (type A).

AC-MOTOR

- For speed regulation of AC motor a transformer or thyristor can be connected.
- The AC motor has a built-in thermal contact.
- The capacitor (only for AC motor) has finite lifetime and should be exchanged after 45.000 operation hours (about 5 years of operation) to secure maximum function. Defective capacitor can cause damage.

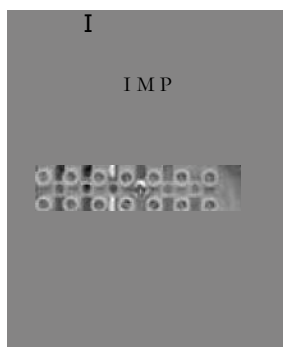

EC-MOTOR

- Speed regulating of EC motor can be done with the built-in potentiometer, 0-10 V.

An external potentiometer can be connected to the terminal if necessary. The internal potentiometer should then be



- The EC motor has tachometer output one pulse per revolution.
 - EMC-compatible installation of external control lines: The control cable must not be longer than 30 m. Screened control cables must be used when the cable length is longer than 20 m. When using a shielded cable connect the shielding to one side only, i.e. only to the device with the protective ground (keep cable short and with as little inductance as possible?). Pay attention to sufficient distance from power lines and motor wires to prevent interferences.
- Attention!** Ensure correct polarity? Never apply line voltage to analog inputs?
- The EC motor has electronically thermal-/over-voltage protection.

OPERATION

For technical data please see the product label. Before starting, make sure that:

- the current does not exceed more than +5% of what is stated on the label.
- the connecting voltage is in between +6% to — 10% of the rated voltage.
- no noise appears when starting the fan.

ENGLISH

MAINTENANCE

- Before service, maintenance or repair begins, the fan must be tension free and the impeller must have stopped.
- Attention, look out for sharp edges and corners.
- Consider the weight of the fan when removing or opening larger fans to avoid jamming and contusions.
- **Attention!** Temperatures up to 85°C can be present on the controller housing (only for EC motor).
- **Waiting period of at least 3 minutes!** (only for EC motor) Because of internal capacitors, danger of death exists even after switching off the device through directly touching the energized parts or due to parts that have become energized due to faults. The controller housing may only be removed or opened when the power line has been switched off and a period of three minutes has elapsed since switching it off.
- When cleaning and maintaining, the fan always have to be secured when open, so it can't fall down and cause injury.
- The fan must be cleaned when needed, at least once a year to maintain the capacity and to avoid unbalance which may cause unnecessary damages on the bearings.
- When cleaning the fan, high-pressure cleaning or strong dissolvent must not be used. Cleaning should be done without dislodging or damaging the impeller.
- The fan bearings are maintenance-free and should be renewed only when necessary.
- Notice the weight of the fan when closing after inspection/cleaning.
- Mount back all details in reverse order. Check that the fan is closed and locked before starting.
- Make sure that there is no noise from the fan.

WARRANTY

The warranty is only valid under condition that the fan is used according to this "Directions for use" and a regular maintenance has been made and record. The warrantor is responsible only for the operation if approved

accessories are used. The warranty does not cover product failures caused by accessories/equipment from other manufacturers.

FAULT DETECTION

1. Make sure that there is power to the fan.
2. Cut the power and verify that the impeller is not blocked.
3. Check the thermal contact (for AC). If it is disconnected the cause of overheating must be taken care of, not to be repeated. To restore the manual thermal contact, cut the power for a couple of minutes. Larger motors than 1,6 A may have manual resetting on the motor. If it has automatic thermal contact the resetting will be done automatically when the motor has cooled.
4. Make sure that the capacitor is connected according to the wiring diagram (for AC).
5. If the fan still does not work, the first thing to do is to change the capacitor (for AC).
6. If nothing of this works, contact your fan supplier.
7. If the fan is returned to the supplier, it must be cleaned, the motor cable undamaged and a detailed nonconformity report enclosed.