

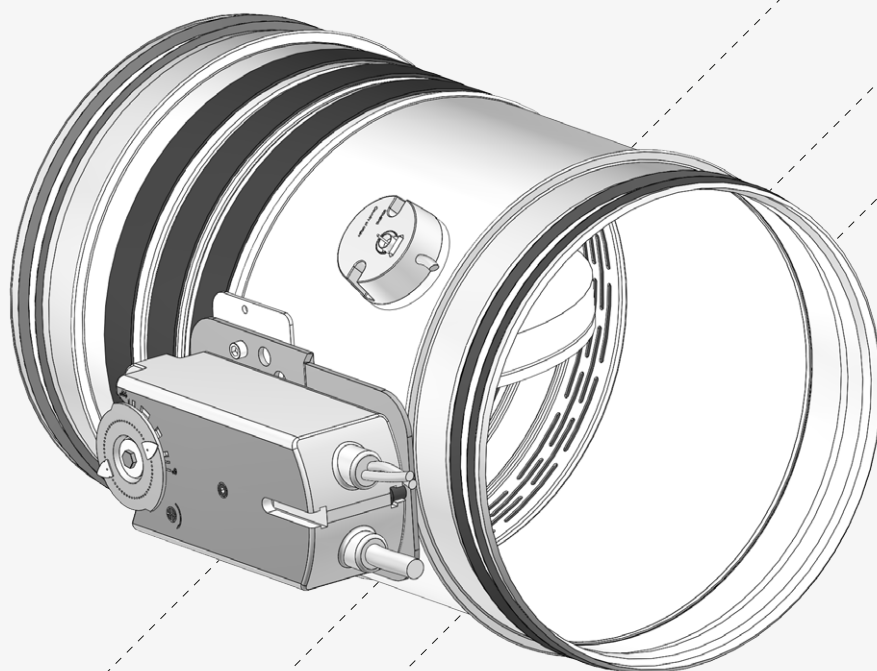

WH25  
LINDAB SAFE



Technical Manual  
English

PATENTED FIRE DAMPER  
CIRCULAR SERIES WH25 - 500 Pa

Cert. N° 1812-CPR-1023  
Installation type with fire resistance class



This is a 50 page manual.

<b>Overview</b>	<b>p. 4</b>
Description	p. 4
General characteristics	p. 4
European Standards applied	p. 4
Certifications and approvals	p. 4
Components	p. 4
Available dimensions	p. 5
Performances	p. 5
Fire resistance classification according to EN 13501-3-2009	p. 5
Mechanism type	p. 8
<b>Technical data</b>	<b>p. 11</b>
Dimension	p. 11
Weights	p. 11
<b>Installation</b>	<b>p. 12</b>
Intended use	p. 12
Not allowed uses	p. 12
Positioning brackets before fixing	p. 12
Blade rotation axis positioning	p. 12
Installation of flexible connectors in order to balance out the ventilation ducts expansion	p. 12
Transfer Application (application not connected to air ducts on one or both sides)	p. 13
Minimum distances	p. 15
Construction supports characteristics	p. 17
Installations within vertical rigid wall	p. 19
Installations within vertical light wall (plasterboard)	p. 21
Installations within vertical light wall (gypsum blocks wall)	p. 22
Installations within floor	p. 23
Installations within vertical wall with Fire Batt (Weichschott) sealing	p. 24
Installation within floor with Fire Batt (Weichschott) sealing	p. 25
Installation remote from the vertical rigid wall and the vertical light wall (gypsum blocks wall)	p. 26
Installation remote from the vertical light wall (plasterboard)	p. 28
Installations remote from the vertical wall with Fire Batt (Weichschott) sealing	p. 30
Installations remote from the floor	p. 32
Installation within vertical light wall (Shaft wall)	p. 34
<b>Electrical connections</b>	<b>p. 35</b>
Electrical wiring	p. 35
Electrical specifications	p. 36
<b>Maintenance and inspections</b>	<b>p. 38</b>
Periodic inspection and cleaning	p. 38
Repair	p. 38
Disposal	p. 38
<b>Selection</b>	<b>p. 39</b>
Air flow rates in relation to the diameter	p. 39
Air flow rates as a function of the pressure drop	p. 39
Air flow rates as a function of generated sound levels	p. 39
Pressure drop and sound level graph	p. 40
Sound spectrum table	p. 40
<b>Accessories and spare parts</b>	<b>p. 41</b>
<b>How to order</b>	<b>p. 45</b>
Motorized fire dampers	p. 45
Fire damper with manual control	p. 45
Electric motor driven actuators	p. 45
<b>Specification Text</b>	<b>p. 46</b>
Series WH25 compact circular fire dampers	p. 46
<b>Revision Index</b>	<b>p. 48</b>

## OVERVIEW

### Description

Fire dampers WH25 are devices for use in heating, ventilation and air-conditioning (HVAC) systems at fire boundaries to maintain compartmentation and protect means of escape in case of fire. They satisfy integrity, insulation and smoke leakage criteria for the declared time of fire resistance.

Tested and classed in accordance with EN 1366-2 and EN 13501-3 regulations with 500 Pa depression.

Studied and optimized for small diameter ducts and reduced installation space focusing on aerualic and acoustical performance.

Equipped with various different mechanisms completely outside the wall, easily interchangeable even after installation.

### European Standards applied

CE certification	EN 15650
Test	EN 1366-2
Classification	EN 13501-3
Thermal fuse reliability	ISO 10294-4
Air tightness	EN 1751
Resistance to corrosive environments	EN 60068-2-52

### Certifications and approvals

CE Certificate of Constancy of Performance	n° 1812-CPR-1023	Efectis
German approval	n° Z-56.4212-987	DIBt
NF certification	n° 09/04.02	AFNOR
Swiss approval	n° 25971	VKF-AEAI
Swedish approval	n° SC0195-16	SP

### Components

1. Casing made from galvanized carbon steel.
2. Thermal labyrinth
3. Intumescent graphite gasket on the outside the casing
4. Damper blade made from refracting material
5. Blade pivot
6. Cold smoke air seal gasket
7. Intumescent graphite gasket on inside of casing for the hot seal of the blade once closed
8. Temperature controlled closing device (thermal fuse)
9. Blade actioning device
10. Manual closing device (Test button)
11. Manual reset lever
12. Closed blade stopper
13. Protection box
14. Inspection opening Ø 18mm for endoscope (available only for non-motorized version)

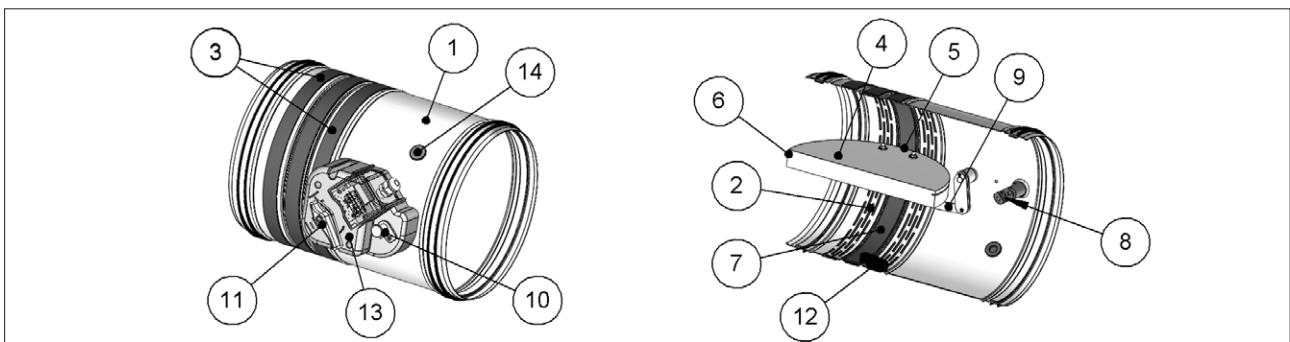

## Available dimensions

Ø	mm	100	125	140	150	160	180	200	224	250	280	300	315
---	----	-----	-----	-----	-----	-----	-----	-----	-----	-----	-----	-----	-----

## Performances

Performance	Reference standard	Class
Thermal fuse testing	ISO 10294-4	Compliant
Open and Close cycle reliability	EN 15650	Compliant
Resistance to corrosion in humid and saline environments	EN 60068-2-52	Degree of severity 2
Casing tightness	EN 1751	Class C
Blade seal	EN 1751	Class 3 minimum

## Fire resistance classification according to EN 13501-3-2009

		EI 120 S (500 Pa)	EI 90 S (500 Pa)	EI 60 S (500 Pa)	EI 30 S (500 Pa)	
<b>Rigid wall</b>	<u>EI 120 S Installation within vertical rigid wall p. 19</u>					
	Wall minimum thickness 100 mm Wall minimum density 550 kg/m <sup>3</sup> Mortar or plaster putty sealing ve (i↔o)	W	Ø min 100 max 315	Ø min 100 max 315	Ø min 100 max 315	Ø min 100 max 315
	<u>EI 90 S Installation within vertical rigid wall p. 19</u>					
	Wall minimum thickness 100 mm Wall minimum density 550 kg/m <sup>3</sup> Plasterboard and rock wool 100 kg/m <sup>3</sup> sealing ve (i↔o)	D	-	Ø min 100 max 315	Ø min 100 max 315	Ø min 100 max 315
<b>Flexible wall</b>	<u>EI 60 S Installation within vertical light wall (plasterboard) p. 21</u>					
	Wall minimum thickness 100 mm Wall rock wool density up to 80 kg/m <sup>3</sup> (optional) Plasterboard and rock wool 80 kg/m <sup>3</sup> density sealing ve (i↔o)	D	-	-	Ø min 100 max 315	Ø min 100 max 315
	<u>EI 90 S Installation within vertical light wall (plasterboard) p. 21</u>					
	Wall minimum thickness 100 mm Wall rock wool density up to 80 kg/m <sup>3</sup> (optional) Plasterboard and rock wool 100 kg/m <sup>3</sup> density sealing ve (i↔o)	D	-	Ø min 100 max 315	Ø min 100 max 315	Ø min 100 max 315
	<u>EI 120 S Installation within vertical light wall (plasterboard) p. 21</u>					
	Wall minimum thickness 100 mm Wall rock wool density up to 80 kg/m <sup>3</sup> (optional) Mortar or plaster putty sealing ve (i↔o)	W	Ø min 100 max 315	Ø min 100 max 315	Ø min 100 max 315	Ø min 100 max 315
	<u>EI 90 S Installation within vertical light wall (gypsum blocks wall) p. 22</u>					
	Wall minimum thickness 70 mm Wall minimum density 995 kg/m <sup>3</sup> Plaster putty sealing ve (i↔o)	W	-	Ø min 100 max 315	Ø min 100 max 315	Ø min 100 max 315
<u>EI 120 S Installation within vertical light wall (gypsum blocks wall) p. 22</u>						
Wall minimum thickness 100 mm Wall minimum density 995 kg/m <sup>3</sup> Plaster putty sealing ve (i↔o)	W	Ø min 100 max 315	Ø min 100 max 315	Ø min 100 max 315	Ø min 100 max 315	

		EI 120 S (500 Pa)	EI 90 S (500 Pa)	EI 60 S (500 Pa)	EI 30 S (500 Pa)
Floor	EI 90 S Installation within floor <a href="#">p. 23</a>				
	Floor minimum thickness 100 mm		∅	∅	∅
	Floor minimum density 650 kg/m <sup>3</sup>		min 100	min 100	min 100
	Mortar sealing ho (i↔o)	W	-	max 315	max 315
Floor	EI 120 S Installation within floor <a href="#">p. 23</a>				
	Floor minimum thickness 150 mm		∅	∅	∅
	Floor minimum density 650 kg/m <sup>3</sup>		min 100	min 100	min 100
	Mortar sealing ho (i↔o)	W	max 315	max 315	max 315

∅ is the minimum and maximum nominal diameter of fire dampers in mm

ve Vertical installation

ho Horizontal installation

(i↔o) Origin of fire irrelevant

Pa Pascal of depression

E Integrity

I Thermal insulation

S Smoke seal

W Wet method sealing

D Dry method sealing

Cert. N° 1812-CPR-1023

#### ▣ Fire Batt (Weichschott) sealings

		EI 120 S (300 Pa)	EI 90 S (300 Pa)	EI 60 S (300 Pa)	EI 30 S (300 Pa)
Rigid wall	EI 120 S Installation within vertical rigid wall with Fire Batt (Weichschott) sealing <a href="#">p. 24</a>				
	Wall minimum thickness 100 mm		∅	∅	∅
	Wall minimum density 550 kg/m <sup>3</sup>		min 100	min 100	min 100
	Rock wool 140 kg/m <sup>3</sup> and endothermic varnish sealing ve (i↔o)	W	max 315	max 315	max 315
Minimum distance allowed between 2 dampers		200 mm	50 mm	50 mm	50 mm
Flexible wall	EI 120 S Installation within vertical light wall (plasterboard) with Fire Batt (Weichschott) sealing <a href="#">p. 24</a>				
	Wall minimum thickness 100 mm		∅	∅	∅
	Wall rock wool density up to 80 kg/m <sup>3</sup> (optional)		min 100	min 100	min 100
	Rock wool density 140 kg/m <sup>3</sup> and endothermic varnish sealing ve (i↔o)	W	max 315	max 315	max 315
Minimum distance allowed between 2 dampers		200 mm	50 mm	50 mm	50 mm
Flexible wall	EI 120 S Installation within vertical light wall (gypsum blocks wall) with Fire Batt (Weichschott) sealing <a href="#">p. 24</a>				
	Wall minimum thickness 100 mm		∅	∅	∅
	Wall minimum density 995 kg/m <sup>3</sup>		min 100	min 100	min 100
	Rock wool 140 kg/m <sup>3</sup> and endothermic varnish sealing ve (i↔o)	W	max 315	max 315	max 315
Minimum distance allowed between 2 dampers		200 mm	50 mm	50 mm	50 mm
Floor	EI 90 S Installation within floor and Fire Batt (Weichschott) sealing <a href="#">p. 25</a>				
	Floor minimum thickness 150 mm		∅	∅	∅
	Floor minimum density 650 kg/m <sup>3</sup>		min 100	min 100	min 100
	Rock wool 140 kg/m <sup>3</sup> and endothermic varnish sealing ho (i↔o)	W	-	max 315	max 315
Minimum distance allowed between 2 dampers		-	200 mm	200 mm	200 mm

#### ▣ Installation remote from construction support

		EI 120 S (300 Pa)	EI 90 S (300 Pa)	EI 60 S (500 Pa)	EI 30 S (500 Pa)
Rigid wall	EI 120 S Installation remote from the vertical rigid wall <a href="#">p. 26</a>				
	Wall minimum thickness 100 mm		∅	∅	∅
	Wall minimum density 550 kg/m <sup>3</sup>		min 100	min 100	min 100
	Mortar or plaster putty sealing ve (i↔o)	W	max 315	max 315	max 315
Rigid wall	EI 120 S Installation remote from the vertical rigid wall with Fire Batt (Weichschott) sealing <a href="#">p. 30</a>				
	Wall minimum thickness 100 mm		∅	∅	∅
	Wall minimum density 550 kg/m <sup>3</sup>		min 100	min 100	min 100
	Rock wool 140 kg/m <sup>3</sup> and endothermic varnish sealing ve (i↔o)	D	max 315	max 315	max 315

		EI 120 S (300 Pa)	EI 90 S (300 Pa)	EI 60 S (500 Pa)	EI 30 S (500 Pa)
Flexible wall	EI 120 S Installation remote from the vertical light wall (plasterboard) <a href="#">p. 28</a>				
	Wall minimum thickness 100 mm	∅	∅	∅	∅
	Wall rock wool density up to 100 kg/m <sup>3</sup> (optional)				
	Plasterboard and rock wool 100 kg/m <sup>3</sup> or mortar or plaster putty sealing ve (i↔o)	D/W min 100 max 315	min 100 max 315	min 100 max 315	min 100 max 315
	EI 120 S Installation remote from the vertical light wall (plasterboard) with Fire Batt (Weichschott) sealing <a href="#">p. 30</a>				
	Wall minimum thickness 100 mm	∅	∅	∅	∅
	Wall rock wool density up to 100 kg/m <sup>3</sup> (optional)				
	Rock wool density 140 kg/m <sup>3</sup> and endothermic varnish sealing ve (i↔o)	D min 100 max 315	min 100 max 315	min 100 max 315	min 100 max 315
Flexible wall	EI 120 S Installation remote from the vertical light wall (gypsum blocks wall) <a href="#">p. 26</a>				
	Wall minimum thickness 100 mm	∅	∅	∅	∅
	Wall minimum density 995 kg/m <sup>3</sup>				
	Mortar or plaster putty sealing ve (i↔o)	W min 100 max 315	min 100 max 315	min 100 max 315	min 100 max 315
Flexible wall	EI 120 S Installation remote from the vertical light wall (gypsum blocks wall) with Fire Batt (Weichschott) sealing <a href="#">p. 30</a>				
	Wall minimum thickness 100 mm	∅	∅	∅	∅
	Wall minimum density 995 kg/m <sup>3</sup>				
	Rock wool 140 kg/m <sup>3</sup> and endothermic varnish sealing ve (i↔o)	D min 100 max 315	min 100 max 315	min 100 max 315	min 100 max 315
Floor	EI 120 S Installation remote from the floor <a href="#">p. 32</a>				
	Floor minimum thickness 150 mm	∅	∅	∅	∅
	Floor minimum density 650 kg/m <sup>3</sup>				
	Mortar or plaster putty sealing ho (i↔o)	W min 100 max 315	min 100 max 315	min 100 max 315	min 100 max 315
Floor	EI 90 S Installation remote from the floor <a href="#">p. 32</a>				
	Floor minimum thickness 100 mm		∅	∅	∅
	Floor minimum density 650 kg/m <sup>3</sup>				
	Mortar or plaster putty sealing ho (i↔o)	W -	min 100 max 315	min 100 max 315	min 100 max 315

▣ Installations within vertical light wall (Shaft wall)

		EI 90 S (300 Pa)	EI 60 S (300 Pa)	EI 30 S (300 Pa)
Flexible wall	EI 90 S Installation within vertical light wall (Shaft wall) <a href="#">p. 34</a>			
	Wall minimum thickness 90 mm		∅	∅
	Plasterboard and mortar or plaster putty sealing ve (i↔o)	W min 100 max 315	min 100 max 315	min 100 max 315

## Mechanism type

### Manual and compact manual

#### Manual

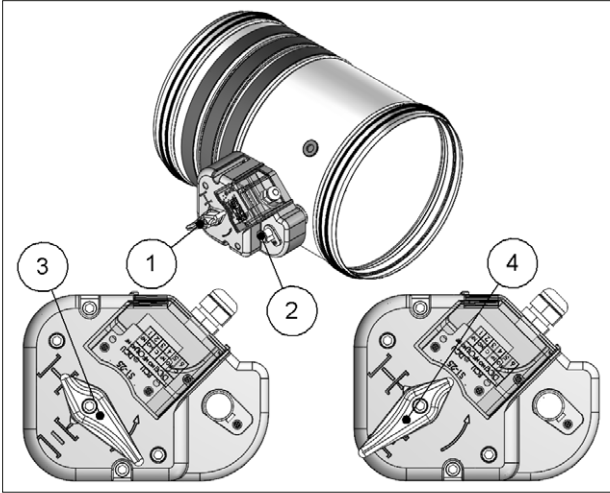

#### Compact manual

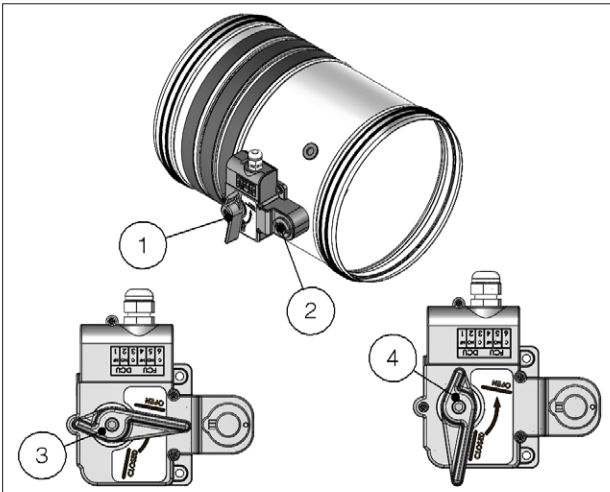

1. Manual opening lever
2. Manual closing button
3. Lever position when the blade is open
4. Lever position when the blade is closed

#### Blade closing mode

Automatic closing with thermal fuse.

The control mechanism has a thermosensitive element that automatically closes the blade when the temperature in the duct exceeds 70°C (or 95°C for the fire damper with 95°C thermal fuse).

It is possible to close the damper by pressing the indicated button.

#### Blade opening mode

The damper must be opened when the ventilation system is switched off.

It is possible to open the damper blade by rotating the lever anticlockwise.

In case of closed damper as a result of the action of the thermosensitive element, it is possible to manually reopen

the damper by rotating the lever counterclockwise once the element has been replaced.

#### Position indication microswitches

On request, the fire damper can be supplied with position microswitches (S2 optional) that signal the blade position (open or closed). Refer to the section Electrical connections p. 35 for more details.

#### Closing by remote control

Not available

#### Temperature calibration of thermosensitive element for automatic damper closing

70 °C±7 °C (Standard)

95 °C±9 °C (On request).

**CAUTION: The compact mechanism is not interchangeable with other types of manual mechanism.**

### Manual with magnet

1. Manual opening lever
2. Manual closing button
3. Lever position when the blade is open
4. Lever position when the blade is closed

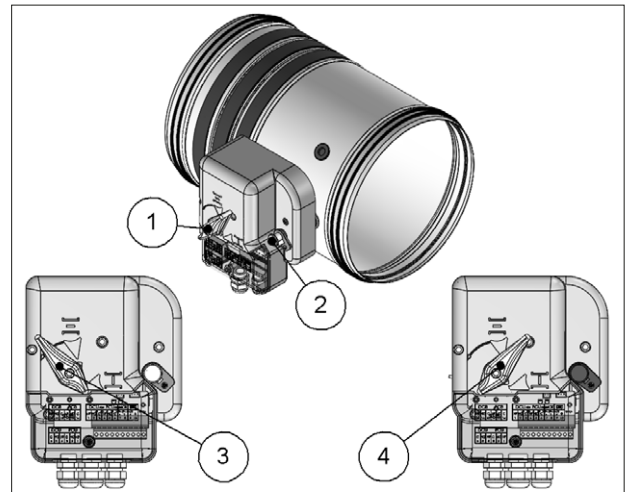

#### Blade closing mode

Automatic closing with thermal fuse.

The control mechanism has a thermosensitive element that automatically closes the blade when the temperature in the duct exceeds 70°C (or 95°C for the fire damper with 95°C thermal fuse).

It is possible to close the damper by pressing the indicated button.

It is possible to remotely close the fire damper.

The manual command mechanism with magnet is equipped with an electromagnet which, in case power is interrupted (interruption magnet version) or when power is supplied (input magnet version), commands the closing of the damper.

#### Blade opening mode

The damper must be opened when the ventilation system is switched off.

In case of closed damper by pressing the closing button or remotely by electromagnet, it is possible to manually open the fire damper blade by rotating the lever anticlockwise.



In case of closed damper as a result of the action of the thermosensitive element, it is possible to manually reopen the damper by rotating the lever counterclockwise once the element has been replaced.

#### Position indication microswitches

It is advisable to install the fire damper with position microswitches (S2 optional) which signal the position of the blade (open or closed). Refer to the section Electrical connections [p. 35](#) for more details.

#### Closing by remote control

With power supply input or interruption magnet.

#### Temperature calibration of thermosensitive element for automatic damper closing

70 °C±7 °C (Standard)

95 °C±9 °C (On request).

#### ▣ Belimo motorized version

1. Manual closing switch
2. Manual opening lever
3. Position indicator
4. Blade locking lever

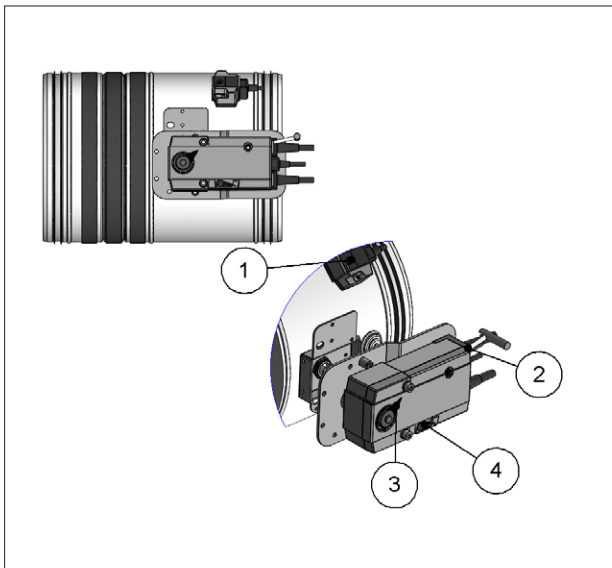

#### Blade closing mode

Automatic closing with thermal fuse.

The control mechanism has a thermosensitive element that automatically closes the blade when the temperature in the duct or in the room exceeds 72°C (or 95°C for the 95°C version).

To close the damper when the motor is connected, press the switch on the temperature sensor or cut off the power supply.

#### Blade opening mode

The damper must be opened when the ventilation system is switched off.

To open the damper with the electric motor driven actuator, provide power supply to the motor. Refer to the section Electrical connections [p. 35](#) for further information.

To manually open the damper, use the handle supplied and carefully rotate clockwise to the 90° indicator. To hold the damper in open position operate on the lever indicated in figure.

During the manual opening of the damper, power must not be supplied to the motor.

#### Position indication microswitches

The motorized versions are supplied with two microswitches to show the blade's position (open or closed). Refer to the section Electrical connections [p. 35](#) for further information.

#### Closing by remote control

If power to the motor is cut off, the blade will close.

#### Temperature calibration of thermosensitive element for automatic damper closing

72 °C±7 °C (Standard)

95 °C±9 °C (On request).

#### ▣ Siemens motorized version

1. Manual closing switch
2. Manual opening lever
3. Screwdriver
4. Position indicator

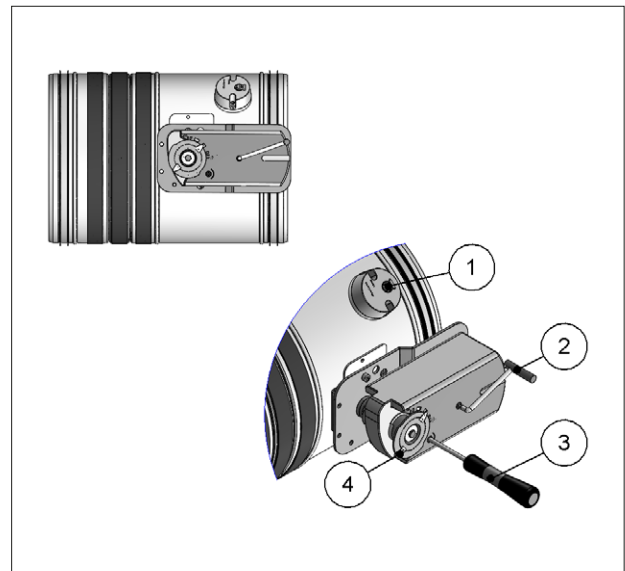

#### Blade closing mode

Automatic closing with thermal fuse.

The control mechanism has a thermosensitive element that automatically closes the blade when the temperature in the duct or in the room exceeds 72°C (or 95°C for the 95°C version).

To close the damper when the motor is connected, press the switch on the temperature sensor or cut off the power supply.

#### Blade opening mode

The damper must be opened when the ventilation system is switched off.

To open the damper with the electric motor driven actuator, provide power supply to the motor. Refer to the section Electrical connections [p. 35](#) for further information.

To manually open the damper, use the handle supplied and carefully rotate counterclockwise to the 90° indicator. To hold the damper in open position, rotate the screw anticlockwise as shown in the picture.

During the manual opening of the damper, power must not be supplied to the motor.

**Position indication microswitches**

The motorized versions are supplied with two microswitches to show the blade's position (open or closed). Refer to the section Electrical connections [p. 35](#) for further information.

**Closing by remote control**

If power to the motor is cut off, the blade will close.

**Temperature calibration of thermosensitive element for automatic damper closing**

72 °C±7 °C (Standard)

95 °C±9 °C (On request).

# TECHNICAL DATA

The sizes shown are in mm.

## Dimension

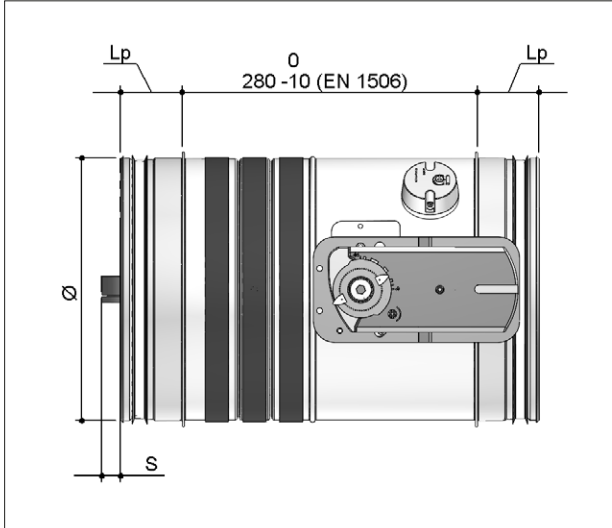

Lp Overlap length between fire damper and duct

Ø	mm	100	125	140	150	160	180
S blade exposition	mm	0	0	0	0	0	0
Lp	mm	38	38	38	38	38	38

Ø	mm	200	224	250	280	300	315
S blade exposition	mm	0	1	0	10	20	28
Lp	mm	38	38	57	57	57	57

## Manual

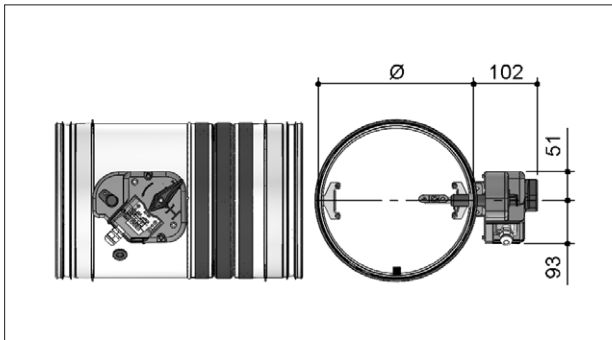

## Siemens motorized version

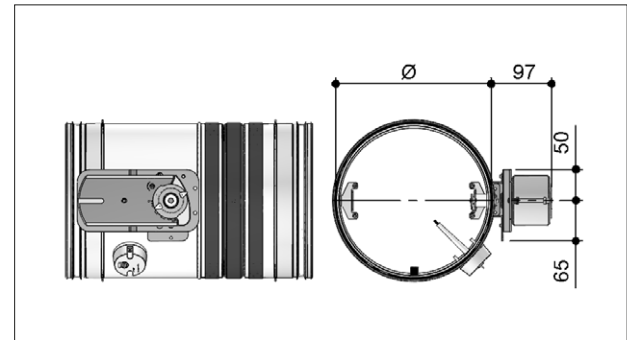

## Manual with magnet

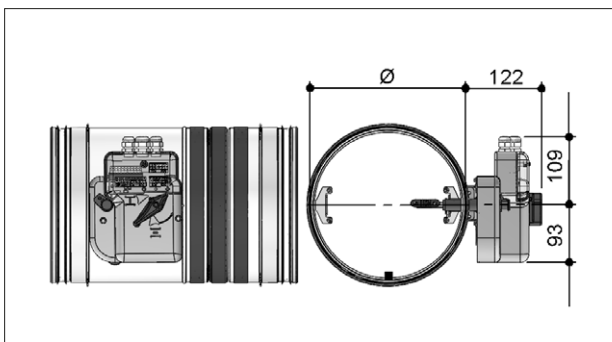

## Belimo motorized version

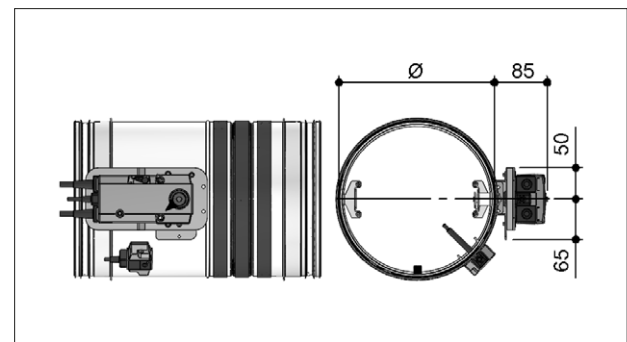

## Weights

Ø	mm	100	125	140	150	160	180	200	224	250	280	300	315
Weight	kg	2,6	2,7	2,8	2,9	3,0	3,2	3,5	4,0	4,5	5,0	5,6	5,9

Manual version. Motorized version: +1 kg

# INSTALLATION

The sizes shown are in mm.

## ■ Intended use

The MP3 fire dampers are “Devices for use in heating, ventilation and air conditioning (HVAC) systems at fire boundaries to maintain compartmentation and protect means of escape in case of fire” according to the 3.1 paragraph of EN 15650:2010 standard.

It is compulsory to install the fire damper according to the instructions indicated in the technical data sheet and manual to maintain the declared performances and, in particular, the fire classes.

The double test (with the mechanism inside and outside the fire area) demonstrated that there is no preferred direction for the position of the damper, both in relation to air flow and the side with the higher probability of exposure to fire, as indicated in standard EN1366-2:2015 (paragraph 6.2).

Use permitted in any civil and industrial building.

Use permitted in saline atmosphere, for example:

- maritime and port environments;
- fish markets;
- slaughterhouses;
- cheese makers.

## ■ Not allowed uses

- Use with installations different to those described in the technical data sheet and manual;
- use as smoke control damper;
- use as shut off damper;
- use in external environments without adequate protection from atmospheric conditions;
- use in explosive environments;
- use on board of ships;
- use in cooker extraction hoods;
- use in pneumatic conveying systems of dust or corn;
- use in ventilation systems within locations subject to chemical contamination;
- use in non inspectable environments.
- Installation in suspended ceilings.

## ■ Positioning brackets before fixing

1. Positioning brackets

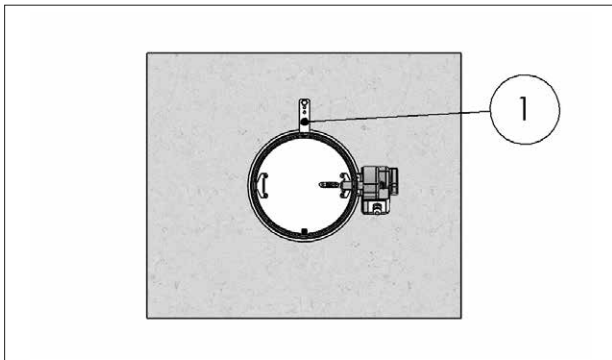

## ■ Blade rotation axis positioning

The fire damper can be installed with the blade axis positioned vertically or horizontally or tilted at any angle.

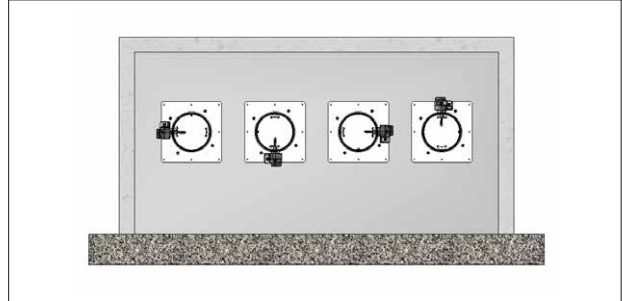

## ■ Installation of flexible connectors in order to balance out the ventilation ducts expansion

**CAUTION: Refer anyway to law and national standardization.**

Flexible connectors compensate any duct thermal expansion and wall bending in case of fire.

Flexible connectors are used to limit fire damper stresses due to external forces in case of fire and to preserve fire resistance class.

In general it is always appropriate the use of flexible connectors for the followings installations:

- light walls;
- Plasterboard and rock wool or Fire Batt (Weichschott) sealing;
- Applique fixing system.

Flexible connector must be normal flammability and in case of fire the grounding bonding should disconnect to guarantee the complete separation between fire damper and connected air duct.

When flexible connectors made of conductive material (e.g. aluminum) are used, no additional grounding bonding is required.

Despite flexible connector installation, the fire damper must be installed in the construction support so that its weight does not affect damper's installation position both during normal operation and in case of fire.

It is recommended not to compress flexible connectors in the installation phase.

Flexible connector must be at least 100mm long and in order that possible duct thermal expansions are balanced. Take care that the flexible connector does not interfere with opening / closing movement of the blade.

Refer to the section Technical data [p. 11](#) for blade exposition values.

## ■ Transfer Application (application not connected to air ducts on one or both sides)

Following tests performed as per EN 1366-2, section 6.3.6 Standard, it is possible to install the fire damper free from air duct from one or both sides.

- Attention: fire resistance classification for transfer application is conform to section Fire resistance classification according to EN 13501-3-2009 p. 5 limited to EI 120S if the ducted classification is higher.
- End cap with mesh shall be mounted on the side not connected to air duct.
- End cap with mesh is made from galvanized steel sheet.
- End cap with mesh is supplied loose from the fire damper.
- Refer to the section How to order (transfer Application) p. 14 for codes to use.

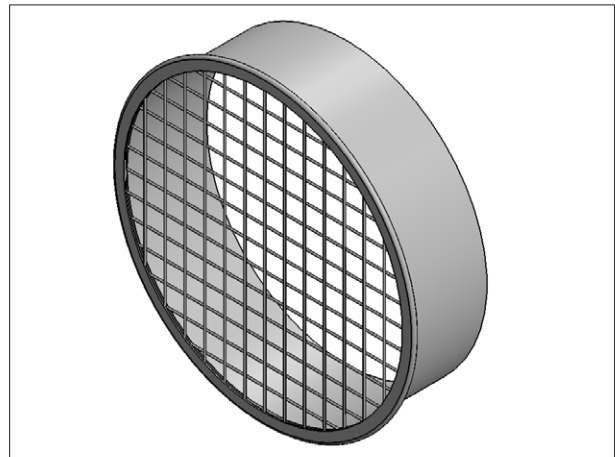

## ■ Components (Transfer Application)

1. End cap with mesh (to fix to fire damper with steel screws)

2. Fire damper

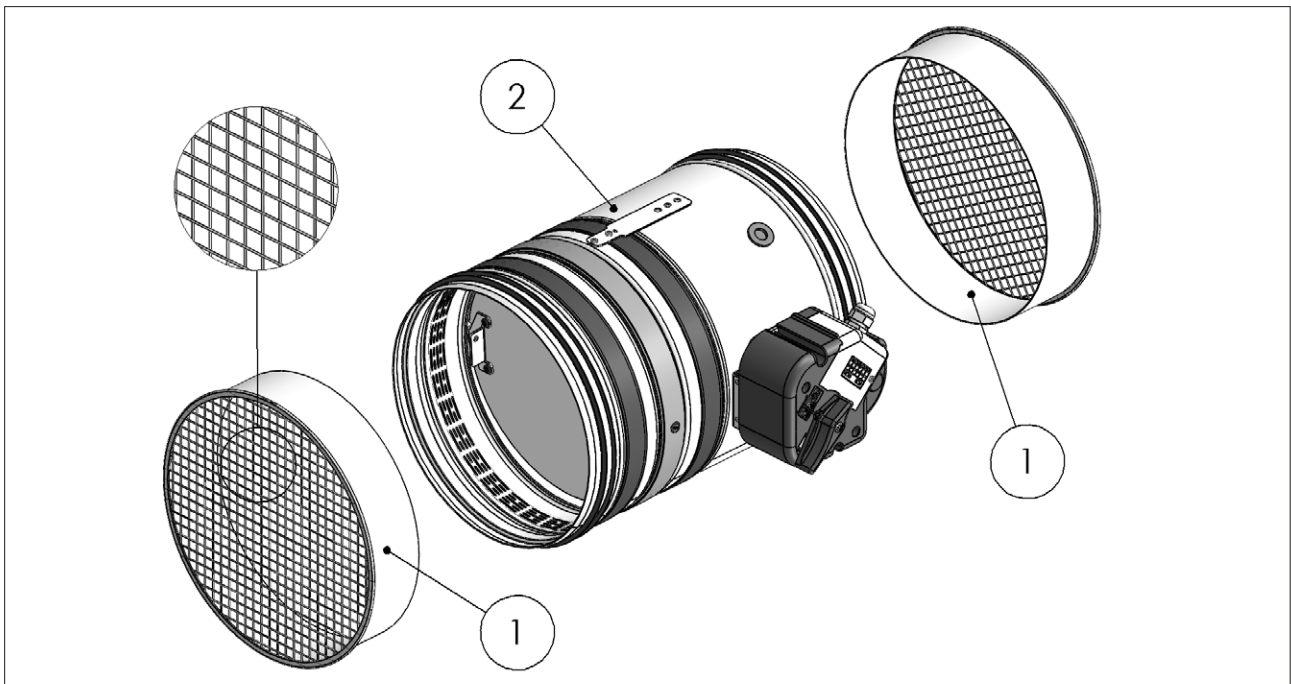

Technical data (Transfer Application)

- |    |                         |    |  |
|----|-------------------------|----|--|
| 1. | Mechanism side          | L1 | End cap length mechanism side          |
| 2. | Mechanism opposite side | L2 | End cap length mechanism opposite side |
| 3. | End cap with mesh       | Ø  | Fire damper nominal diameter           |

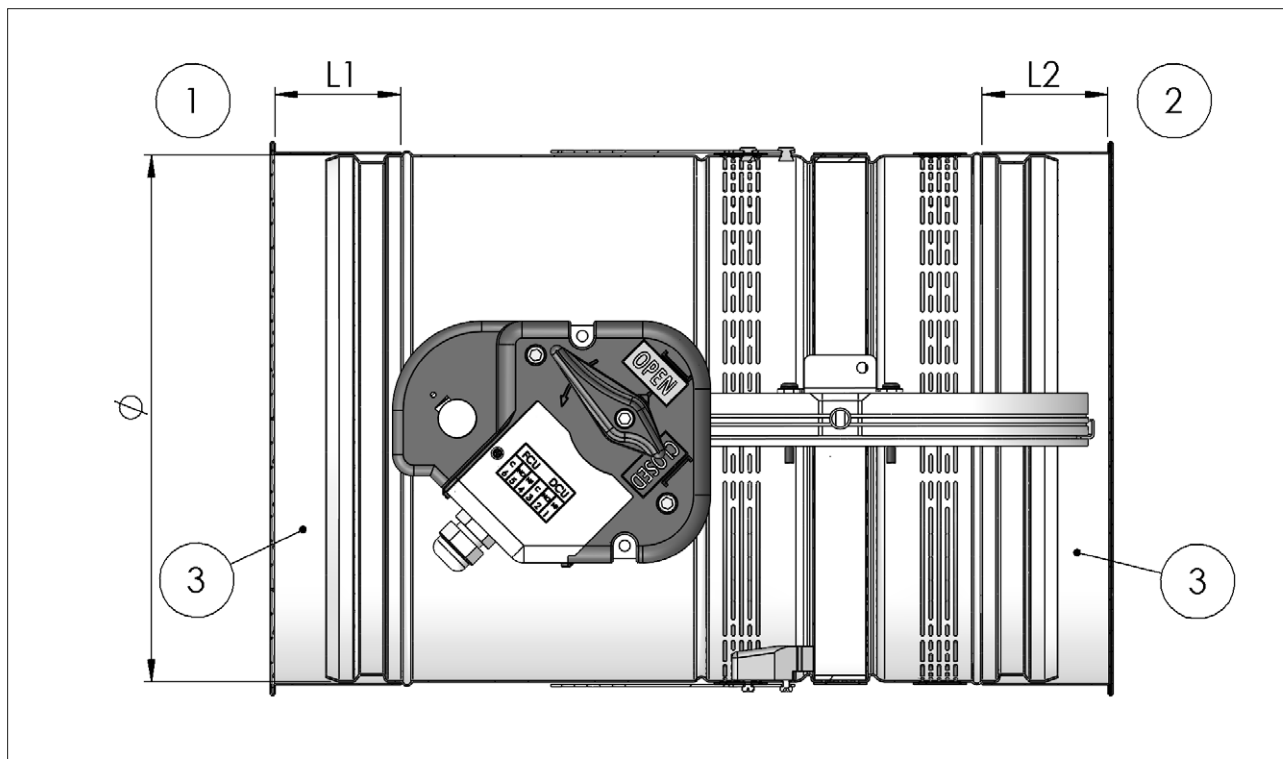

Length of end cap with mesh depending on fire damper diameter Ø.

Ø	L1	L2
100	40	40
125	40	40
140	40	40
150	40	40
160	40	40
180	40	40
200	40	60
224	40	40
250	60	80
280	60	100
300	60	100
315	60	120

- Ø Fire damper nominal diameter  
L1 End cap length mechanism side  
L2 End cap length mechanism opposite side

How to order (transfer Application)

Code	Type	EPNF	End cap with mesh
Diameter		XYZ	Nominal diameter dimension (mm)
Length		XYZ	Length dimension (mm)

Examples	Code
End cap with mesh length 80 mm for fire damper Ø100 not connected to air ducts on mechanism side	EPNF10040
End cap with mesh length 60 mm for fire damper Ø200 not connected to air ducts on mechanism opposite side	EPNF20060
End caps with mesh length 60 mm (mechanism side) and length 120 mm (mechanism opposite side) with mesh for fire damper Ø315 not connected to air ducts on both sides	EPNF31560 EPNF315120

## Minimum distances

It is recommended to keep enough space for using the control mechanism or for maintenance.

In accordance with Articles 7 and 13 of EN 1366-2 respect the minimum distances indicated below.

### Minimum distances

- |    |  |    |  |
|----|--|----|--|
| 1. | Side vertical wall   | b. | Distance between fire damper and vertical lateral wall / floor |
| 2. | Floor  | c. | Distance between fire dampers installed within floor           |
| a. | Distance between fire dampers installed within vertical wall | d. | Distance between fire damper and vertical lateral wall         |

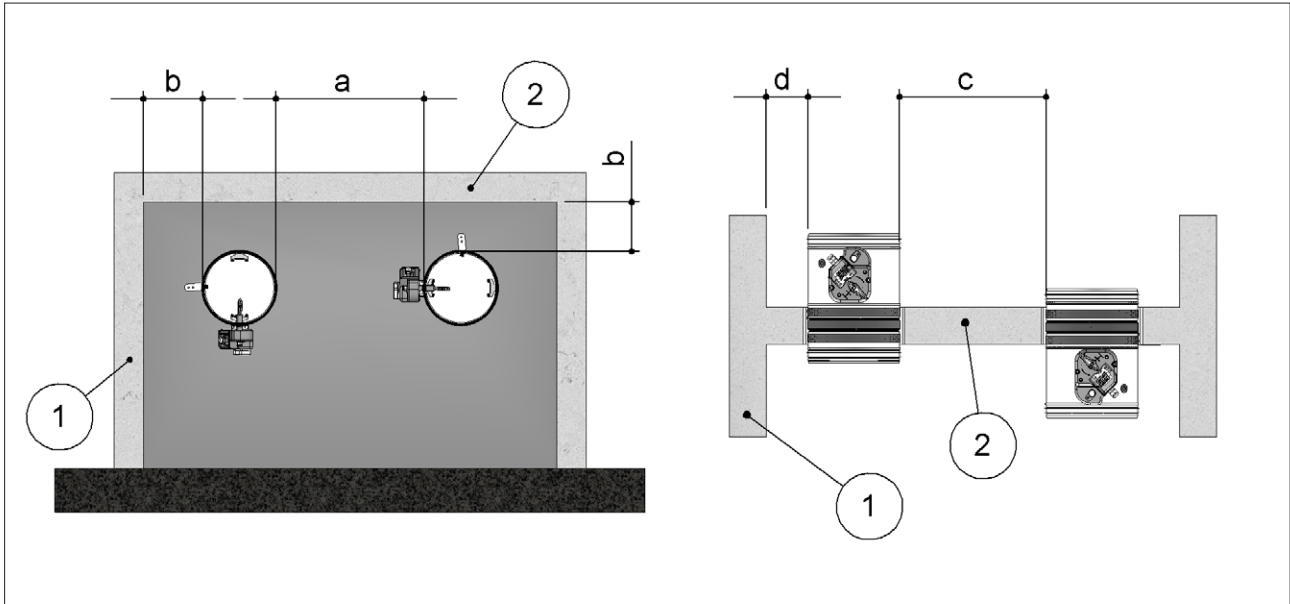

		Fire dampers installed within vertical wall		Fire dampers installed within floor	
	Installation	a [mm]	b [mm]	c [mm]	d [mm]
<b>Rigid wall</b>	EI 120 S Installation within vertical rigid wall <a href="#">p. 19</a> Mortar or plaster putty sealing	50	75	-	-
	EI 90 S Installation within vertical rigid wall <a href="#">p. 19</a> Plasterboard and rock wool 100 kg/m <sup>3</sup> sealing	50	75	-	-
<b>Flexible wall</b>	EI 120 S Installation within vertical light wall (plasterboard) <a href="#">p. 21</a> Mortar or plaster putty sealing	50	75	-	-
	EI 90 S Installation within vertical light wall (plasterboard) <a href="#">p. 21</a> Plasterboard and rock wool 100 kg/m <sup>3</sup> sealing	50	75	-	-
	EI 60 S Installation within vertical light wall (plasterboard) <a href="#">p. 21</a> Plasterboard and rock wool 80 kg/m <sup>3</sup> sealing	50	75	-	-
	EI 120 S Installation within vertical light wall (gypsum blocks wall) <a href="#">p. 22</a> Plaster putty sealing	50	75	-	-
	EI 90 S Installation within vertical light wall (gypsum blocks wall) <a href="#">p. 22</a> Plaster putty sealing	50	75	-	-
<b>Floor</b>	EI 120 S Installation within floor <a href="#">p. 23</a> Mortar sealing	-	-	50	75
	EI 90 S Installation within floor <a href="#">p. 23</a> Mortar sealing	-	-	50	75

▣ Fire Batt (Weichschott) sealings

	Installation	Fire dampers installed within vertical wall		Fire dampers installed within floor	
		a [mm]	b [mm]	c [mm]	d [mm]
Rigid wall	EI 120 S Installation within vertical rigid wall with Fire Batt (Weichschott) sealing <a href="#">p. 24</a> Rock wool 140 kg/m <sup>3</sup> and endothermic varnish sealing	50 *	50	-	-
	EI 120 S Installation within vertical light wall (plasterboard) with Fire Batt (Weichschott) sealing <a href="#">p. 24</a> Rock wool 140 kg/m <sup>3</sup> and endothermic varnish sealing	50 *	50	-	-
Flexible wall	EI 120 S Installation within vertical light wall (gypsum blocks wall) with Fire Batt (Weichschott) sealing <a href="#">p. 24</a> Rock wool 140 kg/m <sup>3</sup> and endothermic varnish sealing	50 *	50	-	-
Floor	EI 90 S Installation within floor and Fire Batt (Weichschott) sealing <a href="#">p. 25</a> Rock wool 140 kg/m <sup>3</sup> and endothermic varnish sealing	-	-	200	75

\* For the distance **a** including between 50 mm and 200 mm the fire resistance class is reduced to EI 90 S

▣ Installation remote from construction support

	Installation	Fire dampers installed within vertical wall		Fire dampers installed within floor	
		a [mm]	b [mm]	c [mm]	d [mm]
Rigid wall	Installation remote from the vertical rigid wall <a href="#">p. 26</a> Mortar or plaster putty sealing	200	110 *	-	-
	Installation remote from the vertical rigid wall with Fire Batt (Weichschott) sealing <a href="#">p. 30</a> Rock wool 140 kg/m <sup>3</sup> and endothermic varnish sealing	200	110 *	-	-
Flexible wall	Installation remote from vertical light wall (plasterboard) <a href="#">p. 28</a> Plasterboard and rock wool 100 kg/m <sup>3</sup> or mortar or plaster putty sealing	200	110 *	-	-
	Installation remote from the vertical light wall (plasterboard) with Fire Batt (Weichschott) sealing <a href="#">p. 30</a> Rock wool 140 kg/m <sup>3</sup> and endothermic varnish sealing	200	110 *	-	-
	Installation remote from the vertical light wall (gypsum blocks wall) <a href="#">p. 26</a> Mortar or plaster putty sealing	200	110 *	-	-
	Installation remote from the vertical light wall (gypsum blocks wall) with Fire Batt (Weichschott) sealing <a href="#">p. 30</a> Rock wool 140 kg/m <sup>3</sup> and endothermic varnish sealing	200	110 *	-	-
Floor	EI 120 S Installation remote from the floor <a href="#">p. 32</a> Mortar or plaster putty sealing	-	-	200	110 *
	EI 90 S Installation remote from the floor <a href="#">p. 32</a> Mortar or plaster putty sealing	-	-	200	110 *

\* Due to rock wool panels thickness. See installation details.

▣ Installations within vertical light wall (Shaft wall)

Installation	Fire dampers installed within vertical wall		Fire dampers installed within floor	
	a [mm]	b [mm]	c [mm]	d [mm]
EI 90 S Installation within vertical light wall (Shaft wall) <a href="#">p. 34</a> Plasterboard and mortar or plaster putty sealing	50	75	-	-



## Construction supports characteristics

The European standard for fire dampers foresees a precise correlation between the wall/floor characteristics and the fire resistance class obtained, as well as the correlation between wall/floor used for the test and wall/floor used for the actual installation.

The test results obtained on a type of wall/floor are valid also for walls/floor of the same type but with greater thickness and/or density than those used in the test.

For plasterboard walls, the test results are also valid for walls with a greater number of plasterboard layers on each side. As a result, the indicated thickness and density characteristics are to be considered as minimum values.

The wall/floor in which the fire dampers are installed must be fire class certified according to the standards foreseen for the structure.

### Rigid walls

Can be made with aerated concrete blocks, poured concrete, concrete panels, perforated cell elements in concrete or brick in accordance with the following characteristics:

- minimum thickness 100 mm;
- minimum density 550 kg/m<sup>3</sup>.

The use of a reinforcing beam above the opening is recommended for walls made from concrete blocks, bricks or in concrete cell elements.

For walls built with perforated elements, it is also recommended that the area of the opening be made from full elements (for example aerated concrete blocks) to guarantee the correct adhesion of the mortar.

#### 1. Reinforcing beam

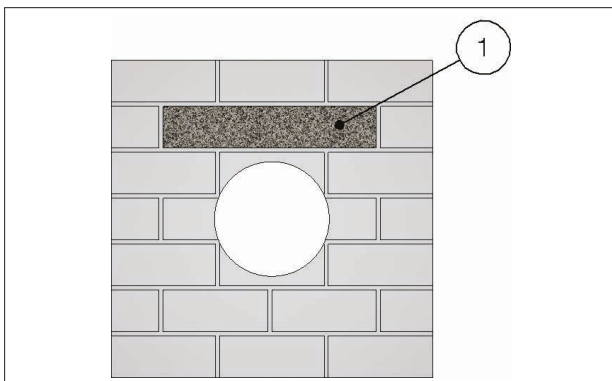

### Light plasterboard vertical walls

During testing, light plasterboard walls have been used with the following characteristics:

- U-shaped horizontal metal frame (50 mm) and C-shaped vertical frame (49 mm) made from 0,6 mm thick sheet metal;
- Vertical profiles placed with a maximum spacing of 625 mm between each other;
- Rock wool filling which has density 80 kg/m<sup>3</sup>;
- Each side is made from two plasterboard layers 12,5 mm thick, unalined to avoid alignment between the joints of the layer above and below.

The following indications are given for the installation walls:

- metal profiles minimum width: 49 mm;
- metal profiles minimum thickness: 0,6 mm;

- vertical profiles placed with a maximum spacing of 625 mm between each other;
- vertical profile fixing with selfthreading screws or by clinching to the bottom horizontal profile and insertion in the top horizontal profile;
- profiles fixed using self-threading screws or by clinching on every intersection.
- installation of a frame around the damper with base and height where shown in the installation instructions;
- rock wool filling which has minimum density 80 kg/m<sup>3</sup>;
- each side is made from two plasterboard layers 12,5 mm minimum thick, unalined to avoid alignment between the joints of the layer above and below.
- the front plasterboards layers are fixed using long enough screws to pass through the lower plasterboard and attach to the steel profile underneath.

1. Plasterboard thickness 12,5 mm
2. Rock wool density up to 80 kg/m<sup>3</sup> (optional)
3. Horizontal U-shaped profile
4. Vertical C-shaped profile
5. Self-drilling screw Ø 3,5 X 25 mm
6. Self-drilling screw Ø 3,5 X 35 mm

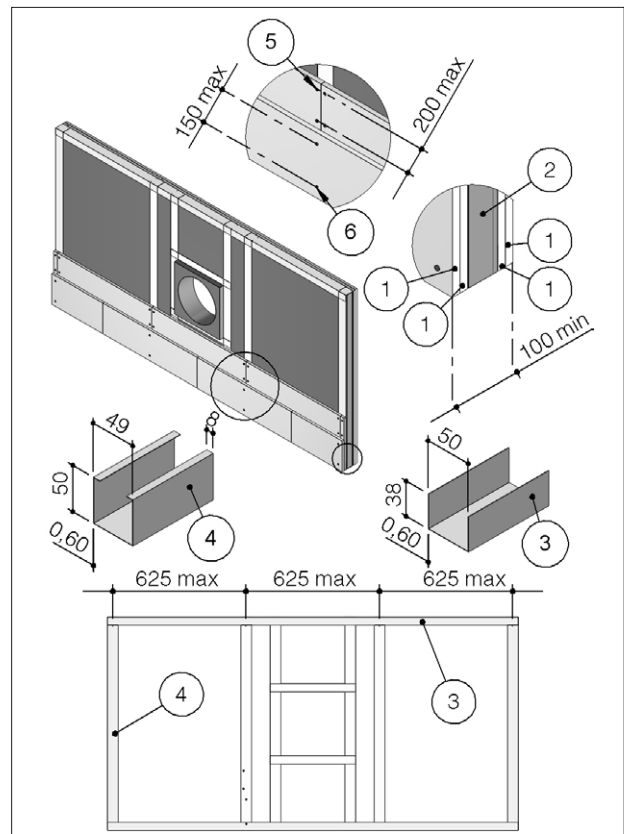

#### ▣ Gypsum blocks light walls

Gypsum blocks wall can be built with special solid gypsum blocks with interlocking shaped edges as indicated in the supplier's instructions and according to the following characteristics:

- minimum thickness 70 or 100 mm according to the type and resistance class required;
- minimum density 995 kg/m<sup>3</sup>.

It is generally advisable to first build the wall and then provide the opening for the fire damper.

#### ▣ Aerated concrete floors

Aerated concrete floors can be built during installation or with preformed slabs with interlocking shaped edges according to the following characteristics:

- minimum thickness 100 or 150 mm according to the type and resistance class required;
- minimum density 650 kg/m<sup>3</sup>

#### ▣ Poured concrete floors

Poured concrete floors can be built during installation or with preformed slabs with interlocking shaped edges according to the following characteristics:

- minimum thickness 100 or 150 mm according to the resistance class required;
- minimum density 2200 kg/m<sup>3</sup>.

## ■ Installations within vertical rigid wall

Refer to the section Construction supports characteristics [p. 17](#) for further information.

Comply with the minimum distances indicated on section Minimum distances [p. 15](#).

### ■ Wall opening

A opening must be provided in the wall as indicated in the table and in the drawing

### ■ Damper positioning

Position the damper in the opening so that the side of the closing mechanism extends as indicated in the drawing.

### ■ Filling

Fill the space between the wall and the damper as indicated in the table and in the drawing.

	Fire resistance classification	"D" hole size [mm]	Wall minimum thickness "S" [mm]	Sealing
<b>EI 120 S Installation within vertical rigid wall</b>				
Wall minimum density 550 kg/m <sup>3</sup>	EI 120 S (500 Pa)	From Ø + 25 to Ø + 440 (circular hole)	100	Mortar or plaster putty sealing
<b>EI 90 S Installation within vertical rigid wall</b>				
Wall minimum density 550 kg/m <sup>3</sup>	EI 90 S (500 Pa)	From (Ø + 50) x (Ø + 50) To (Ø + 70) x (Ø + 70) (square hole)	100	Rock wool 100 kg/m <sup>3</sup> with infill plasterboard (thickness 12.5 mm)

**EI 120 S Installation within vertical rigid wall**

- |    |  |   |                            |
|----|--|---|----------------------------|
| 1. | Mortar M-10, EN998-2 or plaster putty  | D | Hole size: see table above |
| Lp | Overlap length between fire damper and duct: see section<br>Dimension <u>p. 11</u> |   |                            |

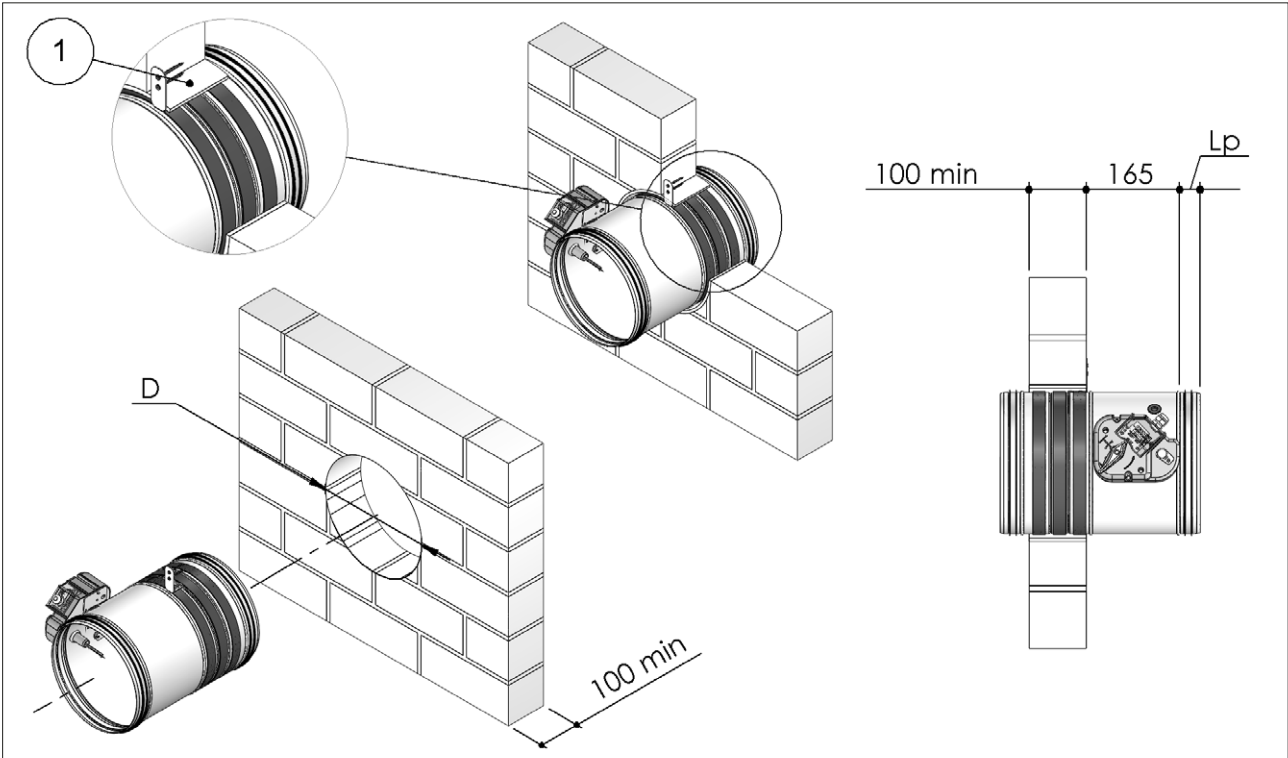

**EI 90 S Installation within vertical rigid wall**

- |    |  |    |  |
|----|--|----|--|
| 1. | Plasterboard infill panel, thickness 12,5 mm       | Lp | Overlap length between fire damper and duct: see section<br>Dimension <u>p. 11</u> |
| 2. | Rock wool, 100 kg/m <sup>3</sup>                   | D  | Hole size: see table above   |
| 3. | Self-drilling screw $\varnothing 3,5 \times 45$ mm |    |  |

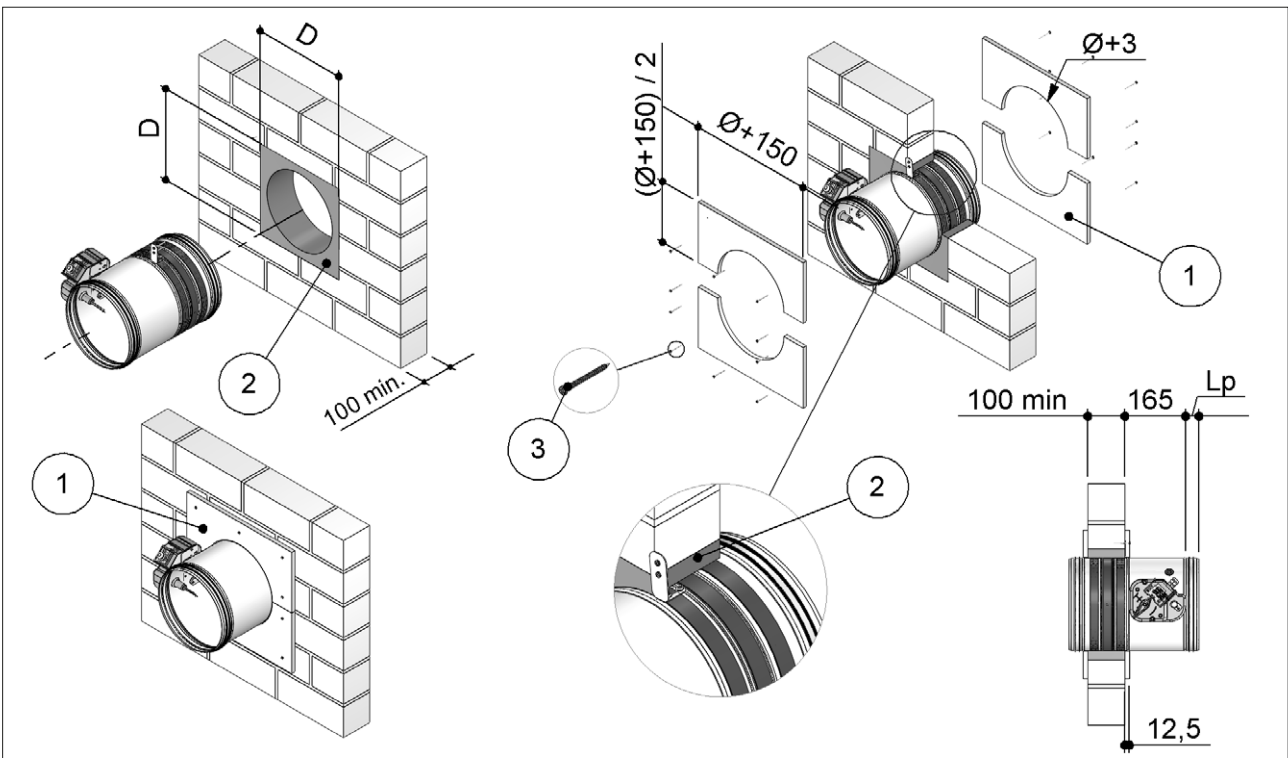

## ■ Installations within vertical light wall (plasterboard)

Refer to the section Construction supports characteristics [p. 17](#) for further information.

Comply with the minimum distances indicated on section Minimum distances [p. 15](#).

### ■ Wall opening

A opening must be provided in the wall as indicated in the table and in the drawing

### ■ Damper positioning

Position the damper in the opening so that the side of the closing mechanism extends as indicated in the drawing.

### ■ Filling

Fill the space between the wall and the damper as indicated in the table and in the drawing.

	Fire resistance classification	"D" hole size [mm]	Wall minimum thickness "S" [mm]	Sealing
<b>EI 60 S Installation within vertical light wall (plasterboard)</b>				
Wall rock wool density up to 80 kg/m <sup>3</sup> (optional)	EI 60 S (500 Pa)	From (Ø + 50) x (Ø + 50) To (Ø + 70) x (Ø + 70) (square hole)	100	Rock wool 80 kg/m <sup>3</sup> with infill plasterboard (thickness 12.5 mm)
<b>EI 90 S Installation within vertical light wall (plasterboard)</b>				
Wall rock wool density up to 80 kg/m <sup>3</sup> (optional)	EI 90 S (500 Pa)	From (Ø + 50) x (Ø + 50) To (Ø + 70) x (Ø + 70) (square hole)	100	Rock wool 100 kg/m <sup>3</sup> with infill plasterboard (thickness 12.5 mm)
<b>EI 120 S Installation within vertical light wall (plasterboard)</b>				
Wall rock wool density up to 80 kg/m <sup>3</sup> (optional)	EI 120 S (500 Pa)	From (Ø + 50) x (Ø + 50) to (Ø + 440) x (Ø + 440) (square hole)	100	Mortar or plaster putty

- |  |   |
|--|---|
| 1. Rock wool density up to 80 kg/m <sup>3</sup> (optional)           | 6. Metal frame  |
| 2. Plasterboard arch infill, thickness 12,5 mm for rock wool sealing | Lp Overlap length between fire damper and duct: see section Dimension <a href="#">p. 11</a> |
| 3. Plasterboard thickness 12,5 mm                                    | D Hole size: see table above  |
| 4. Sealing: see table above  |   |
| 5. Self-drilling screw Ø 3,5 X 45 mm                                 |   |

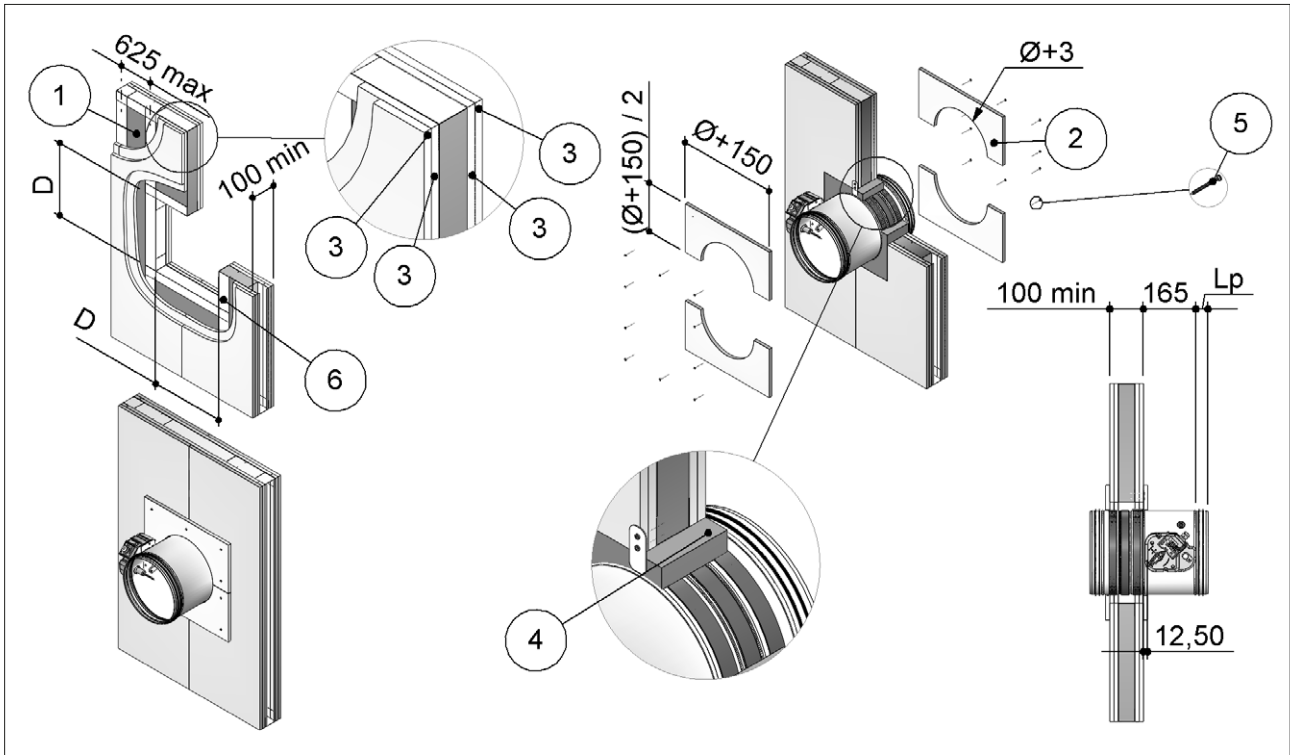

### ■ Installations within vertical light wall (gypsum blocks wall)

Refer to the section Construction supports characteristics [p. 17](#) for further information.  
Comply with the minimum distances indicated on section Minimum distances [p. 15](#).

#### ■ Wall opening

A opening must be provided in the wall as indicated in the table and in the drawing

#### ■ Damper positioning

Position the damper in the opening so that the side of the closing mechanism extends as indicated in the drawing.

#### ■ Filling

Fill the space between the wall and the damper as indicated in the table and in the drawing.

	Fire resistance classification	"D" hole size [mm]	Wall minimum thickness "S" [mm]	Sealing
<b>EI 120 S Installation within vertical light wall (gypsum blocks wall)</b>				
Wall minimum density 995 kg/m <sup>3</sup>	EI 120 S (500 Pa)	From Ø + 25 to Ø + 35 (circular hole)	70	Plaster putty sealing
<b>EI 90 S Installation within vertical light wall (gypsum blocks wall)</b>				
Wall minimum density 995 kg/m <sup>3</sup>	EI 90 S (500 Pa)	From Ø + 25 to Ø + 35 (circular hole)	100	Plaster putty sealing

- 1. Plaster putty
- D Hole size: see table above
- S Wall minimum thickness: see table above

Lp Overlap length between fire damper and duct: see section Dimension [p. 11](#)

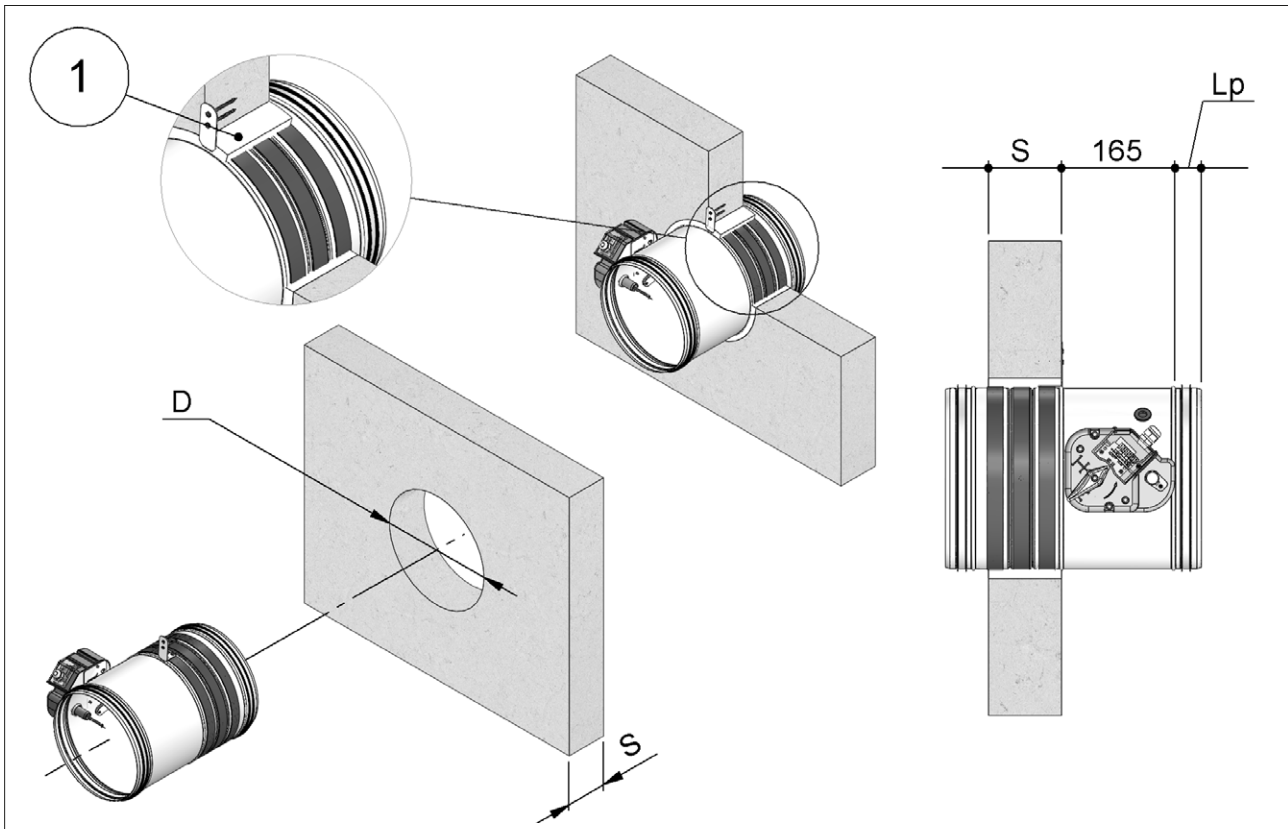

## ■ Installations within floor

Refer to the section Construction supports characteristics [p. 17](#) for further information.  
Comply with the minimum distances indicated on section Minimum distances [p. 15](#).

### ■ Floor opening

A opening must be provided in the floor as indicated in the table and in the drawing

### ■ Damper positioning

Position the damper in the opening so that the side of the closing mechanism extends as indicated in the drawing.

### ■ Filling

Fill the space between the floor and the damper as indicated in the table and in the drawing.

	Fire resistance classification	"D" hole size [mm]	Floor minimum thickness "S" [mm]	Sealing
<b>EI 120 S Installation within floor</b>				
Floor minimum density 650 kg/m <sup>3</sup>	EI 120 S (500 Pa)	From $\emptyset + 25$ to $\emptyset + 35$ (circular hole)	150	Mortar sealing
<b>EI 90 S Installation within floor</b>				
Floor minimum density 650 kg/m <sup>3</sup>	EI 90 S (500 Pa)	From $\emptyset + 25$ to $\emptyset + 35$ (circular hole)	100	Mortar sealing

- 1. Mortar M-10, EN998-2
- D Hole size: see table above
- S Floor minimum thickness: see table above

- Lp Overlap length between fire damper and duct: see section Dimension [p. 11](#)

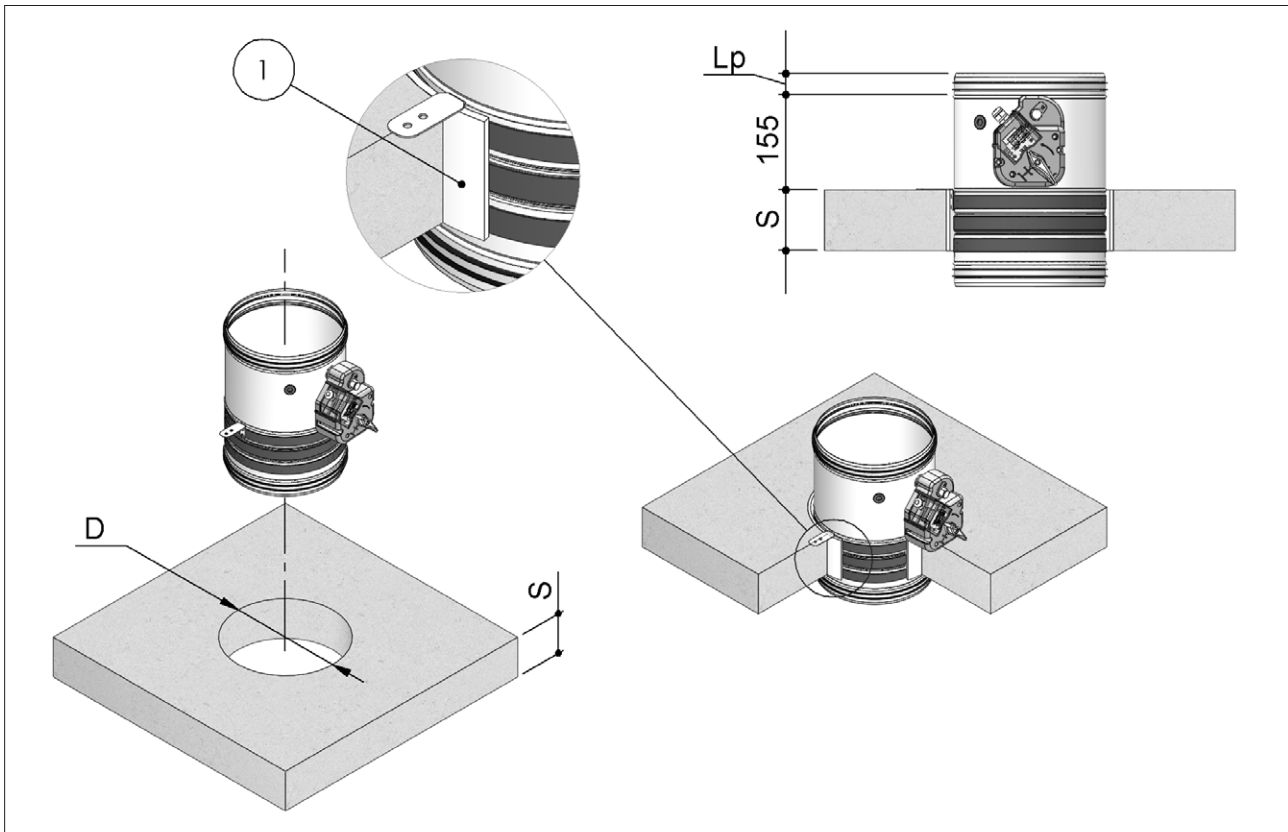



## ■ Installations within vertical wall with Fire Batt (Weichschott) sealing

Refer to the section Construction supports characteristics [p. 17](#) for further information.  
Comply with the minimum distances indicated on section Minimum distances [p. 15](#).

### ■ Wall opening

A opening must be provided in the wall as indicated in the table and in the drawing

### ■ Damper positioning

Position the damper in the opening so that the side of the closing mechanism extends as indicated in the drawing.

The fire damper has to be fixed at the bottom and suspended from the ceiling.

### ■ Filling

Fill the space between the damper and the wall using Fire Batt (Weichschott) sealing made from two rock wool panels with minimum thickness of 50 mm and minimum density of 140 kg/m<sup>3</sup>.

The panels must be covered on both faces of the wall with endothermic varnish type PROMASTOP E PASTE or HILTI CFS-CT (minimum thickness of 1 mm) and with an internal perimeter sealant type PROMASTOP E PASTE or HILTI CFS-S ACR (minimum thickness of 1 mm).

	Fire resistance classification	"D" hole size [mm]	Wall minimum thickness "S" [mm]	Sealing
<b>Rigid wall</b>	<b>EI 120 S Installation within rigid vertical wall with Fire Batt (Weichschott) sealing</b>			
	Wall minimum density 550 kg/m <sup>3</sup>	EI 120 S (300 Pa)	(Ø + 600 max) x (Ø + 600 max) (rectangular hole)	100
<b>Flexible wall</b>	<b>EI 120 S Installation within vertical light wall (plasterboard) with Fire Batt (Weichschott) sealing</b>			
	Wall rock wool density up to 80 kg/m <sup>3</sup> (optional)	EI 120 S (300 Pa)	(Ø + 600 max) x (Ø + 600 max) (rectangular hole)	100
<b>Flexible wall</b>	<b>EI 120 S Installation within vertical light wall (gypsum blocks) with Fire Batt (Weichschott) sealing</b>			
	Wall minimum density 995 kg/m <sup>3</sup>	EI 120 S (300 Pa)	(Ø + 600 max) x (Ø + 600 max) (rectangular hole)	100

1. Rock wool panel 50 mm thick with 140 kg/m<sup>3</sup> density.
2. PROMASTOP E PASTE or HILTI CFS-S ACR type sealant
3. PROMASTOP E PASTE or HILTI CFS-CT endothermic varnish
4. Wall indicated in the table

- Lp Overlap length between fire damper and duct: see section Dimension [p. 11](#)  
D Hole size: see table above  
S Wall minimum thickness: see table above

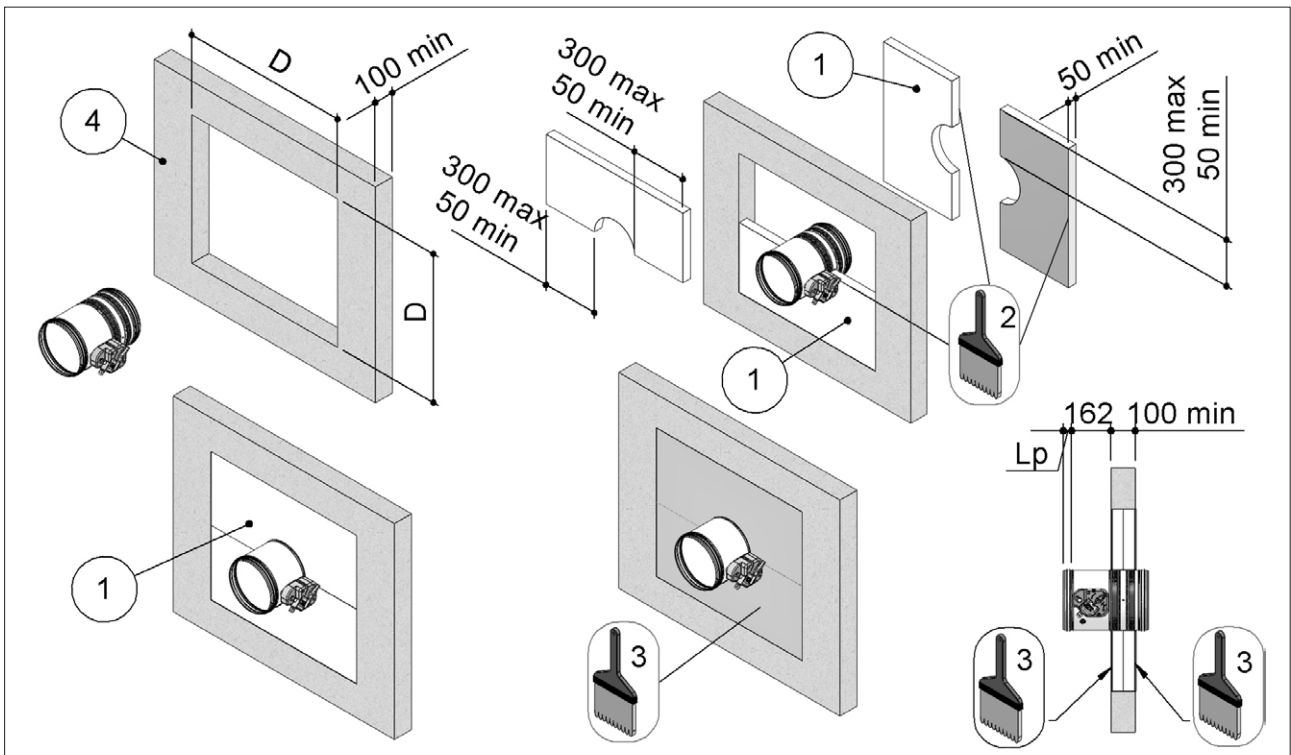



## ■ Installation within floor with Fire Batt (Weichschott) sealing

Refer to the section Construction supports characteristics p.17 for further information.

Comply with the minimum distances indicated on section Minimum distances p.15.

### ■ Floor opening

A opening must be provided in the floor as indicated in the table and in the drawing

### ■ Damper positioning

Position the damper in the opening so that the side of the closing mechanism extends as indicated in the drawing.

The mechanism can be located both above and below the floor.

### ■ Filling

Fill the space between the damper and the floor using Fire Batt (Weichschott) sealing made from two rock wool panels with minimum thickness of 50 mm and minimum density of 140 kg/m<sup>3</sup>.

The panels must be covered on both faces of the wall with endothermic varnish type PROMASTOP E PASTE or HILTI CFS-CT (minimum thickness of 1 mm) and with an internal perimeter sealant type PROMASTOP E PASTE or HILTI CFS-S ACR (minimum thickness of 1 mm).

	Fire resistance classification	"D" hole size [mm]	Floor minimum thickness "S" [mm]	Sealing
<b>EI 90 S Installation within floor and Fire Batt (Weichschott) sealing</b>				
Floor minimum density 650 kg/m <sup>3</sup>	EI 90 S (300 Pa)	(Ø + 600 max) x (Ø + 600 max) (rectangular hole)	150	Rock wool 140 kg/m <sup>3</sup> and endothermic varnish sealing

1. Rock wool panel 50 mm thick with 140 kg/m<sup>3</sup> density.
2. PROMASTOP E PASTE or HILTI CFS-S ACR type sealant
3. PROMASTOP E PASTE or HILTI CFS-CT endothermic varnish

- Lp Overlap length between fire damper and duct: see section Dimension p.11  
 D Hole size: see table above  
 S Floor minimum thickness: see table above

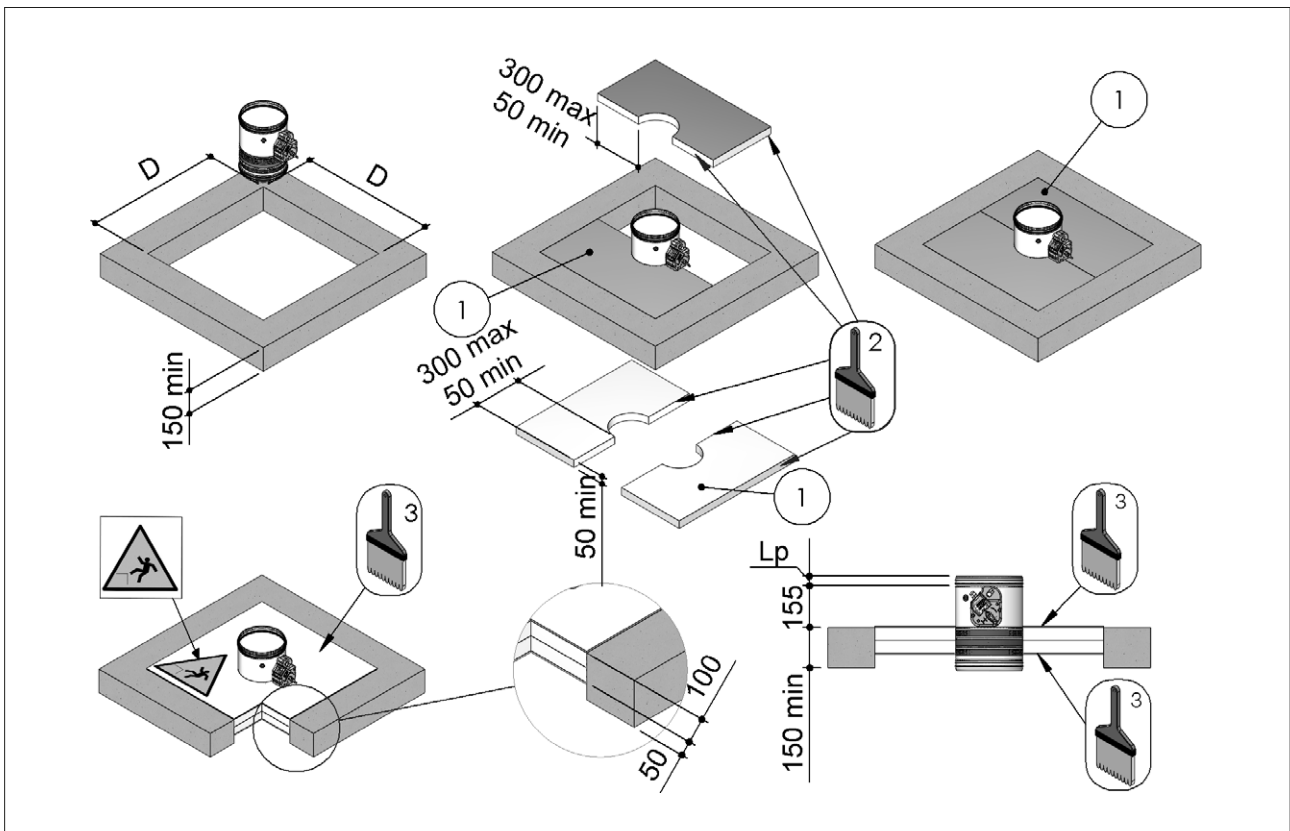

## ■ Installation remote from the vertical rigid wall and the vertical light wall (gypsum blocks wall)

Refer to the section Construction supports characteristics [p. 17](#) for further information.

Comply with the minimum distances indicated on section Minimum distances [p. 15](#).

### ■ Wall opening

A opening must be provided in the wall as indicated in the table and in the drawing

### ■ Damper positioning

Connect fire damper to the galvanized steel duct as indicated in the drawing, with 4 screws Ø4.2x13

Install the damper with the mechanism facing away from the wall as indicated in the drawing.

Between fire damper and wall the maximum distance is 1000 mm.

The maximum length of the part of duct connected to the damper is 2100 mm

The fire damper has to be fixed and suspended from the ceiling as indicated in the drawing.

The hanging structure is composed by:

- 2 C-shaped steel profiles 10x41x41x41x10 mm

- 2 M10 threaded rods

- 4 M10 nuts

Position the threaded rods 1000 mm from the wall and at a distance of 100 mm from the side of the damper.

### ■ Filling

Fill the space between the wall and the damper using mortar suitable for use in fire resistant constructions, M10 class or higher or plaster putty.

Cover the duct over its entire length and fire damper with 2 rock wool panels 50 mm thick and with a density of 140 kg/m<sup>3</sup>.

Fix first layer of rock wool panel to the duct with screws Ø5 X 60 mm and washers 40 X 40 mm, and the second one with screws Ø5 X 120 mm and washers 40 X 40 mm.

Fill the space between rock wool panels and the damper with one rock wool panel with minimum thickness of 50 mm and minimum density of 140 kg/m<sup>3</sup>.

The panels must be covered externally with endothermic varnish type PROSTOP E PASTE or HILTI CFS-CT (minimum thickness of 1 mm) and with an internal perimeter sealant type PROMOSTOP E PASTE or HILTI CFS-S ACR (minimum thickness of 1 mm).

	Fire resistance classification	"D" hole size [mm]	Wall minimum thickness "S" [mm]	Sealing
<b>Rigid wall</b>	<b>Installation remote from the vertical rigid wall</b>			
	Wall minimum density 550 kg/m <sup>3</sup> EI 120 S (300 Pa) EI 90 S (500 Pa)	From Ø + 25 to Ø + 440 (circular hole)	100	Mortar or plaster putty sealing
<b>Flexible wall</b>	<b>Installation remote from the vertical light wall (gypsum blocks wall)</b>			
	Wall minimum density 995 kg/m <sup>3</sup> EI 120 S (300 Pa) EI 90 S (500 Pa)	From Ø + 25 to Ø + 35 (circular hole)	100	Mortar or plaster putty sealing

- D Hole size: see table above
- S Wall minimum thickness: see table above
- 1. Rock wool panel 50 mm thick with 140 kg/m<sup>3</sup> density.
- 2. PROMASTOP E PASTE or HILTI CFS-S ACR type sealant
- 3. PROMASTOP E PASTE or HILTI CFS-CT endothermic varnish
- 4. Vertical wall
- 5. Self-drilling screw Ø 5 X 60 mm
- 6. Self-drilling screw Ø 5 X 120 mm
- 7. Washer 40 x 40 mm
- 8. M10 threaded rod
- 9. C-shaped steel profile 10x41x41x41x10 mm
- 10. M10 nut
- 11. Self-drilling screw Ø 4,2 X 13 mm
- 12. Mortar M-10, EN998-2 or plaster putty

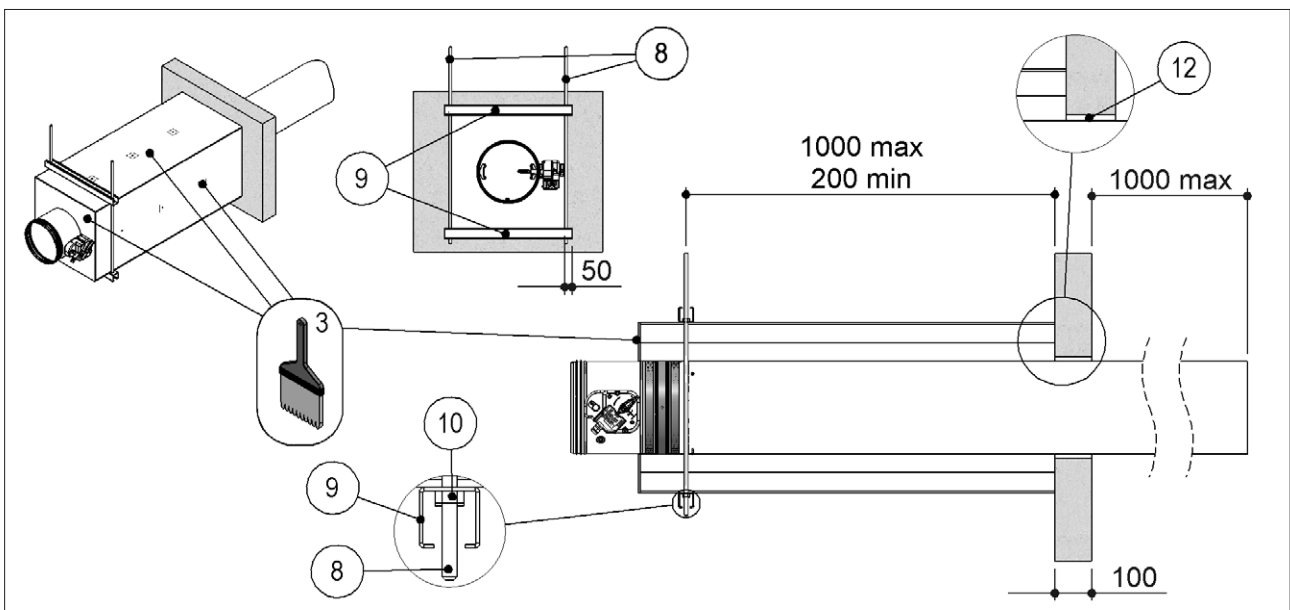
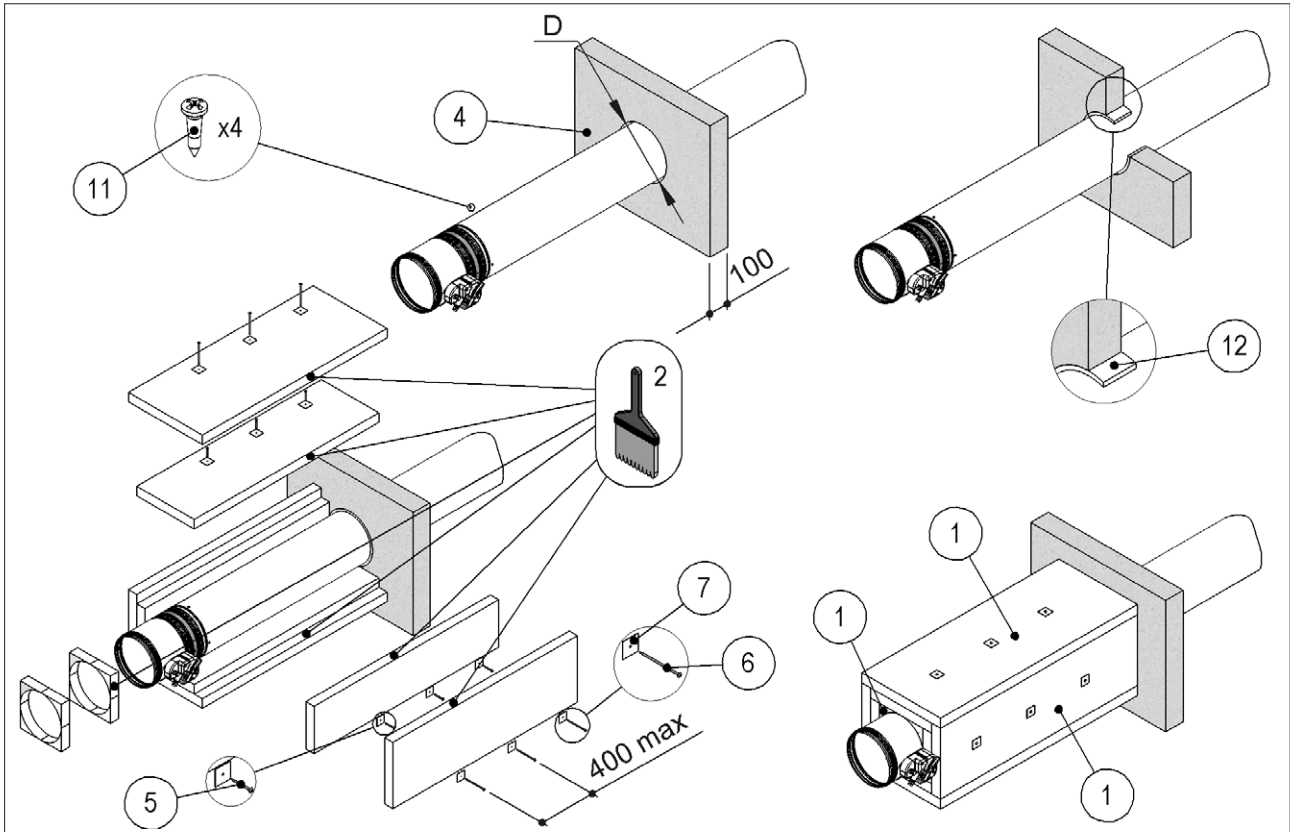

## ■ Installation remote from the vertical light wall (plasterboard)

Refer to the section Construction supports characteristics [p.17](#) for further information.

Comply with the minimum distances indicated on section Minimum distances [p.15](#).

### ■ Wall opening

A opening must be provided in the wall as indicated in the table and in the drawing

### ■ Damper positioning

Connect fire damper to the galvanized steel duct as indicated in the drawing, with 4 screws Ø4.2x13

Install the damper with the mechanism facing away from the wall as indicated in the drawing.

Between fire damper and wall the maximum distance is 1000 mm.

The maximum length of the part of duct connected to the damper is 2100 mm

The fire damper has to be fixed and suspended from the ceiling as indicated in the drawing.

The hanging structure is composed by:

- 2 C-shaped steel profiles 10x41x41x10 mm

- 2 M10 threaded rods

- 4 M10 nuts

Position the threaded rods 1000 mm from the wall and at a distance of 100 mm from the side of the damper.

### ■ Filling

Fill the space between the wall and the fire damper using rock wool which has density of 100 kg/m<sup>3</sup>.

Cover the duct over its entire length and fire damper with 2 rock wool panels 50 mm thick and with a density of 140 kg/m<sup>3</sup>.

Fix first layer of rock wool panel to the duct with screws Ø5 X 60 mm and washers 40 X 40 mm, and the second one with screws Ø5 X 120 mm and washers 40 X 40 mm.

Fill the space between rock wool panels and the the damper with one rock wool panel with minimum thickness of 50 mm and minimum density of 140 kg/m<sup>3</sup>.

The panels must be covered externally with endothermic varnish type PROSTOP E PASTE or HILTI CFS-CT (minimum thickness of 1 mm) and with an internal perimeter sealant type PROMOSTOP E PASTE or HILTI CFS-S ACR (minimum thickness of 1 mm).

	Fire resistance classification	"D" hole size [mm]	Wall minimum thickness "S" [mm]	Sealing
<b>Installation remote from the vertical light wall (plasterboard)</b>				
Wall rock wool density up to 100 kg/m <sup>3</sup> (optional)	EI 120 S (300 Pa) EI 90 S (500 Pa)	From (Ø + 50) x (Ø + 50) To (Ø + 70) x (Ø + 70) (square hole)	100	Rock wool 100 kg/m <sup>3</sup> with infill plasterboard (thickness 12.5 mm)
Wall rock wool density up to 100 kg/m <sup>3</sup> (optional)	EI 120 S (300 Pa) EI 90 S (500 Pa)	From (Ø + 50) x (Ø + 50) to (Ø + 440) x (Ø + 440) (square hole)	100	Mortar or plaster putty

- D Hole size: see table above
- S Wall minimum thickness: see table above
- 1. Rock wool panel 50 mm thick with 140 kg/m<sup>3</sup> density.
- 2. PROMASTOP E PASTE or HILTI CFS-S ACR type sealant
- 3. PROMASTOP E PASTE or HILTI CFS-CT endothermic varnish
- 4. Rock wool, 100 kg/m<sup>3</sup>, or mortar M-10, EN998-2 or plaster putty
- 5. Self-drilling screw Ø 5 X 60 mm
- 6. Self-drilling screw Ø 5 X 120 mm
- 7. Washer 40 x 40 mm
- 8. M10 threaded rod
- 9. C-shaped steel profile 10x41x41x41x10 mm
- 10. M10 nut
- 11. Self-drilling screw Ø 4,2 X 13 mm
- 12. Self-drilling screw Ø 3,5 X 45 mm
- 13. Plasterboard infill panel, thickness 12,5 mm, for rock wool sealing
- 14. Rock wool density up to 80 kg/m<sup>3</sup> (optional)
- 15. Metal frame

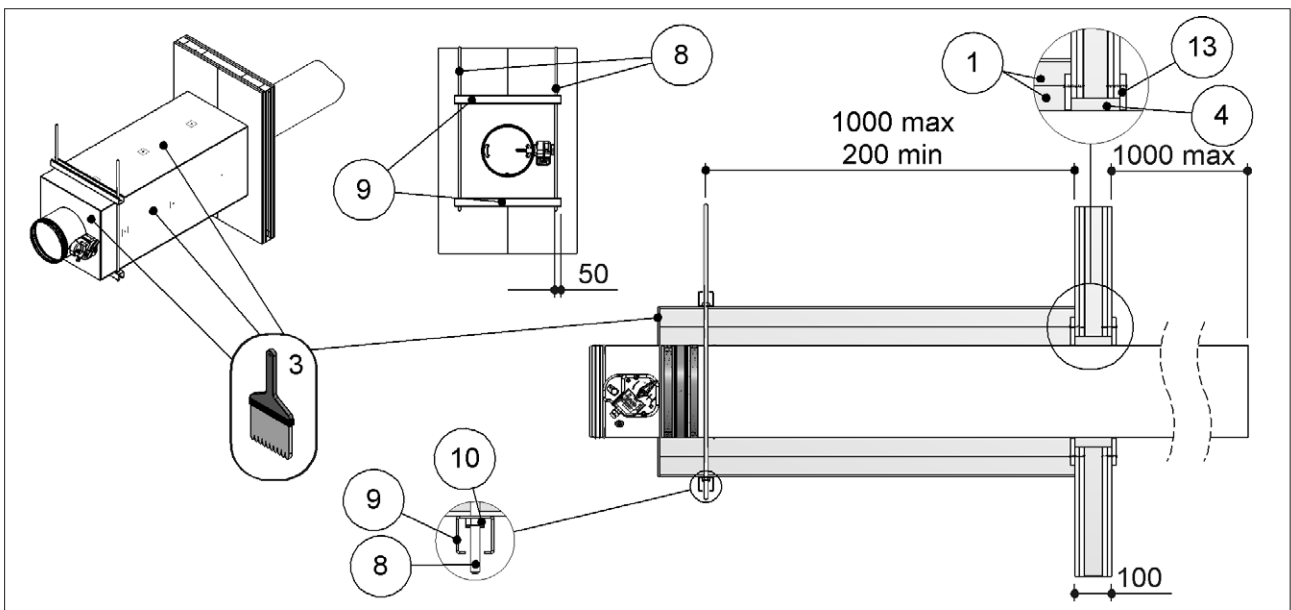
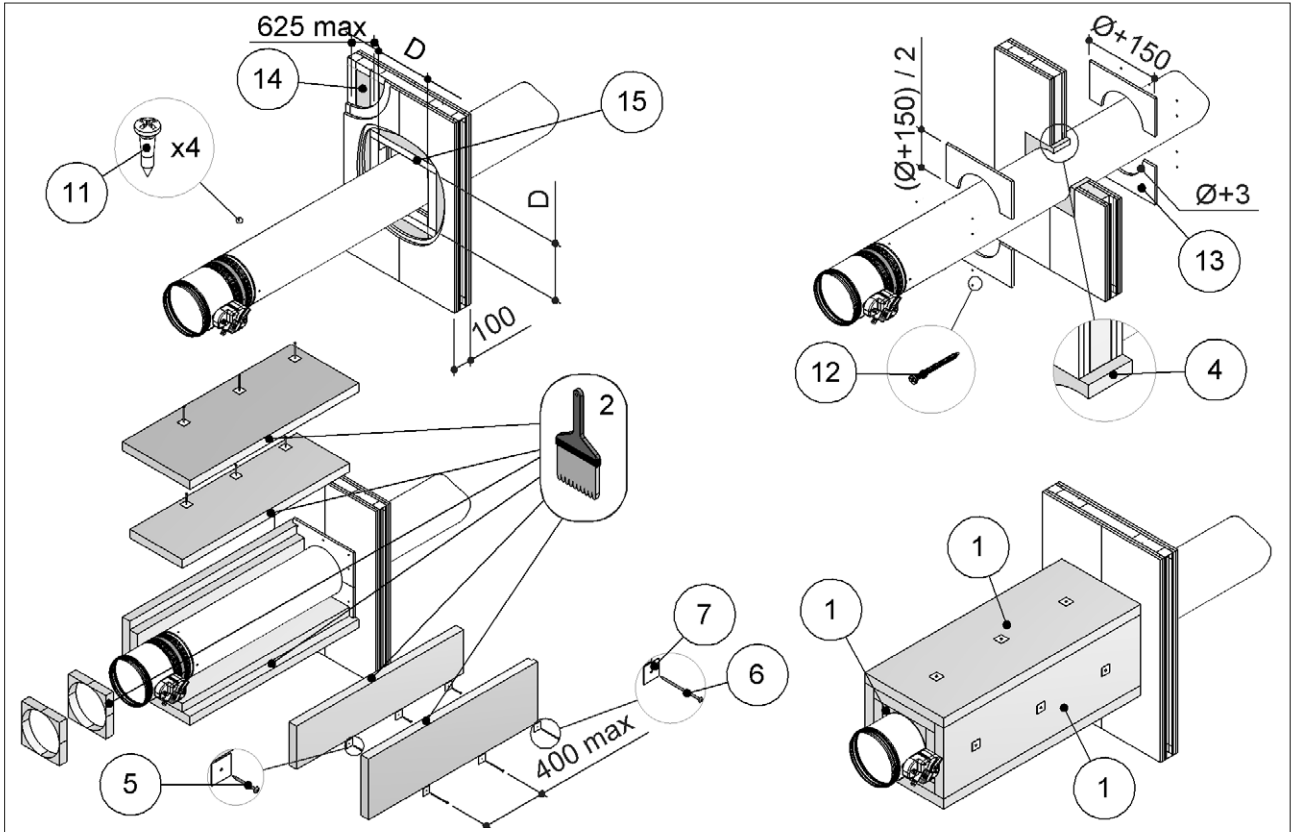

## ■ Installations remote from the vertical wall with Fire Batt (Weichschott) sealing

Refer to the section Construction supports characteristics [p. 17](#) for further information.

Comply with the minimum distances indicated on section Minimum distances [p. 15](#).

### ■ Wall opening

A opening must be provided in the wall as indicated in the table and in the drawing

### ■ Damper positioning

Connect fire damper to the galvanized steel duct as indicated in the drawing, with 4 screws Ø4.2x13

Install the damper with the mechanism facing away from the wall as indicated in the drawing.

Between fire damper and wall the maximum distance is 1000 mm.

The maximum length of the part of duct connected to the damper is 2100 mm

The fire damper has to be fixed and suspended from the ceiling as indicated in the drawing.

The hanging structure is composed by:

- 2 C-shaped steel profiles 10x41x41x10 mm
- 2 M10 threaded rods

- 4 M10 nuts

Position the threaded rods 1000 mm from the wall and at a distance of 100 mm from the side of the damper.

### ■ Filling

Fill the space between the damper and the wall using Fire Batt (Weichschott) sealing made from two rock wool panels with minimum thickness of 50 mm and minimum density of 140 kg/m<sup>3</sup>.

Cover the duct over its entire length and fire damper with 2 rock wool panels 50 mm thick and with a density of 140 kg/m<sup>3</sup>.

Cover first layer of rock wool panel to the duct with screws Ø5 X 60 mm and washers 40 X 40 mm, and the second one with screws Ø5 X 120 mm and washers 40 X 40 mm.

Fill the space between rock wool panels and the damper with one rock wool panel with minimum thickness of 50 mm and minimum density of 140 kg/m<sup>3</sup>.

The panels must be covered externally with endothermic varnish type PROSTOP E PASTE or HILTI CFS-CT (minimum thickness of 1 mm) and with an internal perimeter sealant type PROMOSTOP E PASTE or HILTI CFS-S ACR (minimum thickness of 1 mm).

	Fire resistance classification	"D" hole size [mm]	Wall minimum thickness "S" [mm]	Sealing
<b>Rigid wall</b>	<b>Installation remote from the vertical rigid wall with Fire Batt (Weichschott) sealing</b>			
	Wall minimum density 550 kg/m <sup>3</sup>	EI 120 S (300 Pa) EI 90 S (500 Pa)	(Ø + 600 max) x (Ø + 600 max) (rectangular hole)	100 Rock wool 140 kg/m <sup>3</sup> and endothermic varnish sealing
<b>Flexible wall</b>	<b>Installation remote from vertical light wall (plasterboard) with Fire Batt (Weichschott) sealing</b>			
	Wall rock wool density up to 100 kg/m <sup>3</sup> (optional)	EI 120 S (300 Pa) EI 90 S (500 Pa)	(Ø + 600 max) x (Ø + 600 max) (rectangular hole)	100 Rock wool 140 kg/m <sup>3</sup> and endothermic varnish sealing
	<b>Installation remote from vertical light wall (gypsum blocks) with Fire Batt (Weichschott) sealing</b>			
	Wall minimum density 995 kg/m <sup>3</sup>	EI 120 S (300 Pa) EI 90 S (500 Pa)	(Ø + 600 max) x (Ø + 600 max) (rectangular hole)	100 Rock wool 140 kg/m <sup>3</sup> and endothermic varnish sealing

- D Hole size: see table above
- 1. Rock wool panel 50 mm thick with 140 kg/m<sup>3</sup> density.
- 2. PROMASTOP E PASTE or HILTI CFS-S ACR type sealant
- 3. PROMASTOP E PASTE or HILTI CFS-CT endothermic varnish
- 4. Wall indicated in the table above
- 5. Self-drilling screw Ø 5 X 60 mm
- 6. Self-drilling screw Ø 5 X 120 mm
- 7. Washer 40 x 40 mm
- 8. M10 threaded rod
- 9. C-shaped steel profile 10x41x41x41x10 mm
- 10. M10 nut
- 11. Self-drilling screw Ø 4,2 X 13 mm

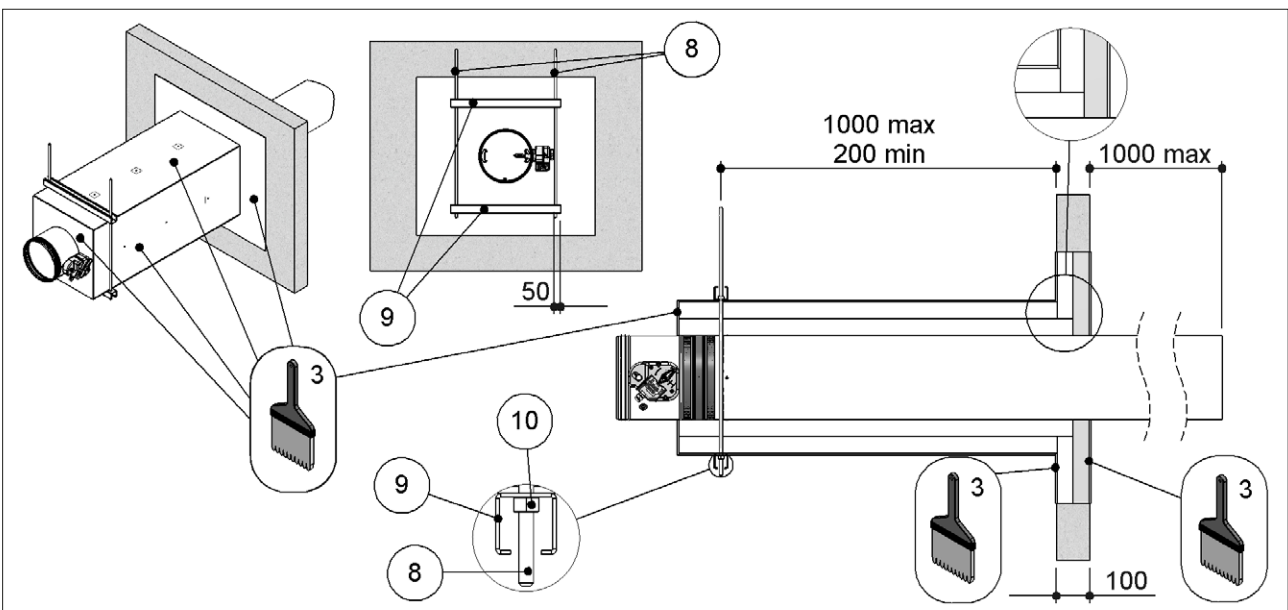
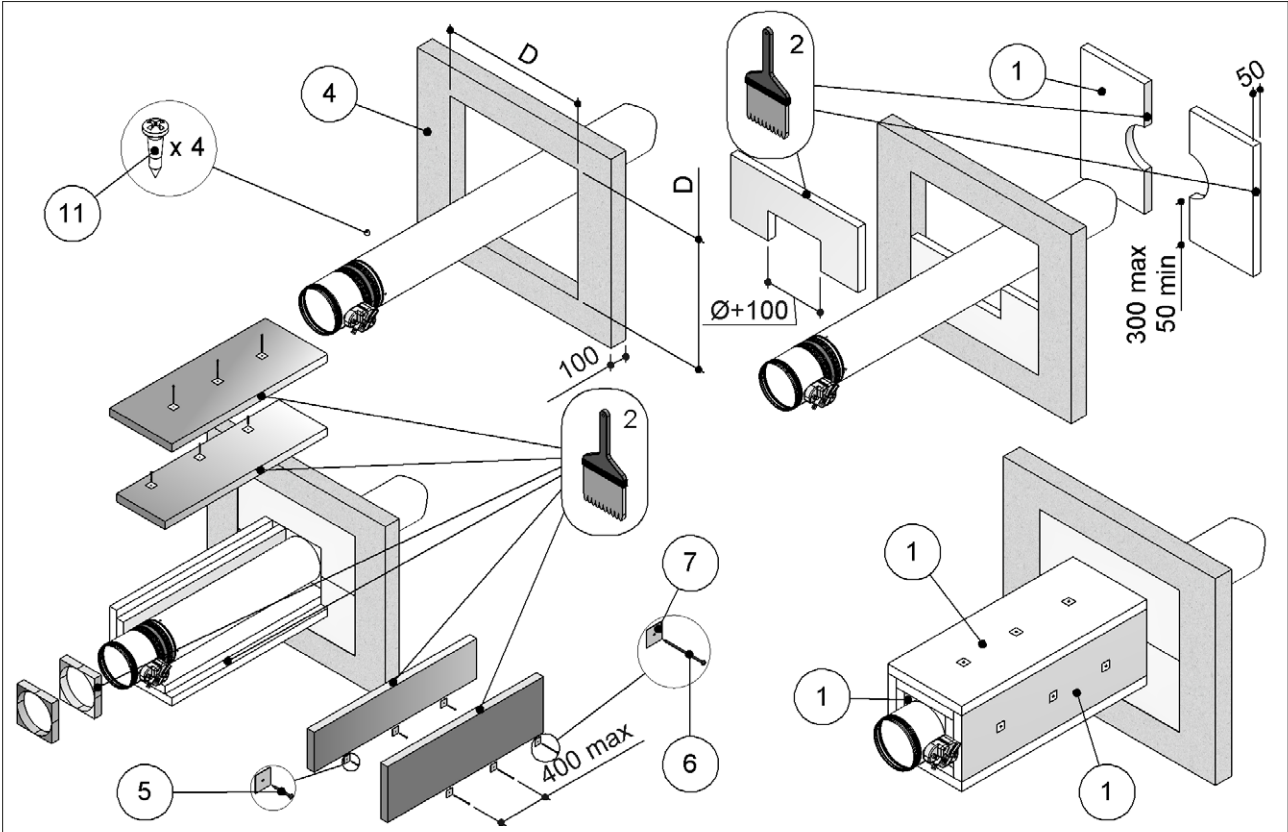



## ■ Installations remote from the floor

Refer to the section Construction supports characteristics p.17 for further information.

Comply with the minimum distances indicated on section Minimum distances p.15.

### ■ Floor opening

A opening must be provided in the floor as indicated in the table and in the drawing

### ■ Damper positioning

Connect fire damper to the galvanized steel duct as indicated in the drawing, with 4 screws Ø4.2x13

Install the damper with the mechanism facing away from the floor as indicated in the drawing.

Between fire damper and floor the maximum distance is 1000 mm.

The maximum length of the part of duct connected to the damper is 2150 mm

The fire damper has to be fixed and suspended from the ceiling as indicated in the drawing.

The fire damper must be positioned just above the floor as indicated in the drawing.

The hanging structure is composed by:

- 4 Angle connectors 105x105x90 mm
- Screws M8 x 40 mm
- Washers 15 x 9 mm
- Flush anchors M8 x 40 mm

### ■ Filling

Fill the space between the floor and the damper using mortar suitable for use in fire resistant constructions, M10 class or higher or plaster putty.

Cover the duct over its entire length and fire damper with 2 rock wool panels 50 mm thick and with a density of 140 kg/m<sup>3</sup>.

Fix first layer of rock wool panel to the duct with screws Ø5 X 60 mm and washers 40 X 40 mm, and the second one with screws Ø5 X 120 mm and washers 40 X 40 mm.

Fill the space between rock wool panels and the the damper with one rock wool panel with minimum thickness of 50 mm and minimum density of 140 kg/m<sup>3</sup>.

The panels must be covered externally with endothermic varnish type PROSTOP E PASTE or HILTI CFS-CT (minimum thickness of 1 mm) and with an internal perimeter sealant type PROMOSTOP E PASTE or HILTI CFS-S ACR (minimum thickness of 1 mm).

	Fire resistance classification	"D" hole size [mm]	Wall minimum thickness "S" [mm]	Sealing
<b>EI 90 S Installation remote from the floor</b>				
Floor minimum density 650 kg/m <sup>3</sup>	EI 90 S (500 Pa)	From Ø + 25 to Ø + 35 (circular hole)	100	Mortar or plaster putty sealing
<b>EI 120 S Installation remote from the floor</b>				
Floor minimum density 650 kg/m <sup>3</sup>	EI 120 S (300 Pa)	From Ø + 25 to Ø + 35 (circular hole)	150	Mortar or plaster putty sealing

**The fire damper must be positioned just above the floor as indicated in the drawing.**

1. Floor
2. Duct
3. Fire damper

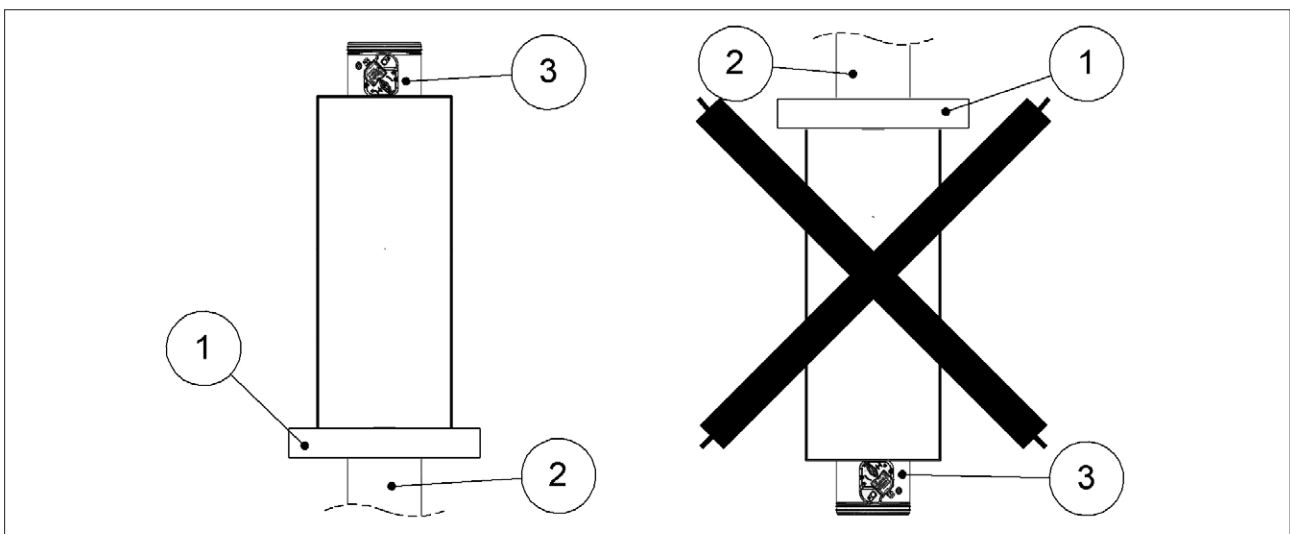



- D Hole size: see table above
- S Wall minimum thickness: see table above
- 1. Self-drilling screw  $\varnothing 4,2 \times 13$  mm
- 2. PROMASTOP E PASTE or HILTI CFS-S ACR type sealant
- 3. PROMASTOP E PASTE or HILTI CFS-CT endothermic varnish
- 4. Screws M8 x 40 mm
- 5. Washers 15 x 9 mm
- 6. Angle connector 105 X 105 X 90 mm
- 7. Washers 15 x 5 mm
- 8. Mortar M-10, EN998-2 or plaster putty
- 9. Washer 40 x 40 mm
- 10. Self-drilling screw  $\varnothing 5 \times 60$  mm
- 11. Self-drilling screw  $\varnothing 5 \times 120$  mm
- 12. Rock wool panel 50 mm thick with 140 kg/m<sup>3</sup> density.
- 13. Flush anchors M8 x 40 mm
- 14. Floor

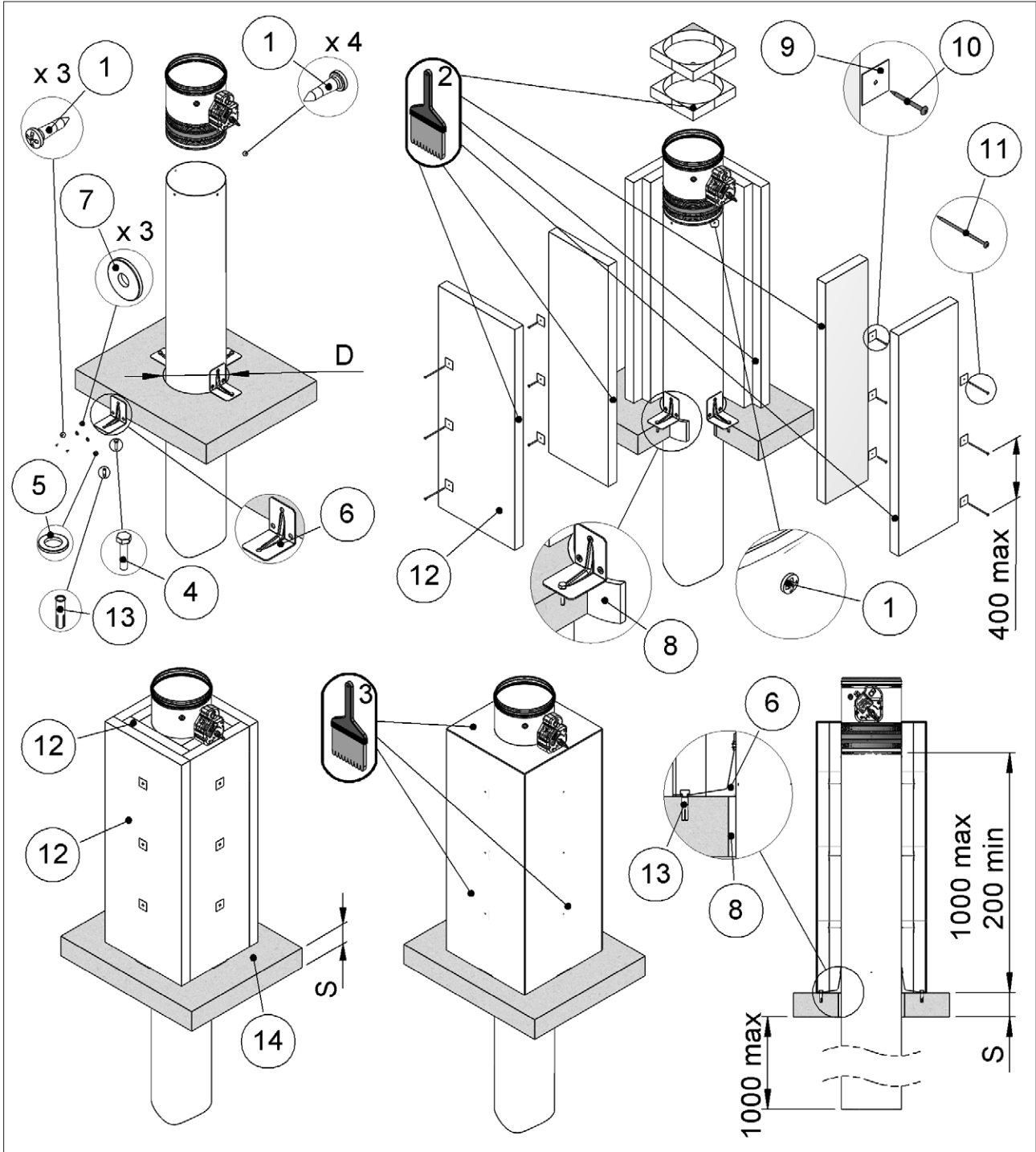

## ■ Installation within vertical light wall (Shaft wall)

Refer to the section Construction supports characteristics [p.17](#) for further information.

Comply with the minimum distances indicated on section Minimum distances [p.15](#).

### ■ Wall opening

A opening must be provided in the wall as indicated in the table and in the drawing

### ■ Damper positioning

Position the damper in the opening so that the side of the closing mechanism extends as indicated in the table and in the drawing.

### ■ Filling

Fill the space between the wall and the damper as indicated in the table and in the drawing.

Cover the sealing by applying on both faces of the wall a layer of plasterboard, to a total minimum thickness of 20 mm per side, to make a frame with a side 150 mm greater than the nominal diameter of the damper.

Fire resistance classification	"D" hole size [mm]	Wall minimum thickness "S" [mm]	Sealing
<b>EI 90 S Installation within vertical light wall (Shaft wall)</b>			
EI 90 S (300 Pa)	From $(\varnothing + 50) \times (\varnothing + 50)$ To $(\varnothing + 70) \times (\varnothing + 70)$ (square hole)	90	Mortar or plaster putty with infill plasterboard (thickness 20 mm)

- |  |  |
|--|--|
| 1. Plasterboard thickness 20 mm              | 5. Self-drilling screw $\varnothing 3,5 \times 45$ mm                                      |
| 2. Plasterboard arch infill, thickness 20 mm | D Hole size: see table above   |
| 3. Mortar M-10, EN998-2 or plaster putty     | Lp Overlap length between fire damper and duct: see section Dimension <a href="#">p.11</a> |
| 4. Metal frame                               |  |

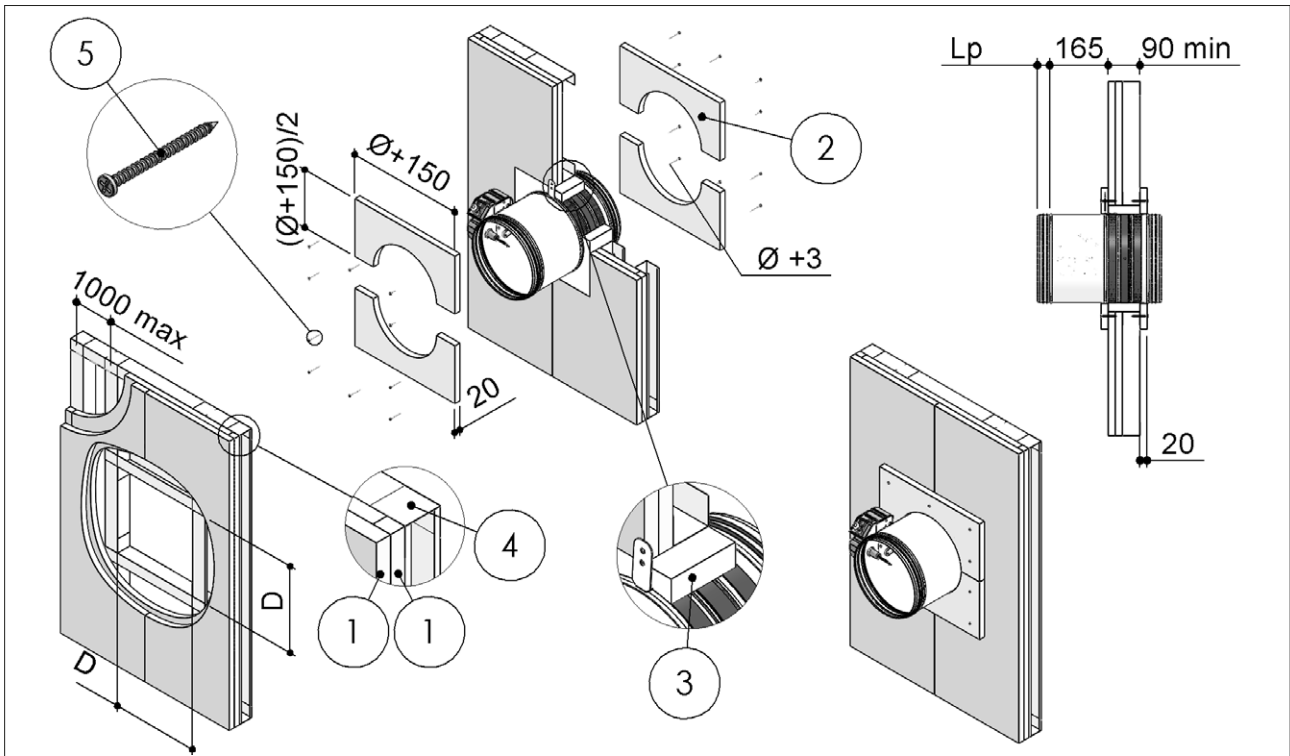

# ELECTRICAL CONNECTIONS

## Electrical wiring

Electrical connections must be done by qualified and trained people.

Switch off the power supply before starting any work on the electric elements. Never switch on the power supply during electrical connections.

### Manual and compact manual

#### S1-25 electric board (S2 optional) for blade position microswitches (manual)

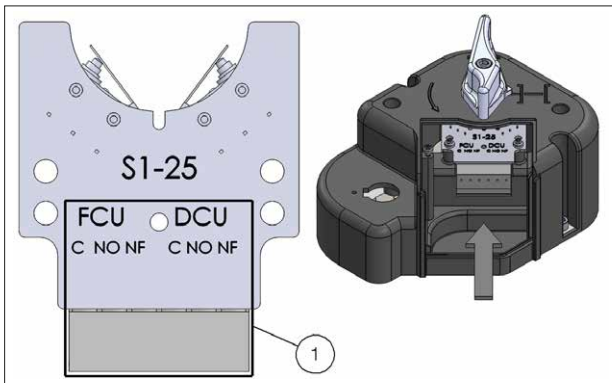

#### S1-25-B electric board (S2 optional) for blade position microswitches (compact manual)

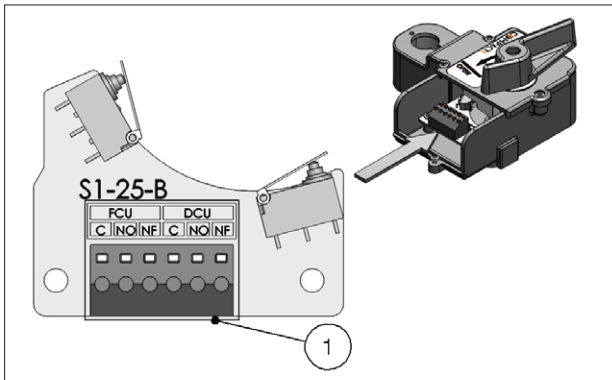

- 1 Microswitch contacts for blade position
- FCU Closed blade contact
- DCU Open blade contact
- NO Normally open
- C Common
- NF Normally closed

### Manual with magnet - MR/MI version (the magnet is powered using 24 V DC/48 V DC through S0-25 electric board)

#### S0-25 electronic board (S2 optional) for 24V DC / 48V DC power supply. Blade position microswitches included

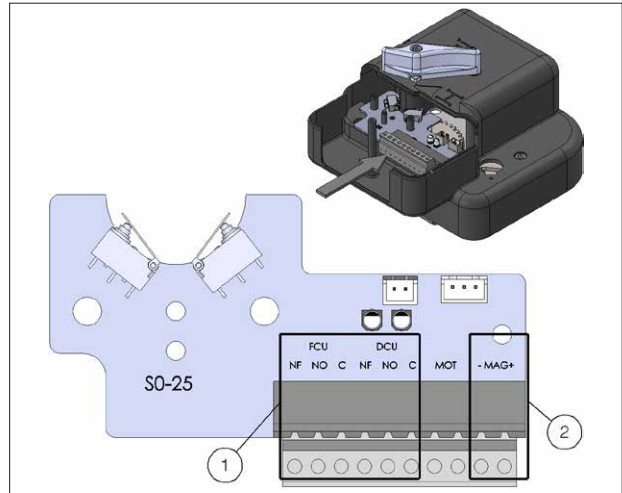

- 1 Microswitch contacts for blade position
- 2 Magnet power supply contacts. 24V DC or 48V DC. Keep to the polarity for input magnet

- MAG Magnet power supply
- FCU Closed blade contact
- DCU Open blade contact
- NO Normally open
- C Common
- NF Normally closed

### S2 microswitches position for manual control and magnetic control

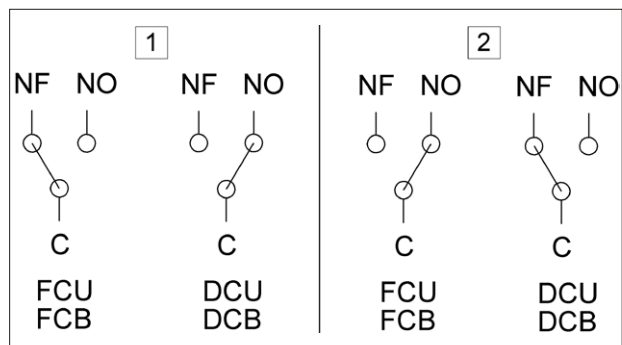

- 1. The fire damper's blade is open (the air flow is allowed)
- 2. The fire damper's blade is closed (the air flow is not allowed)
- FCU Closed blade contact
- DCU Open blade contact
- NO Normally open
- C Common
- NF Normally closed

Motorized version

**Belimo servomotor:**

BFL24T, BFN24T, BF24T, BFL230T, BFN230T, BF230T.

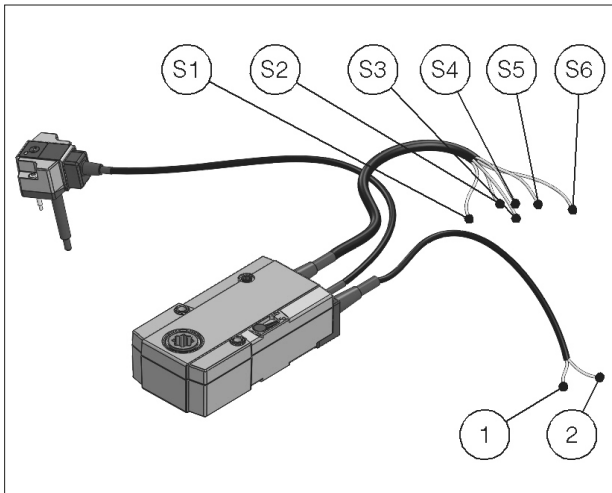

**Siemens servomotor:**

GRA126, GNA126, GGA126.

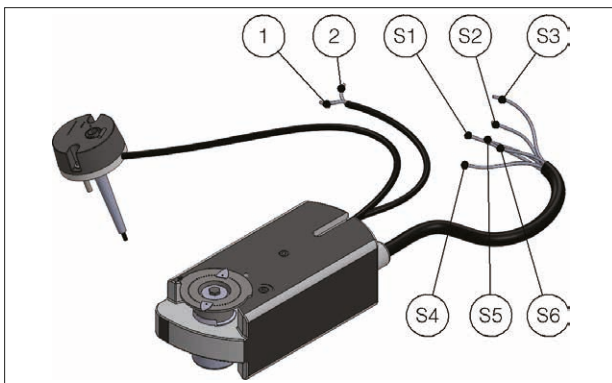

**Siemens servomotor:**

GRA326, GNA326, GGA326.

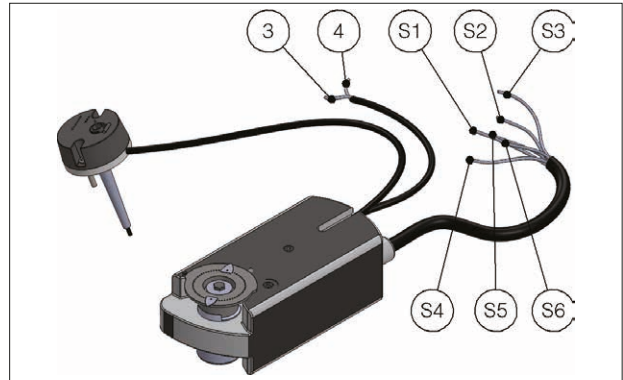

**Motorized fire dampers electrical wiring**

To connect the dampers to the power supply, proceed as follows:

- Check that the voltage and electrical frequency are equivalent to those of the motor of the servomotor (check the motor's information label);
- Make the connections as shown in the below diagram.

**Microswitches position for motorized version**

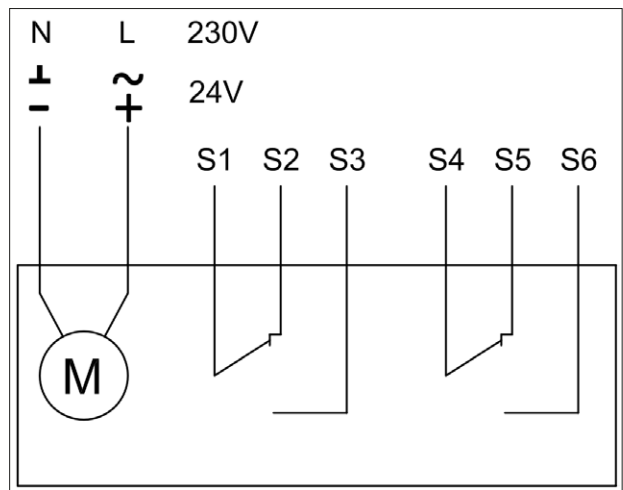

24V AC/DC power supply

-/ - Negative (DC) or neutral (AC) black wire

~/+ Positive (DC) or phase (AC) red wire

230V AC power supply

N Neutral blue wire

L Phase brown wire

Microswitches position contacts

S1 Common closed damper microswitch

S2 Normally closed, closed damper microswitch

S3 Normally opened, closed damper microswitch

S4 Common open damper microswitch

S5 Normally closed, open damper microswitch

S6 Normally opened, open damper microswitch

Electrical specifications

Manual and compact manual

Manual with magnet  
Belimo motorized version  
Siemens motorized version

Voltage and power consumption	-	Magnet (WH25MR/MI): 24/48 V DC (automatic voltage switching on 50-25 electric board for 24 V magnet)	
		Power interruption magnet (MR): P = 1,6 W	Power input magnet (MI): P = 3,4 W
		Motor 24 V AC/DC (WH25VSB): Belimo BFL24T Opening: 2,5 W In stand-by: 0,8 W	Motor 230 V AC (WH25DSB): Belimo BFL230T: Opening: 3,5 W In stand-by: 1,1 W
		Motor 24 V AC/DC (WH25VSS): Siemens GRA126 Opening: 3,5 W In stand-by: 2 W	Motor 230 V AC (WH25DSS): Siemens GRA326 Opening: 4,5 W In stand-by: 3,5 W
Microswitches position contacts	Manual control version: 12 V DC / 2 A 125 V AC / 0,1 A	Motorized version: Siemens: AC 24 V...230 V / 6 (2) A Belimo: DC 5 V...AC 250 V / 1 mA...3 A (0,5 A)	
Blade closing time	Spring: 1 s	motor: < 30 s	
Protection degree	IP42	IP42 MAGNETIC VERSION IP54 MOTORIZED VERSION	

# MAINTENANCE AND INSPECTIONS

Fire dampers and control mechanisms do not require routine maintenance.

Extraordinary maintenance (repairs) and periodic inspection operations are the responsibility of the ventilation system operator.

The implementation of a periodic inspection plan allows to guarantee the efficiency and functionality of the fire dampers for the fire safety of the building.

## ■ Periodic inspection and cleaning

Periodic inspection shall be performed in accordance with the requirements of the law or by the building regulations or other local regulations.

In the absence of specific regulations (or to their complement), in accordance with point 8.3 of the EN 1560 standard, it is recommended to carry out the following control activities at intervals of no more than 6 months:

- If the damper is connected to a remote control or command system (eg BMS or alarm or fire detection), that responds correctly to commands by performing at least one opening and closing test and verifying the correct movement of the blade and the correct functioning of the microswitches (limit switches).
- If the damper is not connected to a remote control or command system, manually execute an opening and closing test and check the correct movement of the blade and the correct functioning of the microswitches (limit switches) if present.

Together with the control activities, it is recommended to visually verify the absence of corrosion, the integrity of the electrical wiring and the sealing of the construction support.

Damper cleaning is included in the ordinary maintenance activities of the ventilation ducts.

Fire dampers can be cleaned with a dry or wet cloth.

In the case of resistant dirt, it is possible to use normal household detergents.

If prescribed for the type of building, it is possible to use disinfectant detergents.

The use of detergents or mechanical abrasive cleaning systems is not permitted.

These indications comply with the standards EN 15650 annex D and EN 15423 annex C.

## ■ Repair

For safety reasons, repair activities involving fire-fighting components must be carried out only by qualified personnel.

Only original spare parts supplied by the fire damper manufacturer must be used.

A functional test must be performed after each repair.

At the end of the inspection, cleaning or repair operations, check that the fire damper is in the normal operating position.

Keep records of all inspections, repair activities, any problems encountered and their resolution.

This practice, even when not mandatory, is very useful in practice.

## ■ Disposal

Disposal in case of destruction must be carried out in accordance with national legislation. For electrical and electronic parts also refer to EU Directive 2011/65.

## SELECTION

### ■ Air flow rates in relation to the diameter

Maximum frontal air speed = 12 m/s

∅	Front section	Net section	Maximum air flow
mm	m <sup>2</sup>	m <sup>2</sup>	m <sup>3</sup> /h
100	0,008	0,006	350
125	0,012	0,009	550
140	0,015	0,012	650
150	0,018	0,014	750
160	0,020	0,016	850
180	0,025	0,021	1100
200	0,031	0,027	1350
224	0,039	0,034	1700
250	0,049	0,043	2100
280	0,062	0,055	2650
300	0,071	0,063	3050
315	0,078	0,070	3350

### ■ Air flow rates as a function of the pressure drop

∅	ΔP 20 Pa		ΔP 30 Pa		ΔP 40 Pa	
	Q	Lw	Q	Lw	Q	Lw
mm	m <sup>3</sup> /h	dB(A)	m <sup>3</sup> /h	dB(A)	m <sup>3</sup> /h	dB(A)
100	111	27,5	137	32,7	160	36,6
125	205	29,3	254	34,7	296	38,5
140	281	30,3	348	35,7	406	39,5
150	340	30,9	422	36,3	491	40,1
160	407	31,5	505	36,9	588	40,7
180	564	32,5	700	37,9	815	41,7
200	756	33,5	937	38,8	1091	42,7
224	1035	34,5	1283	39,8	1494	43,6
250	1404	35,4	1740	40,8	2026	44,6
280	1922	36,4	2382	41,8	>Qmax	--
300	2328	37,0	2885	42,4	>Qmax	--
315	2665	37,5	3303	42,8	>Qmax	--

### ■ Air flow rates as a function of generated sound levels

∅	Lw 30 dB(A)		Lw 35 dB(A)		Lw 40 dB(A)	
	Q	ΔP	Q	ΔP	Q	ΔP
mm	m <sup>3</sup> /h	Pa	m <sup>3</sup> /h	Pa	m <sup>3</sup> /h	Pa
100	123	24,5	150	35,6	183	51,8
125	211	21,1	258	30,8	314	44,6
140	278	19,6	339	28,5	414	41,6
150	328	18,6	401	27,3	489	39,6
160	384	17,9	468	26,0	572	38,0
180	510	16,5	623	24,1	761	35,2
200	659	15,4	804	22,5	982	32,8
224	867	14,3	1058	20,8	1292	30,4
250	1131	13,3	1381	19,4	1686	28,3
280	1489	12,3	1817	18,0	2219	26,2
300	1759	11,8	2148	17,2	2623	25,1
315	1980	11,4	2418	16,6	2952	24,3



■ Pressure drop and sound level graph

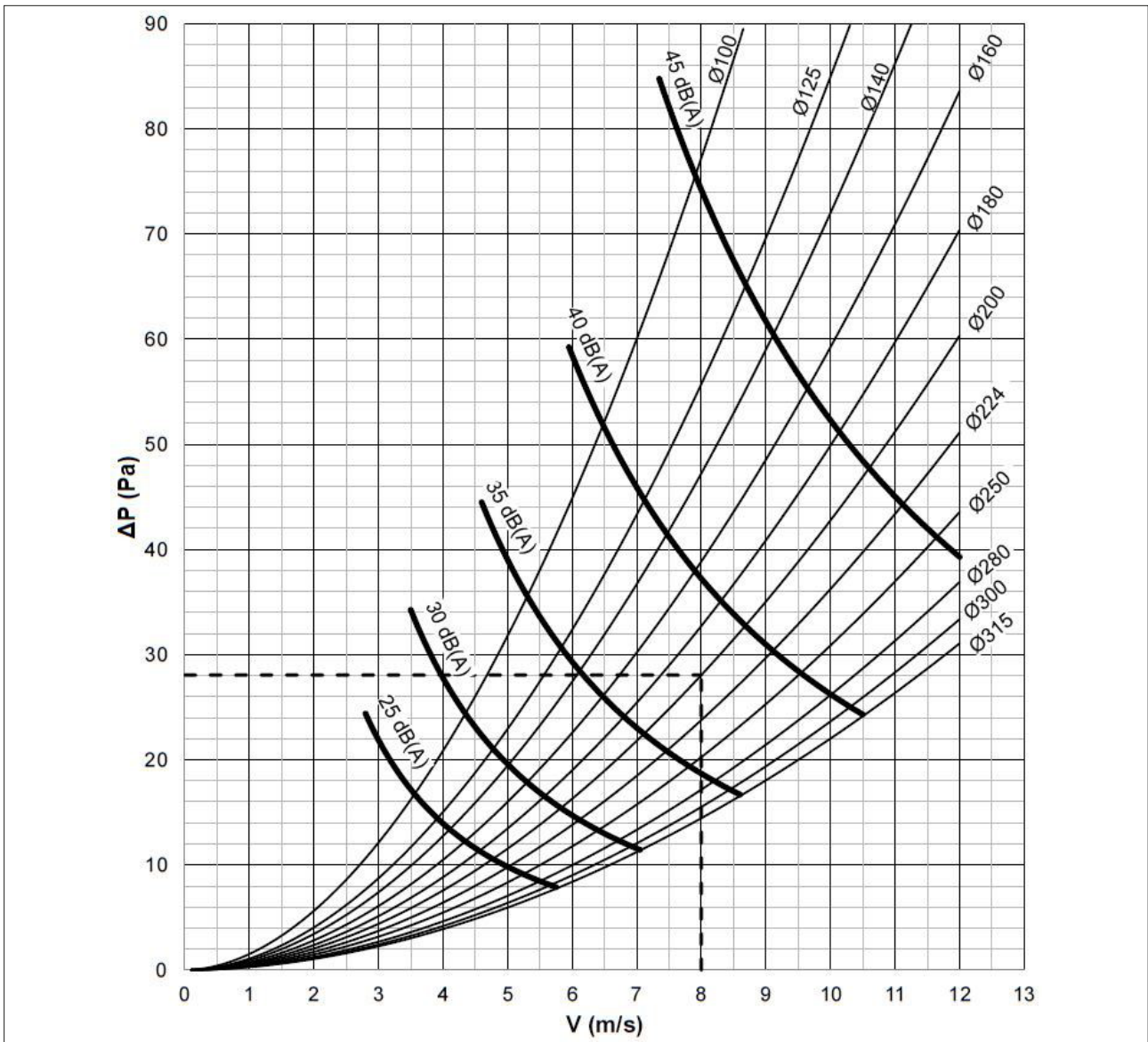

**Example**

∅ = Diameter [mm]	∅ = 200 mm
Q = Air flow [m <sup>3</sup> /h]	Q = 900 m <sup>3</sup> /h
V1 = Frontal air speed [m/s]	V1 = 8 m/s
ΔP = Pressure drop [Pa]	From graph: ΔP = 28 Pa
Lw = Sound level [dB(A)]	From graph: Lw = 38 dB(A)

■ Sound spectrum table

Correction used to estimate the octave band spectrum (Values to be added to the noise levels in dB(A))								
Frontal speed	Frequency Hz							
m/s	63	125	250	500	1000	2000	4000	8000
6	15	7	4	-4	-9	-10	-15	-22
9	17	8	5	-4	-9	-10	-19	-20
12	20	9	5	-4	-9	-15	-16	-12



# ACCESSORIES AND SPARE PARTS

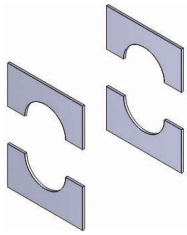

Kit 4 x plasterboard shaped sealing panels for WH25 from ø100 to ø315 (thickness 12.5 mm): not used for TAMP-WH25-Ø installation within vertical light wall (Shaft wall)  
**Not used for WHS25 fire damper**

Kit microswitch S1-25-B board + 2 fixing screws, 25/23 series (compact manual)

WHKS125C

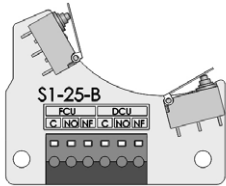

Kit microswitch S1-25 board + 2 fixing screws, 25/23 series

WHKS125



Kit microswitch S0-25 board + 2 fixing screws for manual magnetic control 25/23 series and magnet power supply 24 V DC or 48 V DC

WHKS025

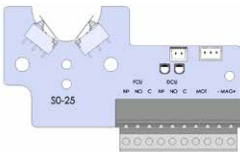

Kit power supply input magnet only + 2 screws for manual magnetic mechanism, 25/23 series

WHKMAG125

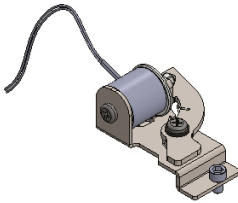

Kit power supply interruption magnet only + 2 screws for manual magnetic mechanism 25/23 series

WHKMAGR25

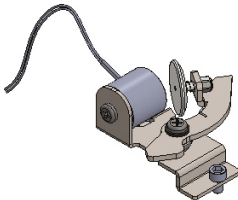

Red fuseholder group 25 series with fuse WK70  
Red fuseholder group 25 series with fuse WK70 (compact manual)  
Blue fuseholder group 25 series with fuse WK70  
Blue fuseholder group 25 series with fuse WK70 (compact manual)  
Red fuseholder group 25 series without fuse  
Red fuseholder group 25 series without fuse (compact manual)  
Blue fuseholder group 25 series without fuse  
Blue fuseholder group 25 series without fuse (compact manual)

WHKDISR  
WHKDISCR  
WHKDISB  
WHKDISCB  
3WHKDISR  
FMWHK044  
3WHKDISB  
FMWHK028

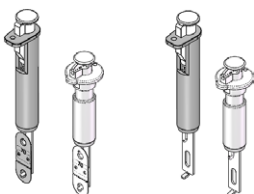

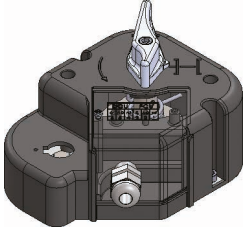
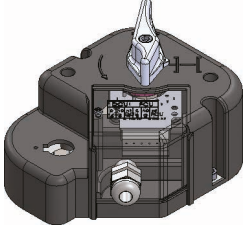
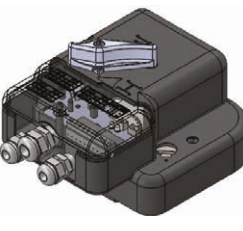
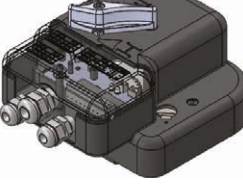
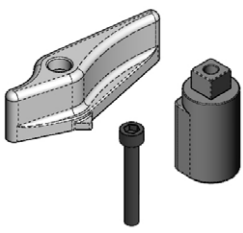
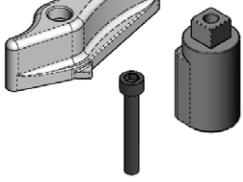
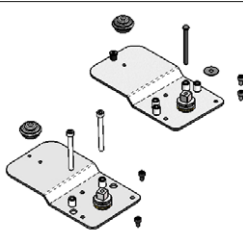
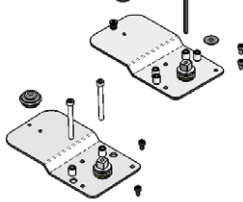
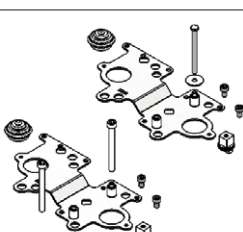
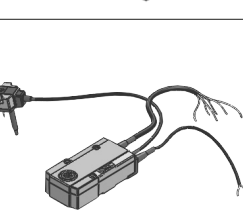
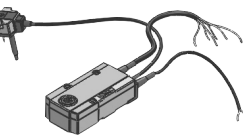
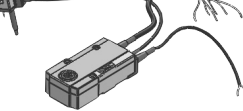
	<p>Kit mechanism manual 25 series + carter + cam and lever + 2 fixing screws (without fuseholder group) WHK25MANB</p>
	<p>Kit mechanism manual 25 series + carter + cam and lever + elect. board S1-25 + 2 fixing screws (without fuseholder group) WHK25MANBS2</p>
	<p>Manual mechanism for 25 series + elect. board S0-25 + interr. magnet 24 V DC or 48 V DC+ carter and screws (without fuseholder group) WHK25MANMMR</p>
	<p>Manual mechanism for 25 series + elect. board S0-25 + input magnet 24 V DC or 48 V DC+ carter and screws (without fuseholder group) WHK25MANMMI</p>
	<p>Red reset lever for WH/WK25 (spare part for manual mechanism) WHK25PLSLEVA</p>
	<p>Blue reset lever for WH/WK25 (spare part for manual mechanism) WHK23PLSLEVA</p>
	<p>Motorized plate WH25/23 for Siemens GRA + fixing screws (motor not included) WH25MTS</p>
	<p>Motorized plate WH25/23 for Belimo BFL + fixing screws (motor not included) WH25SMB</p>
	<p>Motorized plate WH25/23 (compact) for Siemens GRA + fixing screws (motor not included) WH25CMTS</p>
	<p>Motorized plate WH25/23 (compact) for Belimo BFL + fixing screws (motor not included) WH25CSMB</p>
	<p>Belimo motor for dampers predisposed for use with BFL24T, 24 V AC/DC power supply, thermofuse 72 °C BFL24T</p>
	<p>Belimo motor for dampers predisposed for use with BFL24T-ST, 24 V AC/DC power supply, thermofuse 72 °C with connection plugs for control and monitoring systems BFL24T-ST</p>
	<p>Belimo motor for dampers predisposed for use with BFL230T, 230 V AC power supply, thermofuse 72 °C BFL230T</p>

	<p>Siemens motor for dampers predisposed for use with GRA126, 24 V AC/DC power supply thermofuse 72 °C GRA126 Siemens motor for dampers predisposed for use with GRA326, 230 V AC power supply, thermofuse 72 °C GRA326</p>	
	<p>Copper mechanical thermofuse 70 °C for manual mechanism WK70 Copper mechanical thermofuse 95 °C for manual mechanism WK95 Thermofuse 72 °C for Belimo motor BFL and BFN (spare part) WWEZBAT72 Thermofuse 95 °C for Belimo motor BFL and BFN (accessory) WWEZBAT95 Thermofuse 72 °C for Siemens motors GRA, GNA and GGA (spare part) MT-FUSASK79.4 Thermofuse 95 °C for Siemens motors GRA, GNA and GGA (accessory) MT-FUSASK79.5</p>	
	<p>Matt black epoxy powder painting for WH25 fire damper casing Attention: Lindab Safe connectors can't be painted.</p> <ul style="list-style-type: none"> <li>• Corrosion resistance: Excellent</li> <li>• Heat resistance: Very good</li> <li>• Resistance direct impact: ≥2Kg 5cm ISO 6272</li> <li>• Resistance reverse impact: ≥2Kg 5cm ISO 6272</li> <li>• Resistance umidity chamber: after 500 hrs noy blistering ISO 6270</li> <li>• Resistance salt spray test: after 500 hrs creeping at cross-cut &lt;1mm ISO 9227</li> </ul>	<p>WH25PAINT[Ø]</p>
	<p>Communication and control unit BKS24-1B to control and monitor 1 fire damper with Belimo motor</p>	<p>WHBKS241B</p>
	<p>Communication and control unit BKS24-9A to control and monitor up to 9 fire dampers with Belimo motor</p>	<p>WHBKS249A</p>
	<p>Communication and power supply unit: BKN230-24 for Belimo motors BFL24T-ST, BFN24T-ST e BF24T-ST WHKBKN23024 Modbus Communication and power supply unit: BKN230-24MOD for Belimo motors BFL24T-ST, BFN24T-ST and BF24T-ST WHKBKN230-24MOD Communication and power supply unit MPBUS for BKS24-9A or gateways Belimo UK24MOD and UK24BAC: BKN230-24-C-MP for Belimo motors BFL24T-ST, BFN24T-ST and BF24T-ST WHKBKN230-24-C-MP Modbus Communication and power supply unit: BKN230MOD for Belimo motors BFL230T, BFN230T and BF230T WHKBKN230MOD</p>	
	<p>Gateway UK24BAC Belimo for BACnet communication</p>	<p>WHKUK24BAC</p>

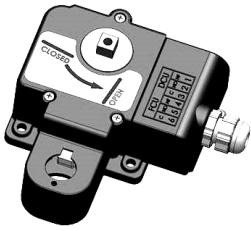

Spare part blue manual compact mechanism (without fuseholder group, reset lever and fixing screws)	FMWHK042V00
Spare part grey manual compact mechanism (without fuseholder group, reset lever and fixing screws)	FMWHK042V01
Spare part red manual compact mechanism (without fuseholder group, reset lever and fixing screws)	FMWHK042V02



Reset lever for WH/WK25 (spare part for manual compact mechanism) blue	PL-PS-WHK25CLEVA
Reset lever for WH/WK25 (spare part for manual compact mechanism) red	PL-PS-WHK25CLEVAR

(1) Is recommended to install the position microswitches for the manual fire dampers with magnet.

## HOW TO ORDER

### Motorized fire dampers

Code		
<b>Type</b>	WH	Circular fire damper
<b>Series</b>	25	Blade thickness 25 mm - 500 Pa air sealing
<b>Connection</b>	U	Connection with Lindab Safe
<b>Motor type</b>	VSS	Siemens motor GRA126 (24V)
	DSS	Siemens motor GRA326 (230V)
	VSB	Belimo motor BFL24T (24V)
	DSB	Belimo motor BFL230T (230V)
	TSB	Belimo motor BFL24T-ST (24V) with connection plugs for integration in control and monitoring systems
<b>Dimension</b>	XYZ	Nominal diameter (mm)

### Fire damper with manual control

Code		
<b>Type</b>	WH	Circular fire damper
<b>Series</b>	25	Blade thickness 25 mm - 500 Pa air sealing
<b>Connection</b>	U	Connection with Lindab Safe
<b>Command type</b>	B	Manual command
	C	Compact manual command
	M	Manual command with magnet
<b>Position indication microswitches</b>	S0	Without position microswitch
	S2	With two position microswitches (always for MR/MI versions)
	M0	Without magnet (only for command type "B")
<b>Magnet</b>	LR	With power supply interruption magnet, 24 V DC only
	LI	With power supply input magnet, 24 V DC only
	MR	With power supply interruption magnet through electric board 24 V DC or 48 V DC and with two position microswitches
	MI	With power supply input magnet through electric board 24 V DC or 48 V DC and with two position microswitches
	<b>Dimension</b>	XYZ

Examples	Code
WH25 fire damper with manual control, Ø 200	WH25UB-S0-M0-200
WH25 fire damper with manual control and microswitches, Ø 160	WH25UB-S2-M0-160
WH25 fire damper with manual control, power input magnet through electric board (24 V DC or 48 V DC), Ø 100	WH25UM-S2-MI-100
WH25 Siemens motorized 230V fire damper, Ø 250	WH25UDSS-250

### Electric motor driven actuators

Motor type	Diameters											
	100	125	140	150	160	180	200	224	250	280	300	315
<b>Belimo</b>	S	S	S	S	S	S	S	S	S	S	S	S
<b>Siemens</b>	S	S	S	S	S	S	S	S	S	S	S	S

	Belimo				Siemens			
	24 V		230V		24 V		230V	
<b>S</b>	BFL24T		BFL230T		GRA126		GRA326	

# SPECIFICATION TEXT

## ■ Series WH25 compact circular fire dampers

### Description

WH25 circular fire damper tested for fire resistance and smoke seal with 500 Pa depression as per EN 1366-2, classified according to EN 13501-3 and CE marked according to European Regulation UE 305/2011 and EN 15650 standard. Allows maximum safety for fire protection inside buildings providing perfect heat insulation and cold and hot smokes tightness. Can be connected to fire protection alarm system or smokes detection to anticipate blade closure before fire, prevents indirect damages caused by smokes generated by combustion.

### Technical characteristics

- Available diameters from 100 to 315 mm
- Air duct connection gasket.
- Lindab Safe: The system is based on a double, factory-installed seal made of EPDM rubber. This seal makes the system quick and easy to mount. Refer to Lindab web site for further information.
- Closing mechanism built according to UNI 10365, with thermal fuse certified to ISO 10294-4, a test button to check the correct working of the damper, a release system to block the damper in closed position and a visual signal "open/closed". The closing mechanism can be easily interchanged and substituted:
  - with mechanical release and manual rearming
  - with mechanical release and manual rearming, can be released remotely via a magnet and electric and signal
  - with electric release and rearming, via and integrated Siemens or Belimo system tested according to EN 15650, composed by an electric thermal fuse and remote controlled servomotor via an electrical signal
- Blade damper made from calcium silicate insulating material, rotating on steel gudgeon pins, complete with silicon lip gasket for the air seal of cold smoke, as per EN 1366-2
- Thermal, expanding graphite gasket
- Thermal fuse with melting point certified ISO 10294-4 at 70 °C or 95 °C (version with mechanical release) or at 72 °C (version with servo motor)
- Absence of thermal bridge between the wall of installation and the ducts before and after
- Resistance to salt spray, tested with severity 2, according to EN 60068-2-52
- Casing leakage Class C according to EN 1751

### Installation

- Installation within vertical rigid walls made from aerated concrete blocks, standard concrete or masonry with a minimum thickness of 100 mm and minimum density of 550 kg/m<sup>3</sup> (EI 120 S)  
Mortar or plaster putty sealing  
Plasterboard and rock wool 100 kg/m<sup>3</sup> sealing (EI 90 S)
- Installation within light plasterboard walls with minimum thickness of 100 mm and sealed with rock wool minimum density 80 kg/m<sup>3</sup> (EI 60 S) or rock wool minimum density 100 kg/m<sup>3</sup> (EI 90 S) or mortar or plaster putty (EI 120 S)

- Installation within light walls made with gypsum blocks 100 mm thick and minimum density 995 kg/m<sup>3</sup> (EI 120 S) or minimum thickness of 70 mm and minimum density 995 kg/m<sup>3</sup> (EI 90 S)
- Installation within concrete floors with a minimum thickness of 150 mm and minimum density of 650 kg/m<sup>3</sup> (EI 120 S) or aerated concrete with minimum thickness 100 mm (EI 90 S) and minimum density 650 kg/m<sup>3</sup>
- Installation with Fire Batt (Weichschott) sealing within vertical rigid walls made from aerated concrete blocks, standard concrete or masonry with minimum thickness 100 mm and minimum density 550 kg/m<sup>3</sup>, within light plasterboard walls with minimum thickness of 100 mm, within gypsum blocks light walls with with minimum thickness 100 mm and minimum density 995 kg/m<sup>3</sup> (EI 120 S)
- Installation with Fire Batt (Weichschott) sealing within concrete floors or aerated concrete with minimum thickness 150 mm and minimum density 650 kg/m<sup>3</sup> (EI 90 S)
- Remote installation within vertical rigid walls made from aerated concrete blocks, standard concrete or masonry with minimum thickness 100 mm and minimum density 550 kg/m<sup>3</sup>, within light plasterboard walls with minimum thickness of 100 mm, within gypsum blocks light walls with with minimum thickness 100 mm and minimum density 995 kg/m<sup>3</sup> (EI 120 S for 300 Pa and EI 90 S for 500 Pa depression).
- Remote installation with Fire Batt (Weichschott) sealing within vertical rigid walls made from aerated concrete blocks, standard concrete or masonry with minimum thickness 100 mm and minimum density 550 kg/m<sup>3</sup>, within light plasterboard walls with minimum thickness of 100 mm, within gypsum blocks light walls with with minimum thickness 100 mm and minimum density 995 kg/m<sup>3</sup> (EI 120 S for 300 Pa depression and EI 90 S for 500 Pa depression)
- Remote installation within concrete floors with a minimum thickness of 150 mm and minimum density of 650 kg/m<sup>3</sup> (EI 120 S for 300 Pa) or aerated concrete with minimum thickness 100 mm (EI 90 S for 500 Pa) and minimum density 650 kg/m<sup>3</sup>
- EI 90 S Installation within vertical light wall (Shaft wall)
- Fire resistance characteristics independent from direction of the source of the fire according to EN 1366-2 article 6.2
- Installation possible with damper blade placed horizontally or vertically, with the mechanism placed in left/right or above/below

### Accessories

- Motorised version with 24 V or 230 V servomotor installed on the damper
- Set of microswitches with three NO/NC position detecting connectors for open and closed damper, as per standard UNI 10365
- Immission and Interruption magnet 24/48 V DC

- Power supply and communication unit MP-Bus, Modbus, Bacnet



## REVISION INDEX

Revision n°	Date of issue	Description
16/04	2016/04	<p>First issue</p> <p>Added section:</p> <ul style="list-style-type: none"> <li>• Positioning brackets before fixing <a href="#">p. 12</a></li> <li>• Indications for the correct duct suspension and for damper connection</li> <li>• Installation remote from the vertical rigid wall and the vertical light wall (gypsum blocks wall) <a href="#">p. 26</a></li> <li>• Installation remote from the vertical light wall (plasterboard) <a href="#">p. 28</a></li> <li>• Installations remote from the vertical wall with Fire Batt (Weichschott) sealing <a href="#">p. 30</a></li> </ul>
16/10	2016/10	<p>Updated section:</p> <ul style="list-style-type: none"> <li>• Fire resistance classification according to EN 13501-3-2009 <a href="#">p. 5</a></li> <li>• Minimum distances <a href="#">p. 15</a></li> <li>• How to order <a href="#">p. 45</a></li> <li>• Mechanism type <a href="#">p. 8</a></li> <li>• Electrical connections <a href="#">p. 35</a></li> <li>• Specification Text <a href="#">p. 46</a></li> </ul> <p>Updated table:</p> <ul style="list-style-type: none"> <li>• Accessories and spare parts <a href="#">p. 41</a></li> </ul> <p>General improvements</p>
17/04	2017/04	<p>Added section:</p> <ul style="list-style-type: none"> <li>• Installations remote from the floor <a href="#">p. 32</a></li> <li>• Installation within vertical light wall (Shaft wall) <a href="#">p. 34</a></li> </ul> <p>Updated section:</p> <ul style="list-style-type: none"> <li>• Indications for the correct duct suspension and for damper connection</li> <li>• Installations within vertical light wall (plasterboard) <a href="#">p. 21</a></li> <li>• Installations within vertical wall with Fire Batt (Weichschott) sealing <a href="#">p. 24</a></li> <li>• Installation within floor with Fire Batt (Weichschott) sealing <a href="#">p. 25</a></li> <li>• Installations remote from the vertical wall with Fire Batt (Weichschott) sealing <a href="#">p. 30</a></li> <li>• Installation remote from the vertical rigid wall and the vertical light wall (gypsum blocks wall) <a href="#">p. 26</a></li> <li>• Installation remote from the vertical light wall (plasterboard) <a href="#">p. 28</a></li> <li>• Maintenance and inspections <a href="#">p. 38</a></li> </ul> <p>Updated table:</p> <ul style="list-style-type: none"> <li>• Accessories and spare parts <a href="#">p. 41</a></li> <li>• Fire resistance classification according to EN 13501-3-2009 <a href="#">p. 5</a></li> <li>• Minimum distances <a href="#">p. 15</a></li> </ul> <p>General improvements</p>
19/05	2019/05	<p>Added section:</p> <ul style="list-style-type: none"> <li>• Installation of flexible connectors in order to balance out the ventilation ducts expansion <a href="#">p. 12</a></li> </ul> <p>Updated section:</p> <ul style="list-style-type: none"> <li>• Installation <a href="#">p. 12</a></li> <li>• Not allowed uses <a href="#">p. 12</a></li> <li>• Minimum distances <a href="#">p. 15</a></li> <li>• Light plasterboard vertical walls <a href="#">p. 17</a></li> <li>• Maintenance and inspections <a href="#">p. 38</a></li> <li>• Accessories and spare parts <a href="#">p. 41</a></li> </ul> <p>General improvements</p>

As the manufacturer is constantly improving its products, the aesthetic or dimensional features, the technical data, the equipment and accessories indicated could be subject to variations.



Lindab | We simplify construction

[www.lindab.com](http://www.lindab.com) - Fire dampers are manufactured by MP3 Srl [www.mp3-italia.it](http://www.mp3-italia.it)



\*1MTLWH25UEN-LIND\* rev 19-05