

# Centrifugal fan

# CRCF



## Description

Centrifugal Corrosion resistant fans are made from single block strong high density UV treated and recyclable polypropylene (PPH) with no welded joint. Reversible and rotatable to any the 8 standard discharge positions by 45° increments. All fan mounting hardware in stainless steel.

Forward curved centrifugal type impeller made, of injection molded PPH. Fan wheel supplied with hub cap constructed of PPH. Wheels electronically and dynamically balanced to ISO 1940.

Direct drive, asynchronous, single or three phase, IP55. Single speed: three phase 230/400 V-50/60Hz, single phase 230V-50Hz.

Motor is outside the airstream. Three phase motors speed adjustable by variable frequency inverter drive.

## Ordering example

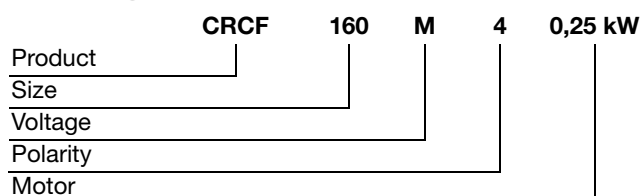

- 1
- 2
- 3
- 4
- 5
- 6
- 7**
- 8
- 9
- 10
- 11
- 12
- 13
- 14
- 15
- 16
- 17
- 18

# Centrifugal fan

# CRCF

## Dimensions

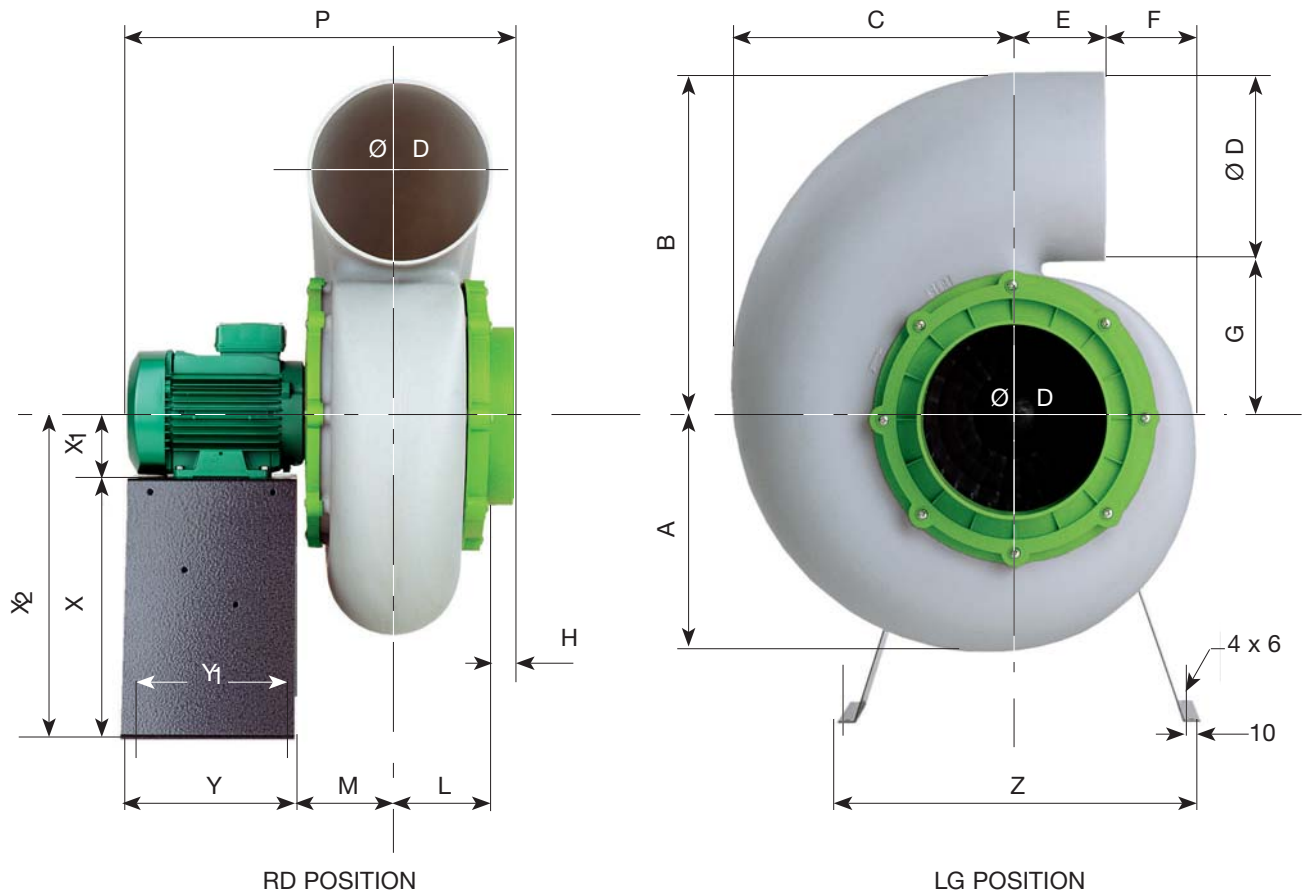

Product	A	B	C	ØD	E	F	G	H	L	M	P	Y	Y <sub>1</sub>	Z	X	X <sub>1</sub>	X <sub>2</sub>
CRCF125	170	240	203	125	100	32	115	30	70	80	360	180	160	340	240	71	311
CRCF160	208	303	240	160	100	57	143	32	84	94	390	180	160	340	240	71	311
CRCF200 (930&1450 rpm)	248	365	310	200	103	92	165	35	95	105	430	180	160	420	300	71	371
CRCF200 (2870 rpm)	248	365	310	200	103	92	165	35	95	105	515	180	160	420	300	90	390
CRCF250 (930 rpm)	300	450	373	250	117	112	198	35	110	120	510	240	220	460	370	80	450
CRCF250 (1450 rpm)	300	450	373	250	117	112	198	35	110	120	540	240	220	460	370	90	460
CRCF315 (930 rpm)	370	570	450	315	130	170	255	60	150	170	724	350	314	600	468	112	580
CRCF315 (1450 rpm)	370	570	450	315	130	170	255	60	150	170	792	350	314	600	468	112	580
CRCF500	500	600	765	550	1315	740	660	610									

M = 230 volt  
T = 400 volt

# Centrifugal fan

# CRCF

## Technical data

CRCF 125

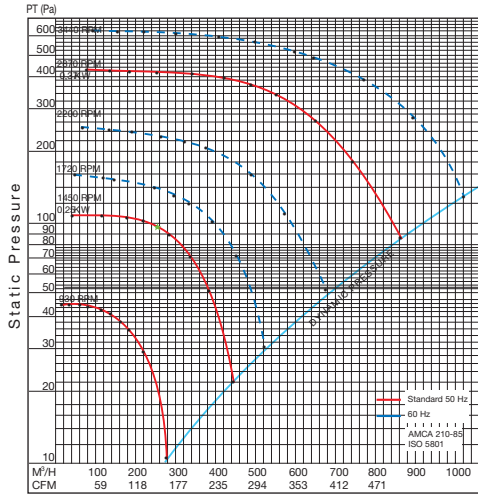

CRCF 160

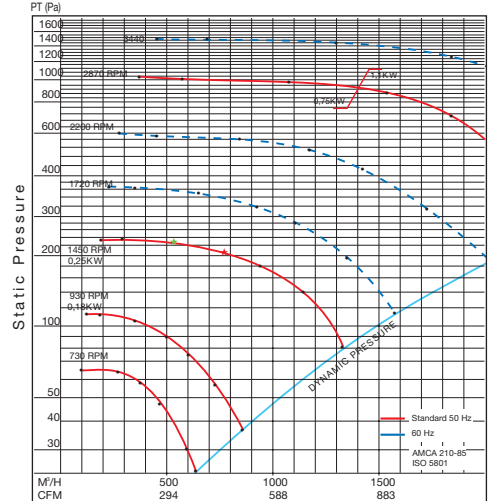

CRCF 200

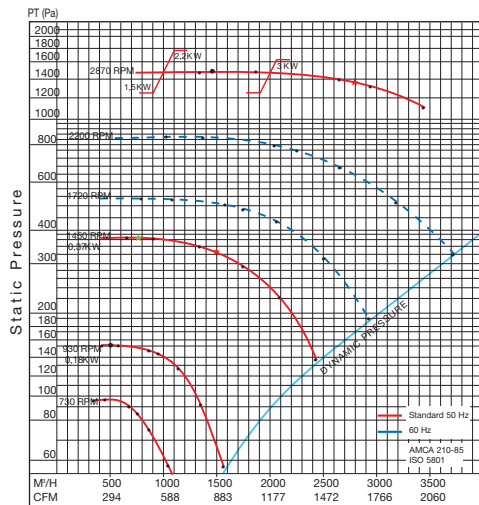

CRCF 250

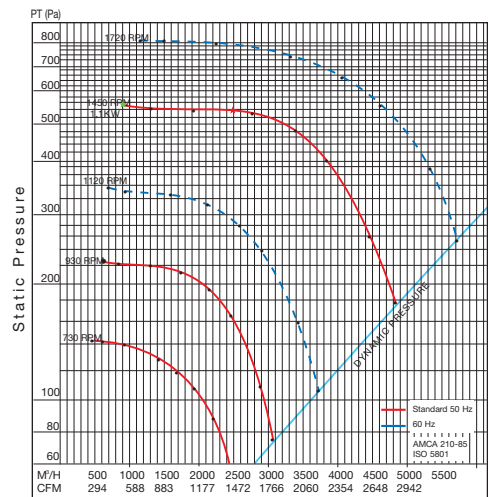

CRCF 315

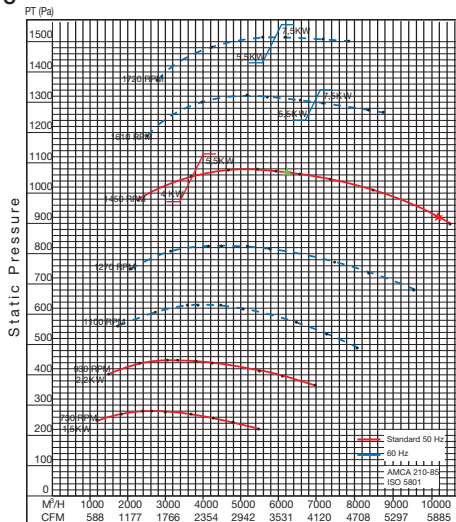

CRCF 500

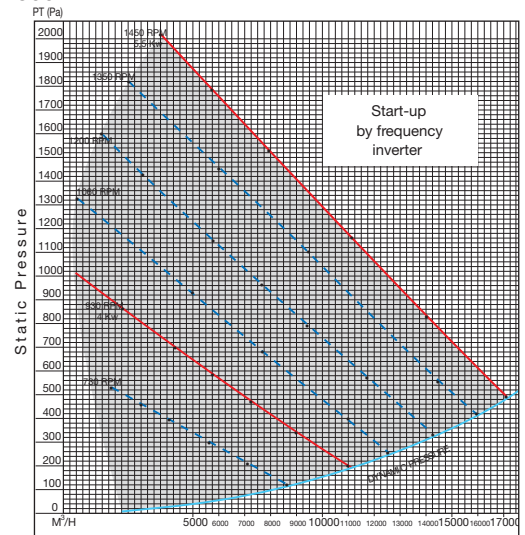

# Centrifugal fan

# CRCF

## Technical data

Product	Voltage V	Speed RPM	Motor kW	Amps FLC	m kg
CRCF125 M4 0.25kW	230	1500	0,25	2,5	8,3
CRCF125 M2 0.37kW	230	3000	0,37	3,1	8,1
CRCF160 M4 0.25kW	230	1500	0,25	2,5	9,0
CRCF160 M2 0.75kW	230	3000	0,75	5,4	10,5
CRCF200 M4 0.37kW	230	1500	0,37	3,1	11,9
CRCF250 M4 1.1kW	230	1500	1,1	9,7	13,9
CRCF125 T6 0.18kW	230/400	1000	0,18	1.5/0.85	8,3
CRCF125 T4 0.25kW	230/400	1500	0,25	1.3/0.75	7,7
CRCF125 T2 0.37kW	230/400	3000	0,37	1.7/1.00	8,0
CRCF160 T6 0.18kW	230/400	1000	0,18	1.5/0.85	9,7
CRCF160 T4 0.25kW	230/400	1500	0,25	1.3/0.75	9,0
CRCF160 T2 0.75kW	230/400	3000	0,75	3.2/1.9 1	1,4
CRCF160 T2 1.1kW	230/400	3000	1,1	4.7/2.7 1	5,9
CRCF200 T6 0.18kW	230/400	1000	0,18	1.5/0.85	11,4
CRCF200 T4 0.37kW	230/400	1500	0,37	2.1/1.2	11,5
CRCF200 T4 0.55kW	230/400	1500	0,55	3/1.8	12,3
CRCF200 T2 1.5kW	230/400	3000	1,5	5.9/3.4	22,1
CRCF200 T2 2.2kW	230/400	3000	2,2	8.8/5.1	23,9
CRCF200 T2 3kW	230/400	3000	3	10/3.6	36,0
CRCF250 T6 0.55kW	230/400	1000	0,55	3/1.8	19,6
CRCF250 T4 1.1kW	230/400	1500	1,1	4.7/2.7	23,7
CRCF315 T6 2.2kW	230/400	1000	2,2	9.6/5.5	43,2
CRCF315 T4 5.5kW	230/400	1500	5,5	20.8/11.9	53,0
CRCF315 T4 4kW	230/400	1500	4	14.8/8.5	43,6
CRCF500 T4 4kW	690/400	1200	4	9.5/5.5	215,0

Product	Sound Power Level (Breakout)					
	125	250	500	1K	2K	4K
CRCF125	55,3	51,7	52,1	49,8	41,8	36,9
CRCF160	65,1	64,9	63,8	61	52,3	50,6
CRCF200	70,1	70,8	70,1	69,8	59,8	54,7
CRCF250	75,1	76,5	76,9	73,2	68,5	63,9
CRCF315	74,5	68,2	68,4	67,4	61,2	61,3
CRCF500	73,6	73,7	69	68,6	60,6	60,1