

Bend

BTR 45°



Description

Pressed and seam welded bend.

Dimensions

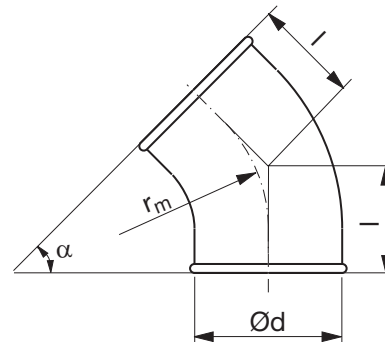

$$r_m \approx 1 \cdot d$$

Ød nom	t mm	r _m mm	l mm	m kg
80	0,5	100	71	0,20
100	0,5	100	71	0,30
125	0,5	125	82	0,30
140	0,7	135	86	0,40
150	0,7	150	92	0,43
160	0,6	160	96	0,43
180	0,7	180	110	0,68
200 **	0,6	200	135	0,80
224 **	0,7	225	145	0,86
250 **	0,7	250	156	0,86

** 2 swaged-on ends

Ordering example

