

Bend – long

BSU 45°

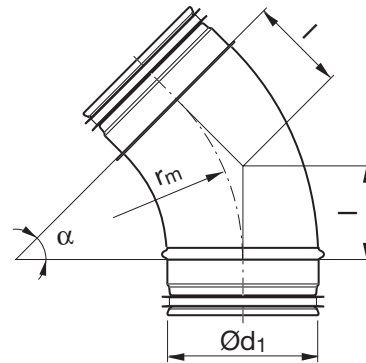

Dimensions



$$r_m \approx 1,5 \cdot d_1$$

Description

Pressed and seam welded bend.

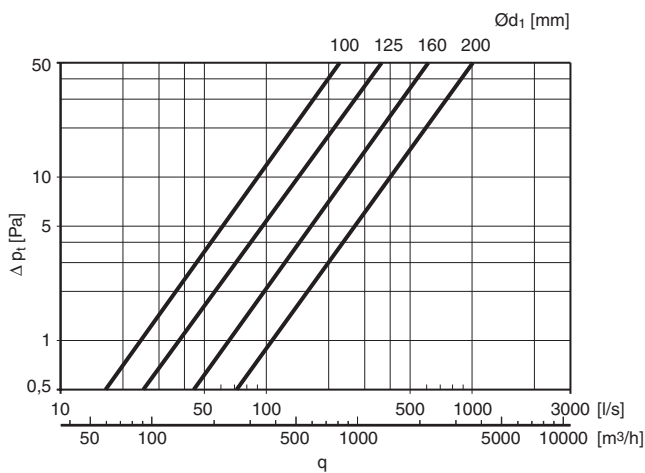

Ød ₁ nom	l [mm]	m [kg]
100	62	0,26
125	79	0,41
150	93	0,49
160	100	0,59
180	112	0,77
200	124	0,82

Ordering example

