

Bend

BSTR 45°



Description

Pressed and seam welded bend.

Dimensions

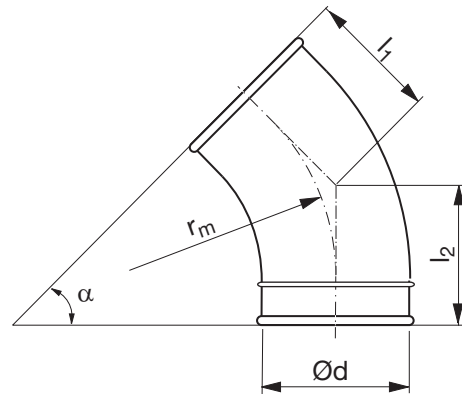

$$r_m \approx 1,5 \cdot d$$

Ød nom	t [mm]	r _m [mm]	l ₁ [mm]	l ₂ [mm]	m [kg]
100 *	0,6	150	92	118	0,30
125 *	0,7	190	109	135	0,40
150 *	0,7	225	123	149	0,50
160 *	0,7	240	129	155	0,60
180 *	0,7	270	137	164	0,90
200 **	0,6	300	176	176	0,88

* 1 swaged-on end

** 2 swaged-on ends

Ordering example

