

# Bøjning med nippel- og muffemål

# BMU45



## Beskrivelse

Presset og trådsvejt bøjning med nippelmål i den ene og muffemål i den anden ende.

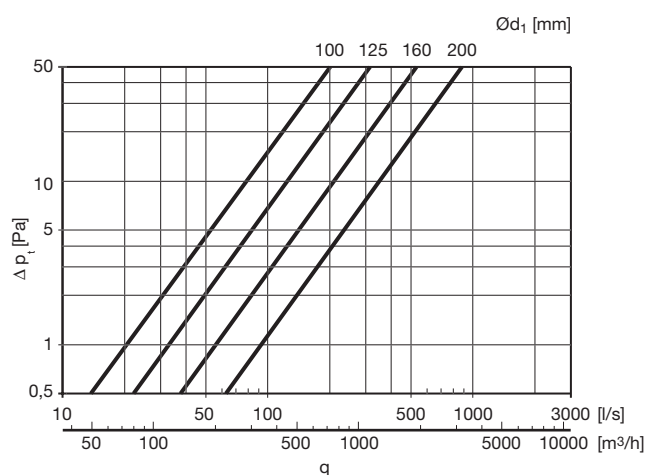

## Dimensioner

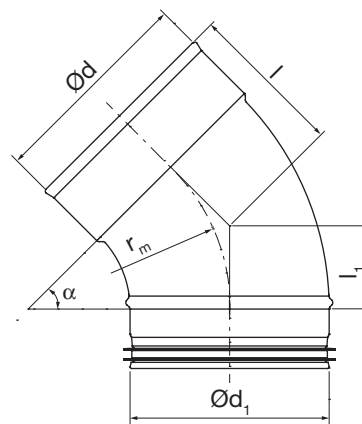

Ød₁ nom	Ød nom	l mm	l₁ mm	m kg
100	100	85	35	0,20
125	125	93	44	0,28
160	160	110	58	0,45
200	200	125	77	0,80

## Bestillingskode

Produkt	BMU	100	45
Dimension Ød₁			
Vinkel α			

