

# Bend

# BSTR 90°



## Description

Pressed and seam welded bend.

## Dimensions

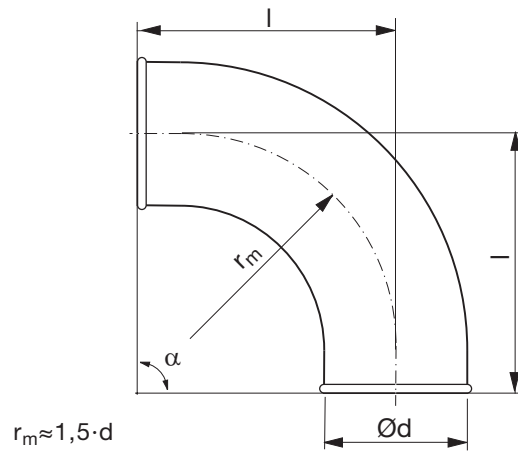

Ød nom	t mm	r <sub>m</sub> mm	l mm	m kg
100	0,6	150	180	0,50
125	0,7	190	220	0,80
150	0,7	225	255	1,10
160	0,7	240	270	1,20
180	0,7	270	295	1,60
200 **	0,6	300	352	1,63

\*\* 2 swaged-on ends

## Ordering example

