

Lindab **Plexus**

Active chilled beam



Active chilled beam

Plexus

Use

Lindab's unit Plexus gives many placement possibilities since it fits into the false ceiling 600 x 600 alternative 1200 x 600.

Plexus is provided with Angled Nozzles which are controlling the primary air into non-parallel jets in a 360 degree air pattern. The 360 degree air pattern results in shorter air throws (30%) and a draft free indoor climate. Plexus can be used for both cooling, heating and ventilation. Plexus can be equipped with the functions, Regula Secura condensation guard, down fold battery for better accessibility and pre-mounted valves and actuators. The possibilities are many and the flexibility large.

Installation

Plexus is provided in both an integrated and a free hanging model. Plexus I are mounted integrated into false ceiling there the unit is placed above the standard T-bars. Plexus X is mounted integrated into false ceilings there the unit is placed into hidden bars, for example edge DS. Plexus Y and Z are for mounting into false ceiling system edge E. Plexus F is mounted free hanging or close to the ceiling. Plexus can be delivered with horizontal or vertical air connection and with horizontal water connection.

Worth noting

By the many adaptations to ceiling tiles the Plexus beam easily can be mounted into modern buildings.

Because of Plexus 360 degree air pattern and the resulting shorter air throws many Plexus beams can be mounted into same room without creating any draft problems.

The air volume can easily be adjusted with Lindab's JetCone system, which creates a great flexibility.

Plexus is provided with a high quality design outlet frame made from powder coated strang-aluminium. The version ISA offers a precoated steel casing with integrated outlet frame.

The water battery can be turned easily on site to change e.g. connection (A5) to (A6) or vice versa (only available for 2-pipe connections and models without plus features).

The beam can be easily integrated/used in a Pascal water system to enable VAV/DCV.

Lindab's active chilled beams are Eurovent-certified and tested according to EN-15116.



Key figures

Length:	600, 1200 mm
Width:	600 mm (ceiling adaption available)
Height:	220 mm
Capacity:	769 W (Plexus IS/ISA-60) 992 W (Plexus IS/ISA-120)

Calculation setup

Room temp: 25°C, Water temp: 14-17°C, Air temp: 18°C,
Nozzle air pressure: 80 Pa, Air flow: 25 l/s.



2 way air pattern



4 way air pattern



Plexus 360° air pattern

Picture 1. Plexus integrates both cooling and heating functions from the climate beams together with the supply air terminals technique. Unique for the Plexus is that the air is supplied in a 360° air pattern instead of a traditional 4 way pattern. This feature allows approximately 30% shorter air throws.

Active chilled beam

Plexus

Function

Plexus works by the induction principle. The supply air is let in by induction Angled JetCone Nozzles directly controlled into a 360° sunflower shaped pattern.

The heated room air which is inducted through the cooling battery/coil is 4-5 times larger than the supplied primary air. The battery/coil consists of aluminium grills fitted onto CU-tubes where the cooled water runs through and thereby absorbs the rooms heated air, it is then let to a central cooling machine.

Lindab Pascal Water Solution VAV/DCV combined with active chilled beams

For an extra energy- and cost saving and environmentally friendly ventilation and cooling system, the Lindab Pascal Water solution should be applied. The Pascal solution will optimize the ventilation, cooling, heating and even lighting for a perfect indoor climate at the lowest running cost by combining the active chilled beam with VAV (Variable Air Volume) or DCV (Demand Controlled Ventilation) technique. Please refer to: [Pascal Water Solutions](#)

Hygiene

Plexus can as an option even be delivered with a partially down fold battery to ease access for cleaning all parts of the unit (picture 3).

Perforation pattern

The Plexus beam is available in two perforation pattern Dotx2 50% (standard) and Slot 50% (plus feature).

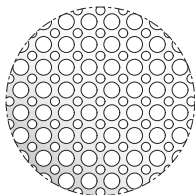

Dotx2 50%

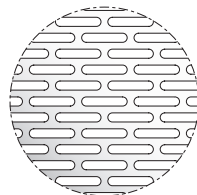

Slot 50%

Picture 2. Available perforation.



Picture 3. The battery is recessed and access to the whole unit is given. When you open the inspection panel, free access is given to the bigger parts of the product as well as the air duct system.

Cleaning hatch

Plexus comes as standard with an inspection and cleaning hatch, through this you can easily access the unit and ducts.

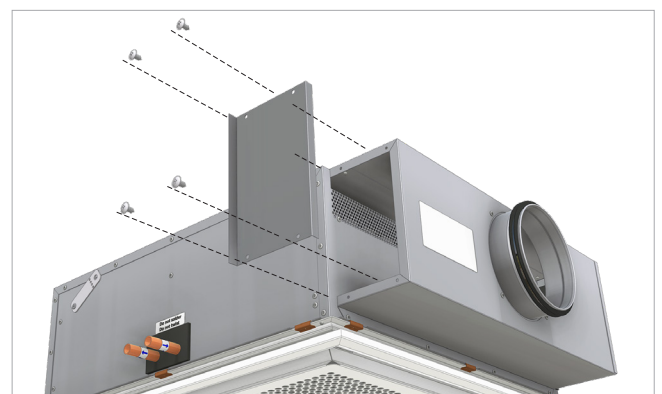

Picture 4. When the hatch is opened an easy access to the ducts is created.

Active chilled beam

Plexus

Construction

Plexus is developed and constructed to reach shortest possible air velocities in the comfort zone.

This is achieved by the Angled Nozzles which let the air spread into a 360° around the beam. Plexus is a comfort unit and is very compact in its design but still delivers optimal capacities and easy access for cleaning and inspection.

The water pipes are made of copper. The water flowing through the beam should always be free from oxygen to guarantee that corrosion does not occur.

Plexus IS, IL, IM, IH are provided with a high quality design outlet frame made from powder coated strang-aluminium.

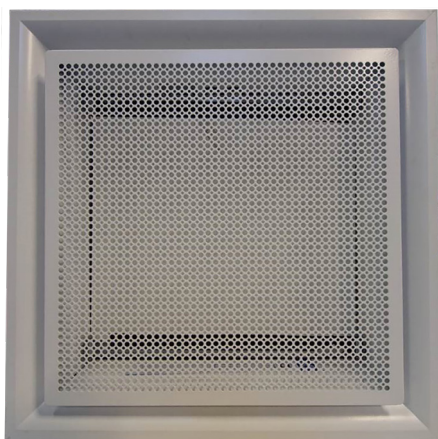

Picture 5.a Design model with aluminium outlet frame. (IS, IL, IM, IH).

The version ISA offers a good quality pre-coated steel casing incl. the outlet frame.

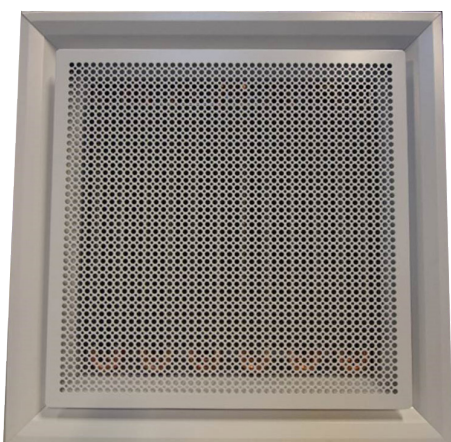

Picture 5.b Standard model ISA with pre-coated steel outletframe.

The perforated face plate is fitted in the height of the recessed ceiling, to give an aesthetic and complete integration in the ceiling.

Turnable battery

The water battery can be turned easily on side to change e.g. water connection (A5) to (A6) or vice versa (only available for 2-pipe connections and models without plus features).

The casing of the beam contains additional holes on the opposite side of the actual connections. These holes are closed by plastic end caps and must be opened before turning the battery. The remaining open holes must be closed, with these caps, afterwards to guarantee full function.

For further more detailed instruction please refer to: [Plexus installation instruction](#), 7.5 Turnable battery.

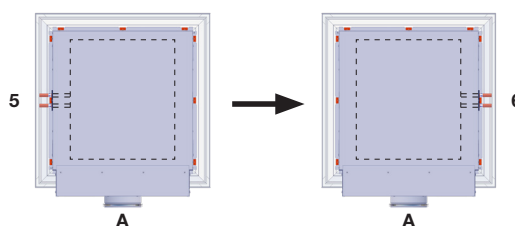

Picture 6. Changing standard Plexus A5 to A6.

Heating

Plexus can, as a plus feature, be equipped with Lindab's patented heating solution. By placing the heating coil in the end of the battery, instead of in the middle as normally on chilled beams, even better mixing ventilation is received and the vertical gradient will be distinguishly reduced. By placing the heating coil closest to for example a window, the down draughts will be reduced and the primary cooling source becomes eliminated fast and effective.

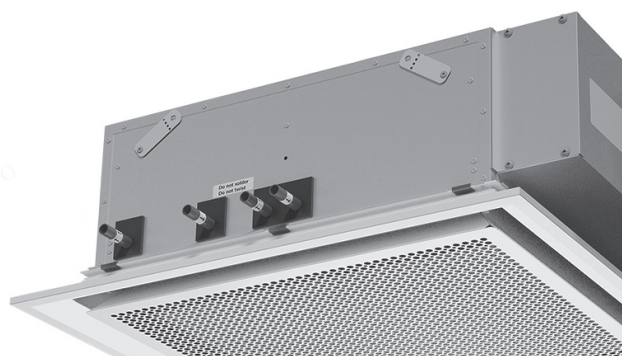

Picture 7. Plexus IS-60-A5 with heating solution.

Active chilled beam

Plexus

Adjustment JetCone

Plexus is delivered as standard with Lindab's JetCone air volume adjustment system. JetCone makes Plexus to a very flexible product with possibility of adjusting air diffusion, air volume and air pressure. Adjustment is made by setting the four adjustment regulators into different positions. The adjustment is done without any tools, which makes it very fast and easy. The fast adjustment system gives an opportunity within planning, since the product choice can be made in an early stage and the products can be drawn into the planning of the project even though the planner do not have all the required data.

To offer the best flexibility concerning the ventilation air volume, Plexus 60 can be ordered in four different types S/SA (standard), L (low), M (medium) and H (high).

The different types results in that Plexus receives different operating ranges for minimum and maximum air volume. By limiting the operating ranges in different configurations, you can with our JetCone adjustment system easily obtain a very accurate adjustment to requested air volume.

Type S/SA are Lindab's standard types which have a variable air volume capacity covering the most common demands. In configuration L, M and H we have combined the JetCone system with angled nozzles to be able to offer three predefined operating ranges. These operating ranges is overlapping each other to be able to give a very accurate regulation. Type L is predefined to the same operating range such as S, while M and H have a operating range which gives higher air volumes. The big advantage is that L, M and H easily can be re-configured and replace each other.

The difference between type L, M, H and type S/SA is that type S/SA can handle a higher nozzle pressure with low sound levels and gives a little bit higher capacities at those operating circumstances. Diagram 2 and 3 shows the capacity for the different types. Diagram 9, 10 and 11 shows the minimum and maximum air volume, and the sound level at the specific operating point.

Plexus 120 is only available in standard type S/SA.



Picture 8. Plexus IS-120-A5 with heating solution.

Example

Today one person is sitting in a cell office. The company is making an expansion and employes one more person, who should be placed in the same room. The air volume then needs to be adjusted to cover the fresh air requirement for two persons instead of one person. The air volume is adjusted by modifying the position of the adjustment point and the requested result is given. If it is requested to direct the air diffusion in a certain way this is also possible to do. With the JetCone adjustment system it is possible to get an asymmetric air pattern.

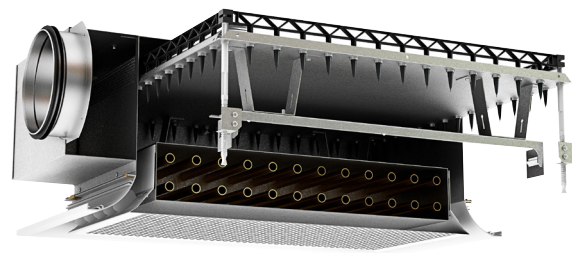

Picture 9. Lindab's JetCone system.

Optimal Diffusion Pattern

As the air is not supplied in parallel rays (stream), but in a sun shaped 360° pattern. The air rays (stream) never collide with the result of longer throws. Plexus has 30% shorter throws than similar products.

The significant shorter throw makes it possible to place the units closer together and thereby it is possible to supply much more cooling capacity to the room.

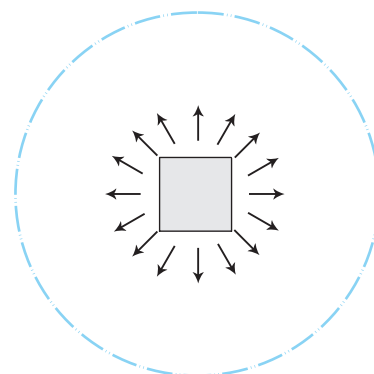

Picture 10. With Plexus you create all conditions for lower air velocities in the occupied zone which result in a climate without draughts in the most natural way.

Active chilled beam

Plexus

Data

Variants

The Plexus beam is a 360° comfort unit and is standardly prepared for ventilation and cooling (2-Pipe connection). It is available in an integrateable (I..60 / I..120) and an exposed version (F..60 / F..120).

Lengths/width: Plexus is available in 600 mm x 600 mm and 1200 mm x 600 mm.

Height: The height is 220 mm.

Water connection: The water connections for cooling are 12 mm.

Air connection: The air connection is available horizontal Ø125 mm or vertical Ø160 mm.

JetCone: The JetCone is standard feature. The factory settings will be done according to desired static pressure (Pa) and primary air flow (l/s) and can be changed easily on site.

Angled Nozzles: The Angled Nozzles are manufactured in an optimized fixed position (No visible fixed deflectors).

Design: Perforated with Dotx2 50%, perforation (see page 3). Plexus is provided with a high quality design outlet frame made from powder-coated strang-aluminium. The version ISA offers a pre-coated steel casing with integrated outlet frame.

Turnable Battery: The water battery can be turned easily on side to change e.g. water connection (A5) to (A6) or vice versa (only available for 2-pipe connections and models without plus features).

Surface treatment: Plexus is manufactured as standard from galvanised sheet metal and extruded aluminum (frame).

Adaptation for suspended ceilings: The product can be adapted to several suspended ceiling types as standard option (see page 2 and 19).

Note: The type ISA (integrated steel frame) is available for T24/T15 lay-in 600 (ceiling type 1) only!

Colour

The product is available as standard, in signal white RAL 9003 or in pure white RAL 9010, gloss value 30. Other RAL colours on request.

Pascal Water Solution

The beam can be easily integrated/used in a Pascal water system to enable VAV/DCV.

Please refer to: [Pascal Water Solution documentation](#).

Plus features

Factory preinstalled.

Heating: The product can be equipped with a water circuit, with 12 mm connections, in the battery to provide a heating function.

Enclosed valve and actuator: A control valve, with variable Kv value, and an actuator can be delivered with the product (when heating is needed, two sets of actuators and valves are needed).

Integrated Regula Secura: Lindab's Regula Secura condensation protection can be installed in the product.

Integrated Regula Connect: The product can be equipped with the Regula Connect connection card. Please see the Regula chapter for further information.

Adaptation for suspended ceilings: The product can be adapted to most types of suspended ceilings offered on the market.

Note: The type ISA (integrated steel frame) is available for T24/T15 lay-in 600 (ceiling type 1) only!

Design: There is another perforation pattern available Slot 50% (see page 3).

Down fold battery: Requires connection with flex hose. Battery runs down about 20 cm at the other end.

Special model: Plexus can also be delivered for ventilation only (without cooling battery).

Integrated control centre: It is possible to have Lindab's room control centre Regula pre-installed in the product. The control panel is fully accessible from below. Refer to the chapter Regula.

Accessories

Delivered separately.

Control: Refer to the chapter Regula.

Hangers: For recommended installation principles (see: "[Plexus Installation Instruction](#)").

All these different hangers are available at Lindab:

- pendulum hangers (in different sizes)
- threaded rods M8
- wiring hanger system

For additional accessories please refer to the "Accessories" document on www.lindab.com.

Active chilled beam

Plexus

Dimensioning

Cooling capacity air Pa

1. Start by calculating the capacity required for the room, to keep a certain temperature. Lindab's TEKNOsim is an excellent tool for this.
2. Calculate which cooling capacity, or read in diagram 1, that is supplied by the ventilation air.
3. Remaining cooling capacity needs to be cooled by the water circuit in Plexus.

The formula for calculating the capacity of the air:

$$Pa = q_{ma} \times c_{pa} \times \Delta t_{ra}$$

Size comparison by $t_r = 25^\circ\text{C}$ with:

$$Pa \text{ [W]} = q_a \text{ [l/s]} \times 1.2 \Delta t_{ra} \text{ [K]}$$

$$Pa \text{ [W]} = q_a \text{ [m}^3\text{/h]} \times 0.33 \Delta t_{ra} \text{ [K]}$$

Minimum flow

Please note that flows below the recommended minimum water flow q_{wmin} , can result in unwanted air in the water pipes. Exceeding the nominal flows q_{wnom} is not recommended as the capacity gains will only be minimal.

Pipe diameter	q_{wmin}	q_{wnom}
12 mm	0.025 l/s*	0.038 l/s

* only valid for Plexus 60, cooling 2-pipe system.

Definitions:

- Pa = Cooling capacity air [W]
- P_w = Cooling capacity water [W]
- P_{tot} = Cooling capacity total [W]
- q_{ma} = Air mass flow rate [kg/s]
- q_a = Primary air flow rate [l/s]
- q_w = Water flow rate [l/s]
- q_{wmin} = Minimal water flow rate [l/s]
- q_{wnom} = Nominal water flow rate [l/s]
- c_{pa} = Specific heat capacity air [1.004 kJ/kg K]
- t_r = Room air temperature [°C]
- t_{wi} = Water inlet temperature [°C]
- t_{wo} = Water outlet temperature [°C]
- Δt_{ra} = Temp. diff., room air and primary air temp. [K]
- Δt_{rw} = Temp. diff., room air and mean water temp. [K]
- Δt_w = Temp. diff. water circuit [K]
- ε_{Δtw} = Capacity correction for temperature
- ε_{qw} = Capacity correction for water flow
- P_{Lt} = Specific cooling capacity [W/K]

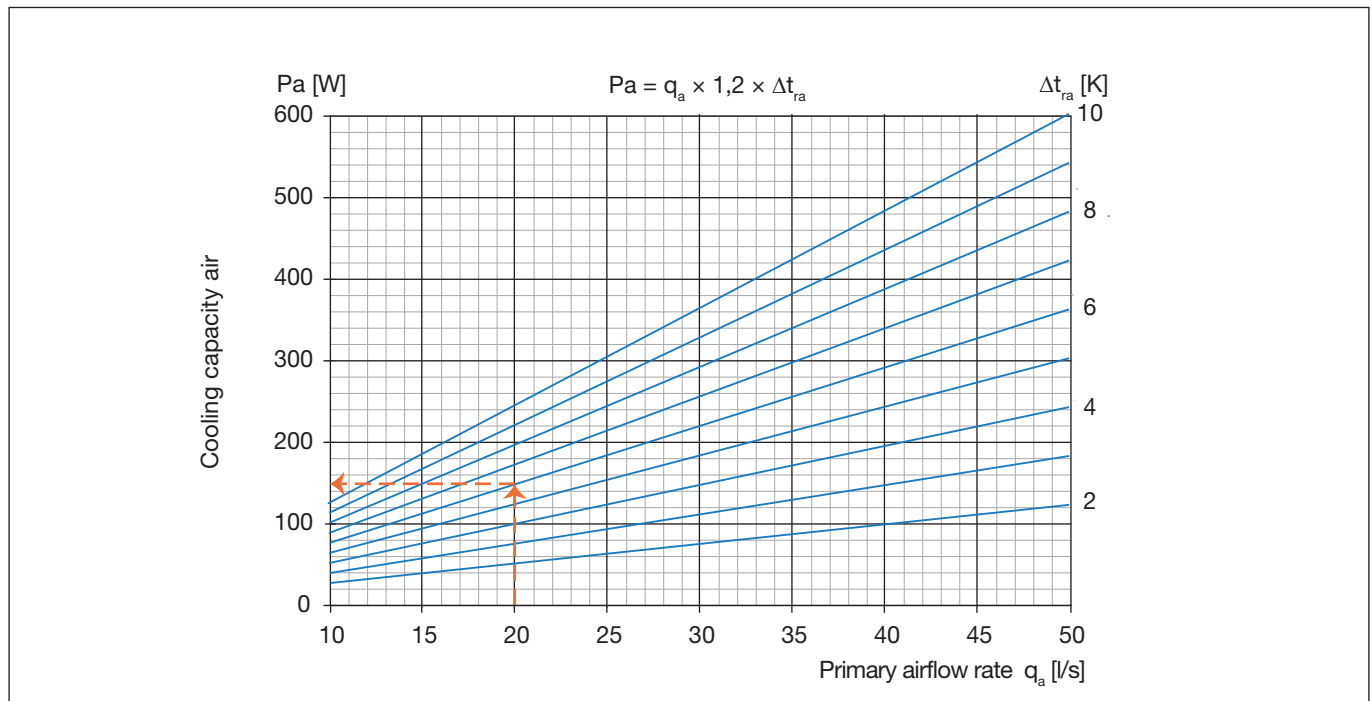

Diagram 1. Cooling capacity air Pa, as function of the primary airflow rate qa. If the air supply is 20 l/s and the temperature difference of the room air and the supply air is Δtra = 6 K, then the cooling capacity is 144 W.

Active chilled beam

Plexus

Dimensioning

Cooling capacity water P_w

In order to calculate the cooling capacity water P_w the diagrams 2-5 are used in the following way.

1. Calculate $\Delta t_{rw} = t_r - (t_{wi} + t_{wo})/2$.
2. Find the specific cooling capacity P_T in diagram 2, 3 or 4.
3. Find the capacity correction factor $\epsilon_{\Delta tw}$ in diagram 5. (Only applies for Plexus 60).
4. Multiply the cooling capacity with Δt_{rw} and $\epsilon_{\Delta tw}$.

Example 1 Cooling:

Which capacity does a Plexus IS/ISA 60 give with an air flow of 20 l/s and a static pressure of 60 Pa?

Temperature conditions:

$$\Delta t_{rw} = 10 \text{ K}, \Delta t_w = 3 \text{ K}, \Delta t_{ra} = 6 \text{ K}$$

Diagram 2 shows a specific cooling capacity with the value $P_T = 51.8 \text{ W}$.

Diagram 5 shows a capacity correction factor $\epsilon_{\Delta tw} = 0.968$.

This gives a cooling capacity:

$$P_w = 51.8 \text{ W/K} \times 10 \text{ K} \times 0.968 = 501 \text{ W in the water circuit.}$$

From diagram 1, the cooling capacity air is calculated:

$$P_a = 20 \text{ l/s} \times 1.2 \times 6 \text{ K} = 144 \text{ W}$$

This gives a total cooling capacity:

$$P_{tot} = 144 \text{ W} + 501 \text{ W} = 645 \text{ W.}$$

NB! The capacity diagram applies for the nominal water flow of $q_{wnom} = 0.038 \text{ l/s}$. To obtain the right cooling capacity P_w at other flows, read off the capacity correction factor ϵ_{qw} from diagram 8 and multiply the capacity, which is read off, by this factor as shown in example 2 for heating.

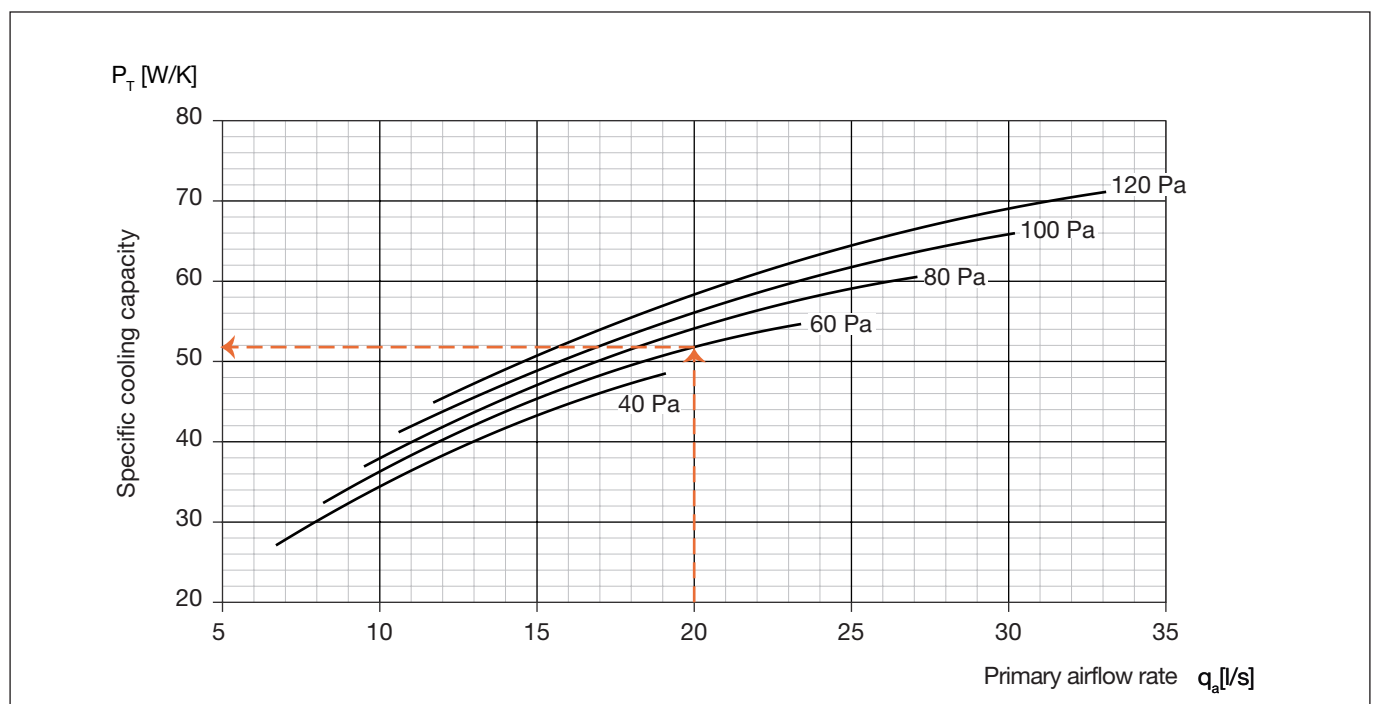

Diagram 2. Plexus 60 all models configuration S/SA. Specific cooling capacity P_T is reduced with 6% when using battery with both cooling and heating.

Active chilled beam

Plexus

Diagrams - Specific Cooling Capacity

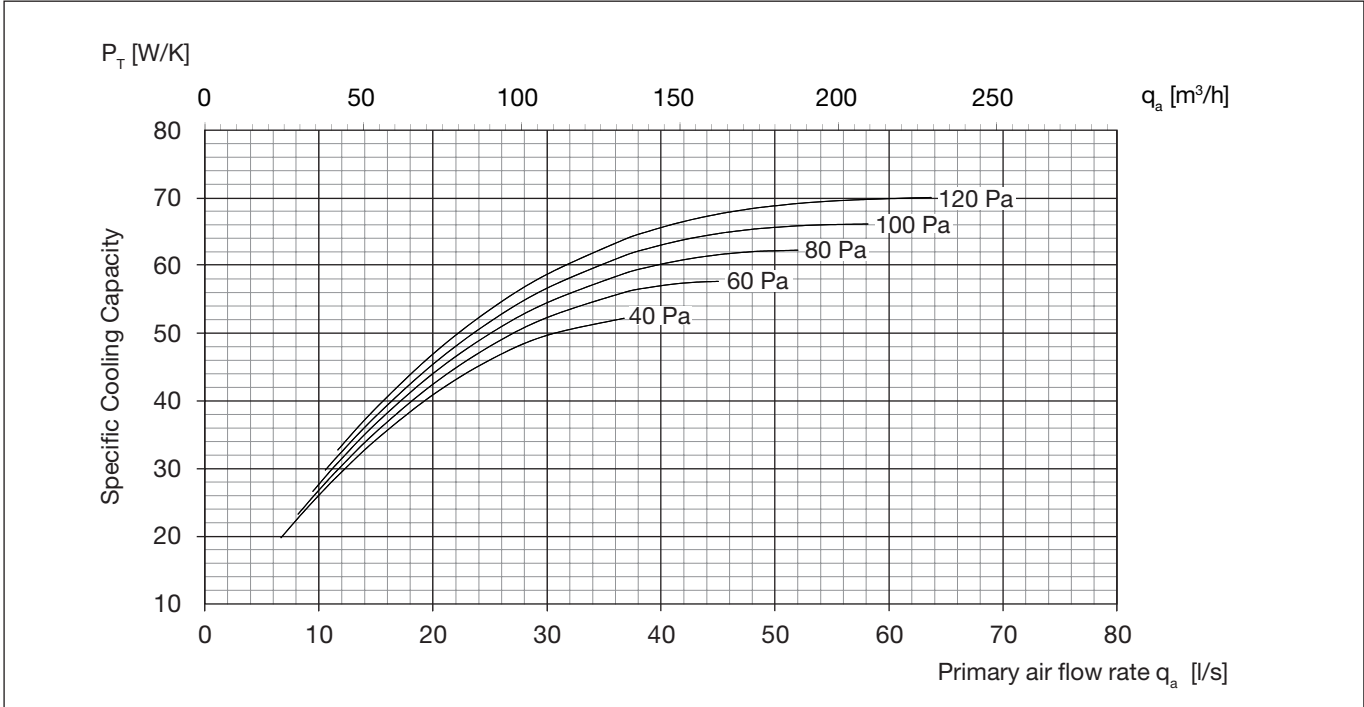

Diagram 3. Plexus 60 all models configuration L/M/H. Specific cooling capacity P_T is reduced with 6% when using battery with both cooling and heating.

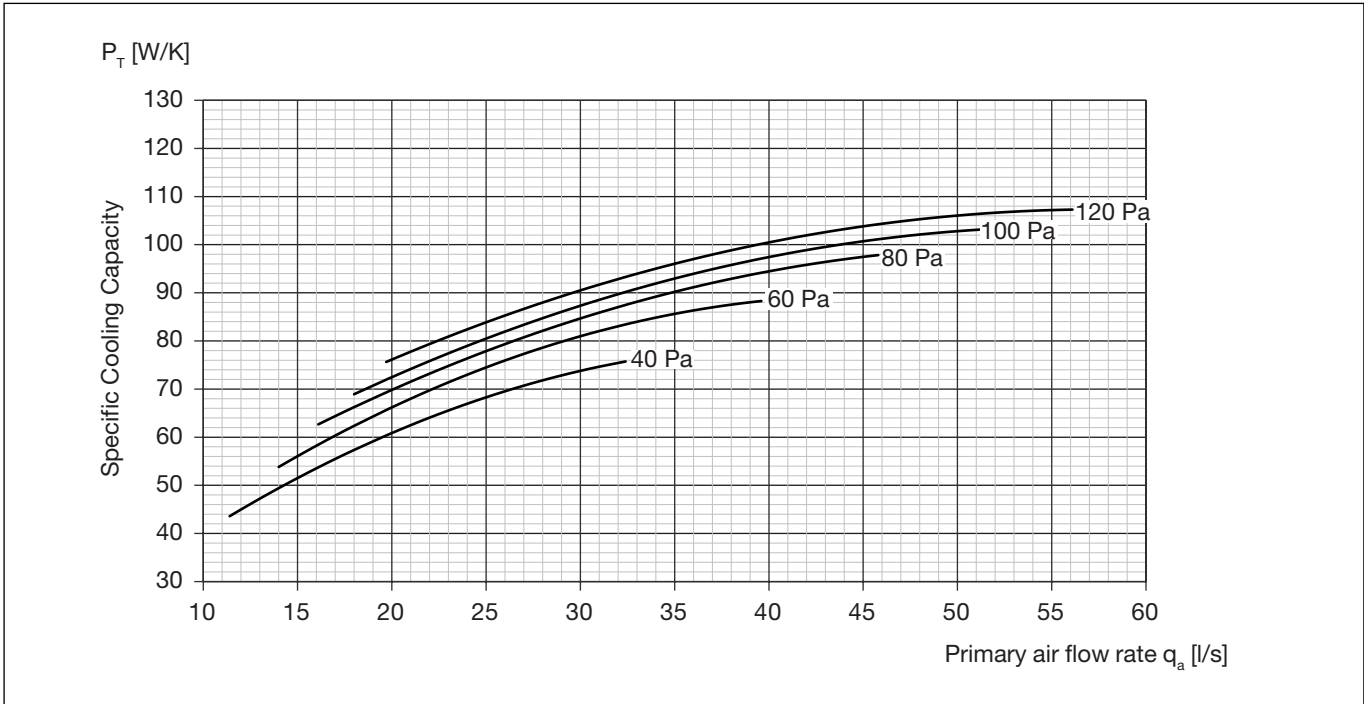

Diagram 4. Plexus 120 all models configuration S/SA.

Active chilled beam

Plexus

Diagram Capacity Correction

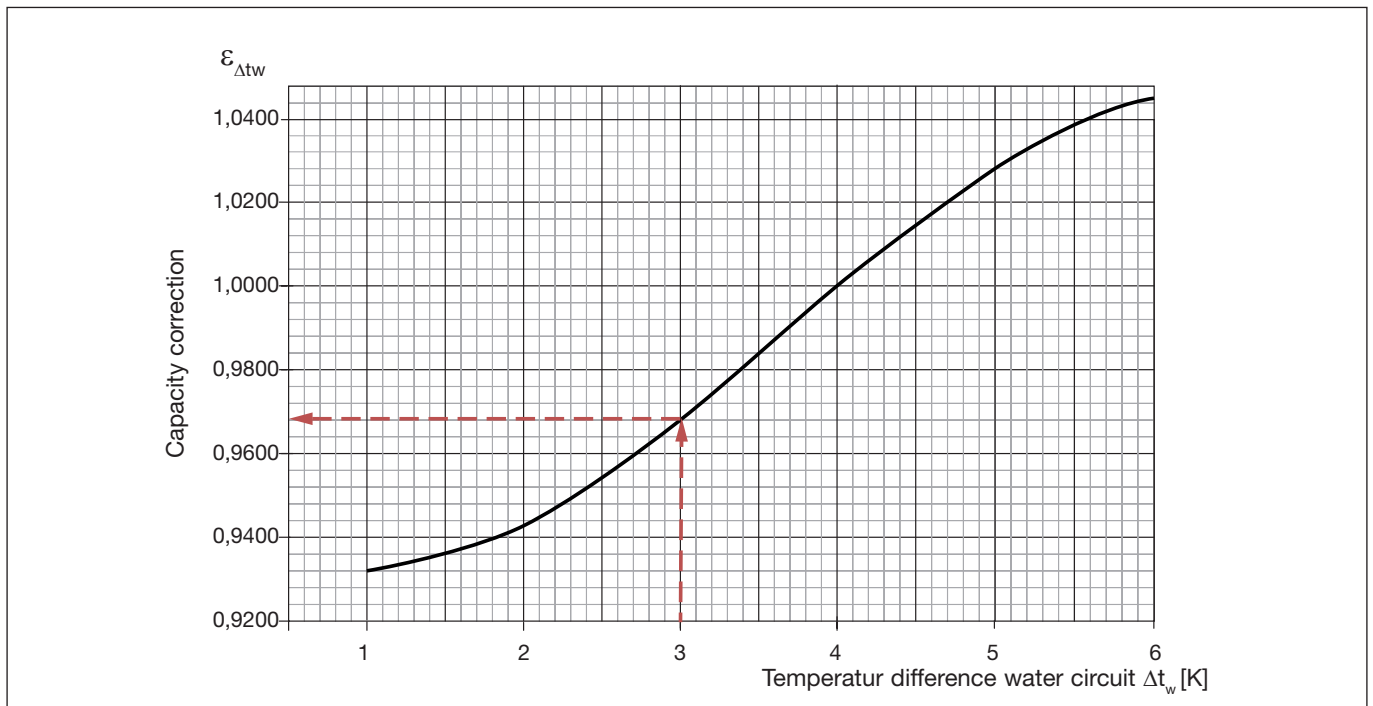

Diagram 5. Capacity correction $\epsilon_{\Delta t_w}$ as a function of Δt_w . Only applies for 2-pipe system, cooling or heating on Plexus 60.

Capacities on Natural Convection

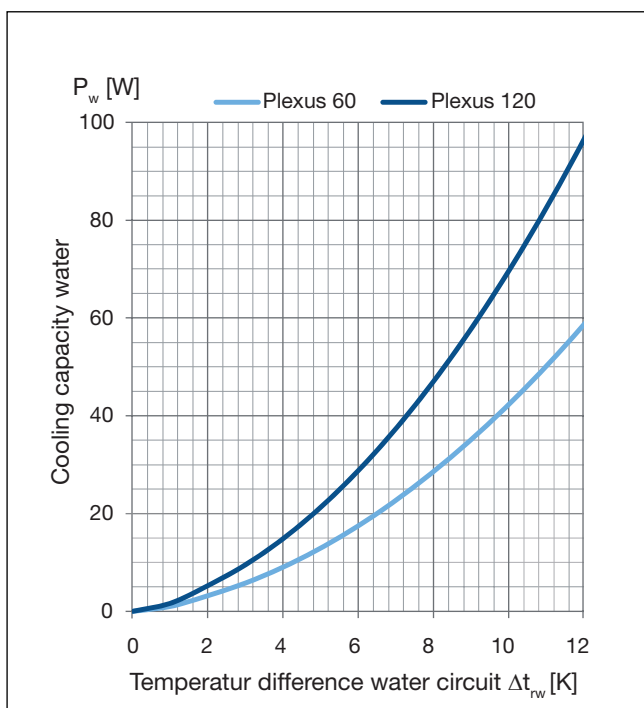

Diagram 6. Plexus natural convection capacity cooling at nominal water flow 0.038 l/s.

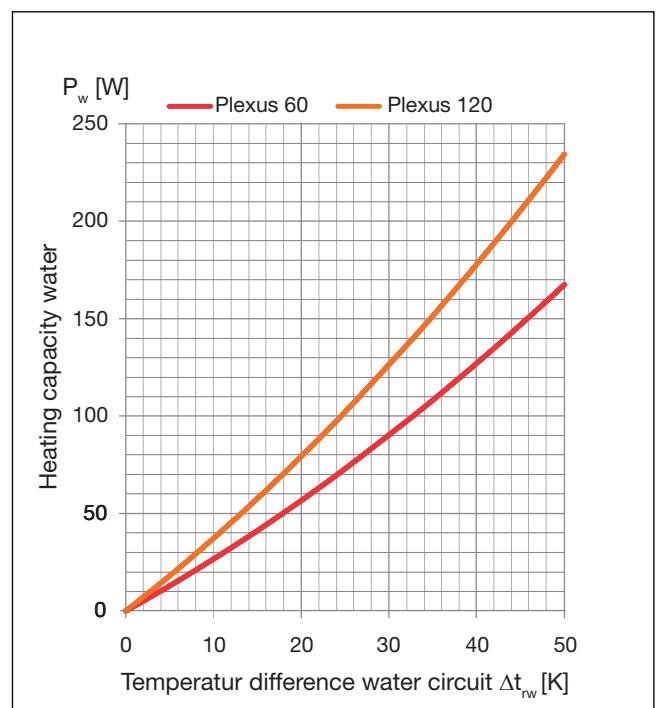

Diagram 7. Plexus natural convection capacity heating at nominal water flow 0.019 l/s.

Active chilled beam

Plexus

Dimensioning

Capacity correction for water flow ϵ_{qw}

Example 2 Heating:

Which heating capacity does a Plexus IS/ISA 60 give with an airflow of 20 l/s and a static pressure of 60 Pa?

Temperature conditions:

$$\Delta t_{rw} = 24 \text{ K}, \Delta t_w = 3 \text{ K}, \Delta t_{ra} = 0 \text{ K}$$

We have to start as in example 1 with finding out specific cooling capacity. Diagram 2 shows a specific (cooling) capacity with the value $P_T = 51.8 \text{ W/K}$.

Since we use a battery with both cooling and heating, the capacity P_T must be reduced with 6%:

$$P_T = 51.8 \times 0.94 = 48.7 \text{ W/K}$$

This gives a water capacity:

$$P_w = 48.7 \text{ W/K} \times 24 \text{ K} = 1169 \text{ W in the water circuit.}$$

Using the heating curve in diagram 8 for capacity correction ϵ_{qw} leads us to the heating capacity.

Water flow rate:

$$q_w = 1169 \text{ W} / (4200 \text{ Ws/(kg K)} \times 3 \text{ K}) = 0.093 \text{ l/s.}$$

Then the capacity correction factor: $\epsilon_{qw} = 0.42$.
Obtained capacity: $P_w = 1169 \text{ W} \times 0.42 = 491 \text{ W}$.

The new water flow is calculated:

$$q_w = 491 \text{ W} / (4200 \text{ Ws/(kg K)} \times 3 \text{ K}) = 0.039 \text{ l/s.}$$

Then the new capacity correction factor $\epsilon_{qw} = 0.41$.

Obtained capacity: $P_w = 1169 \text{ W} \times 0.415 = 485 \text{ W}$.

Calculate again:

$$q_w = 485 \text{ W} / (4200 \text{ Ws/(kg K)} \times 3 \text{ K}) = 0.039 \text{ l/s.}$$

The new capacity correction factor is shown as 0.415.

Then the new obtained capacity is:

$$P_w = 1169 \text{ W} \times 0.415 = 485 \text{ W.}$$

Seeing that the flow is near stable at this point in the calculation, the new heating capacity water is now:

$$P_w = 485 \text{ W.}$$

From the calculated water flow the corrections factor ϵ_{qw} is determined for the efficiency of utilization. The calculations are repeated until calculated capacity in roughly matches earlier calculations. Corrected capacity is easily calculated with [Product Calculator Water](#) in Lindab's Quick Selection Tool – lindQST.com.

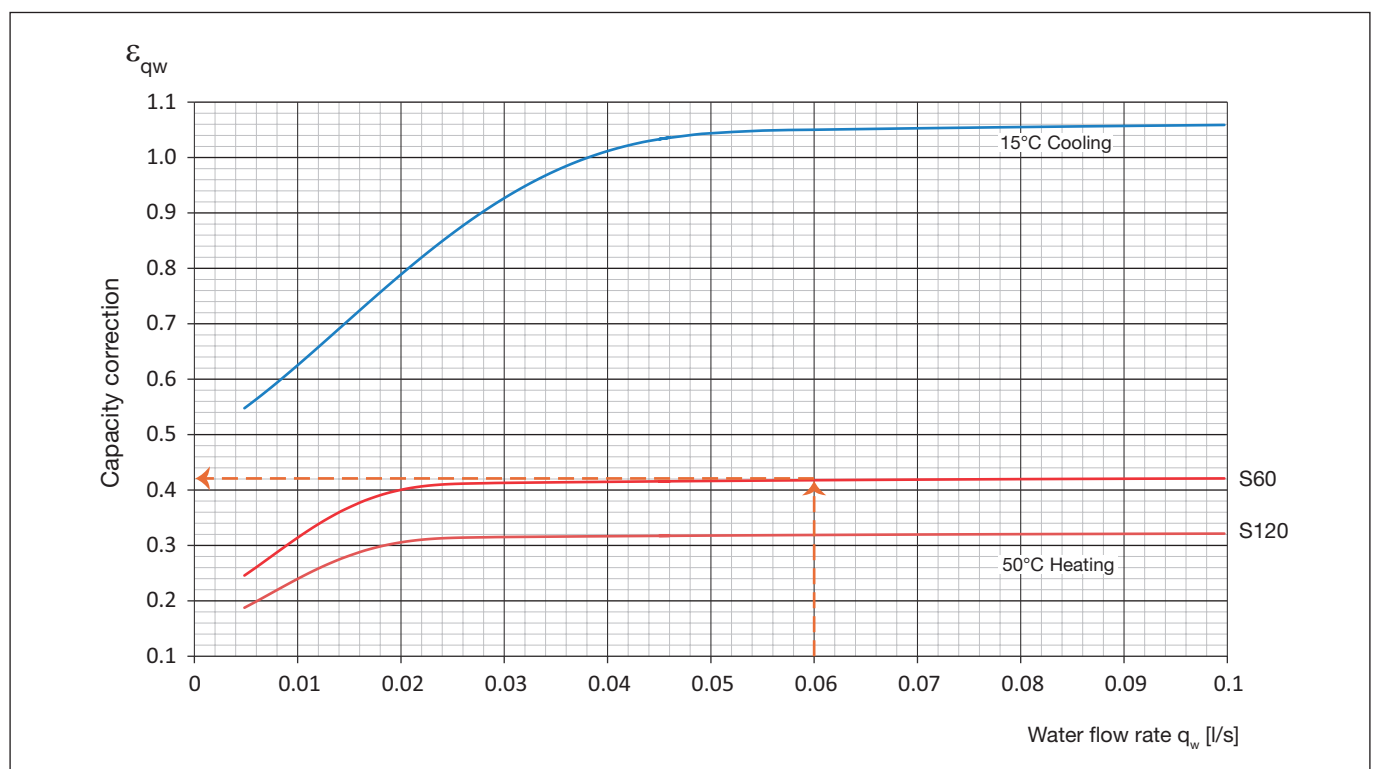

Diagram 8. Capacity correction for water flow ϵ_{qw} for both heating and cooling.

Active chilled beam

Plexus

Dimensioning Sound

In order to read the sound power level L_{WA} for the Plexus one must use the total pressure in the inlet Δp_t , and the current air flow rate q_a .

The total pressure loss Δp_t , is calculated by taking the static pressure before the nozzles Δp_{stat} in the fittings and adds the pressure difference Δp_a . Δp_a can be read in diagram 9.

Now you can read the actually sound effect level L_{WA} in diagrams 10 to 12.

The sound values in parenthesis is the sound pressure level L_{pa} at 4 dB room silencer (10 m² Sabine).

Example 5:

Plexus IS/ISA 60 with a primary air quantity q_a on 20 l/s and a static pressure in the nozzles Δp_{stat} on 60 Pa.

- From diagram 9 show at $q_a = 20$ l/s a value for $\Delta p_a = 4$ Pa
 $\Delta p_t = 60 \text{ Pa} + 4 \text{ Pa} = 64 \text{ Pa}$

Total pressure loss $\Delta p_t = 60 + 4,0 \approx 64 \text{ Pa}$.

- In diagram 10, it reads as $q_a = 20$ l/s and $\Delta p_t = 64 \text{ Pa}$ with a sound power level L_{WA} on 25 dB(A).
- Furthermore you can read in the diagram, that the setting point must be set at 6.5. It can only be set without decimals and there is 4 settings points, which results in two settings points which must be set at 7 and two settings points at 6 by the current air quantity and pressure level.

Sound attenuation ΔL

Plexus attenuation ΔL [dB], between air duct and room including end-reflection.

Sound data

Plexus	63Hz	125Hz	250Hz	500Hz	1kHz	2kHz	4kHz	8kHz
IS/ISA 60	15	14	6	10	7	6	9	17
IL/M/H 60	17	11	3	7	4	5	7	13
IS/ISA 120	17	12	3	10	8	7	9	18

Table 1. Plexus's internal sound dampening.

Noise level K_{ok}

Plexus noise levels for each octave band in the beam are calculated by adding the corrections K_{ok} from the table below to the sound power level L_{WA} [dB(A)].

Plexus	63Hz	125Hz	250Hz	500Hz	1kHz	2kHz	4kHz	8kHz
IS/ISA 60	12	-3	-4	-4	-4	-8	-11	-16
IS/ISA 120	11	-1	-1	-2	-5	-9	-15	-20
IL 60	12	-4	-4	-5	-4	-7	-14	-20
IM 60	11	-5	-3	-3	-4	-8	-17	-18
IH 60	10	-2	-1	-1	-4	-12	-21	-18

Table 2. Plexus's noise levels $L_{w_{oct}}$ for each octave band in the beam, are calculated by adding the corrections C_{oct} from the table above to the sound power level L_{wa} dB(A). The noise levels are calculated using the following formula:
 $L_{w_{oct}} = L_{wa} + C_{oct}$

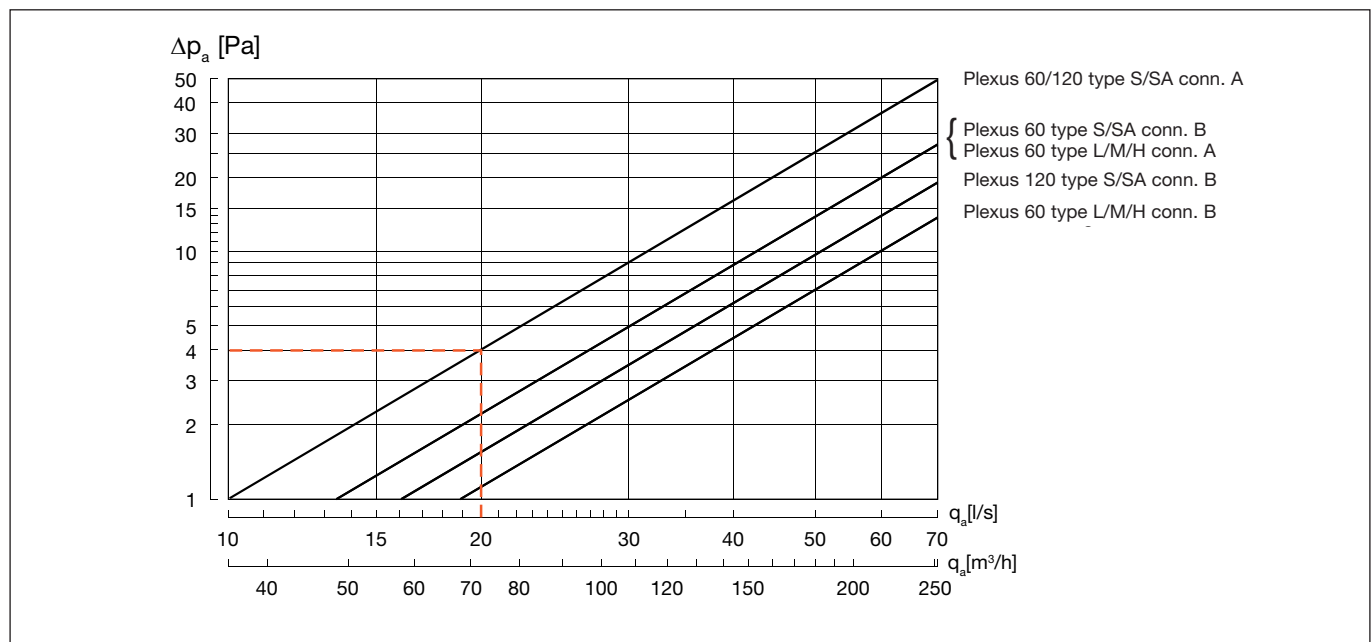

Diagram 9. Difference between the total pressure and the static pressure before the nozzles.

Active chilled beam

Plexus

Diagram, sound

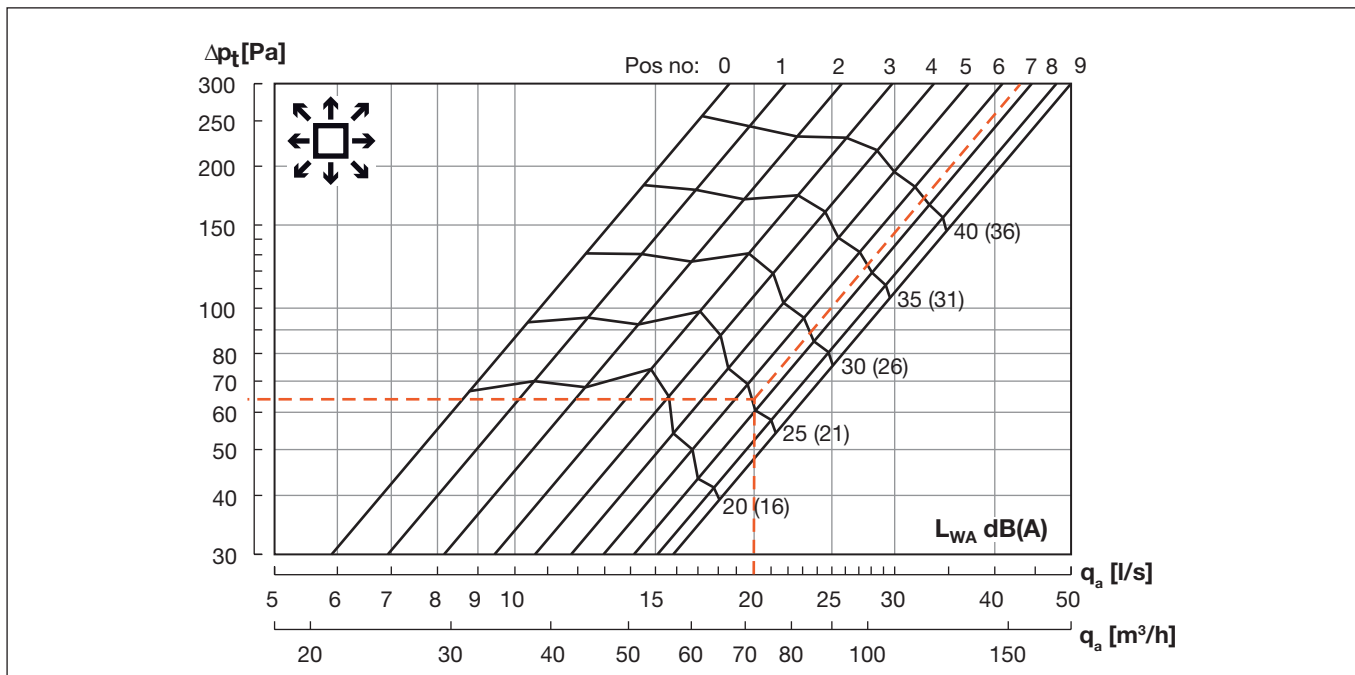

Diagram 10. Sound power level L_{WA} Plexus 60 all models configuration S/SA.

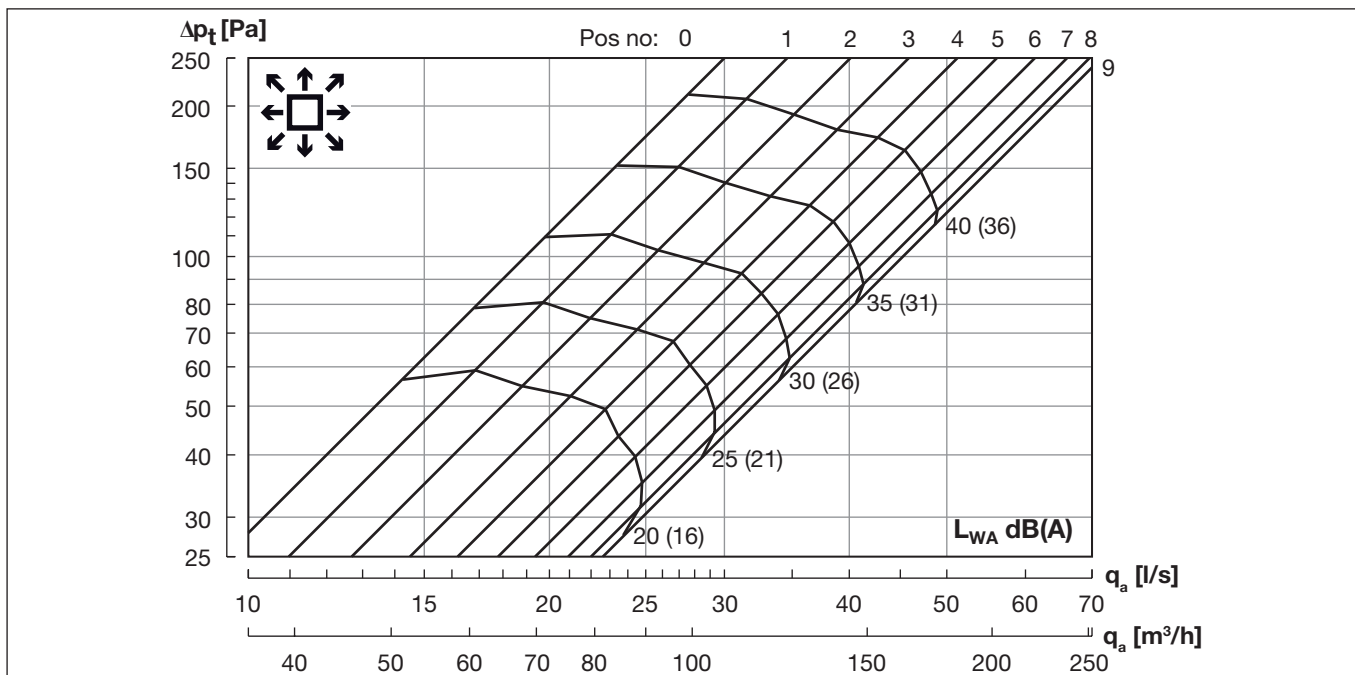

Diagram 11. Sound power level L_{WA} Plexus 120 all models configuration S/SA.

Active chilled beam

Plexus

Diagram, sound

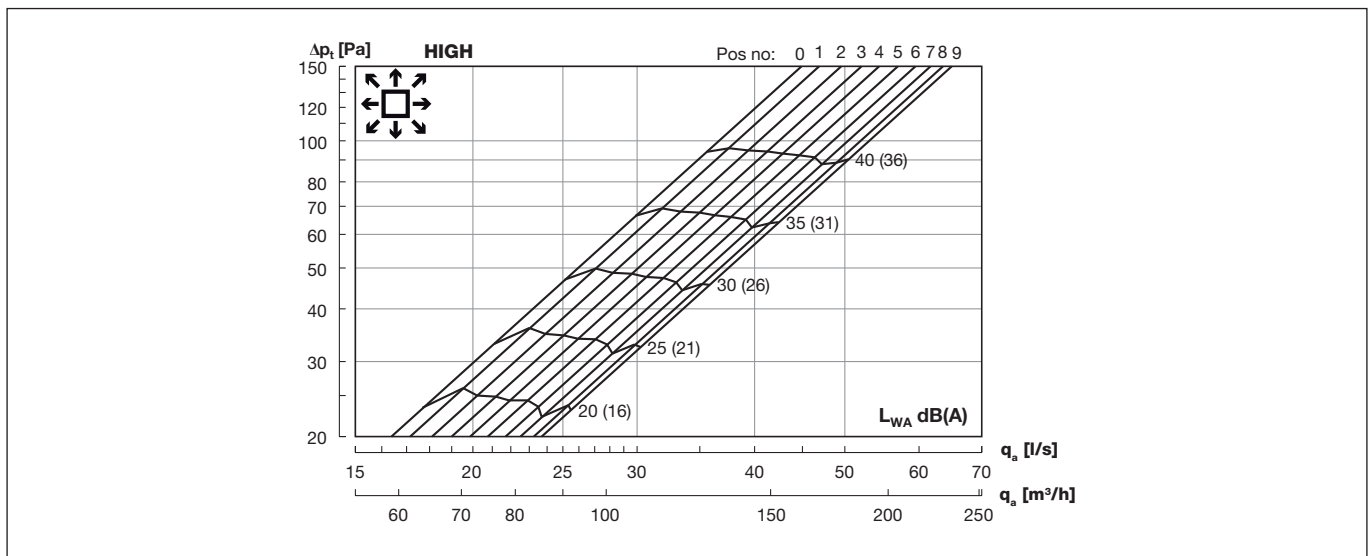
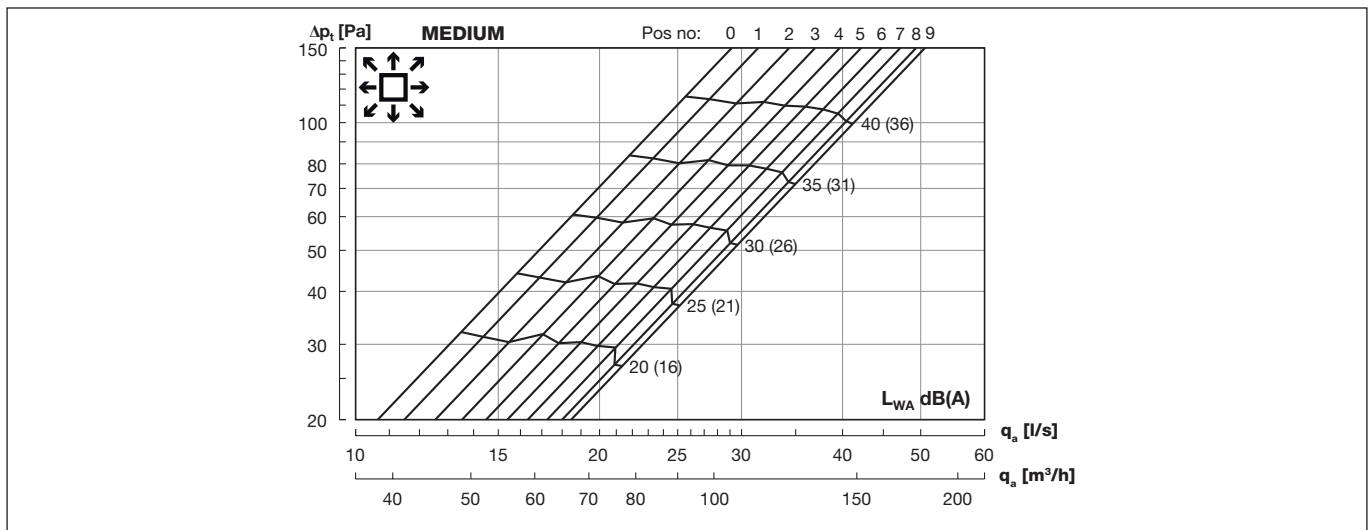
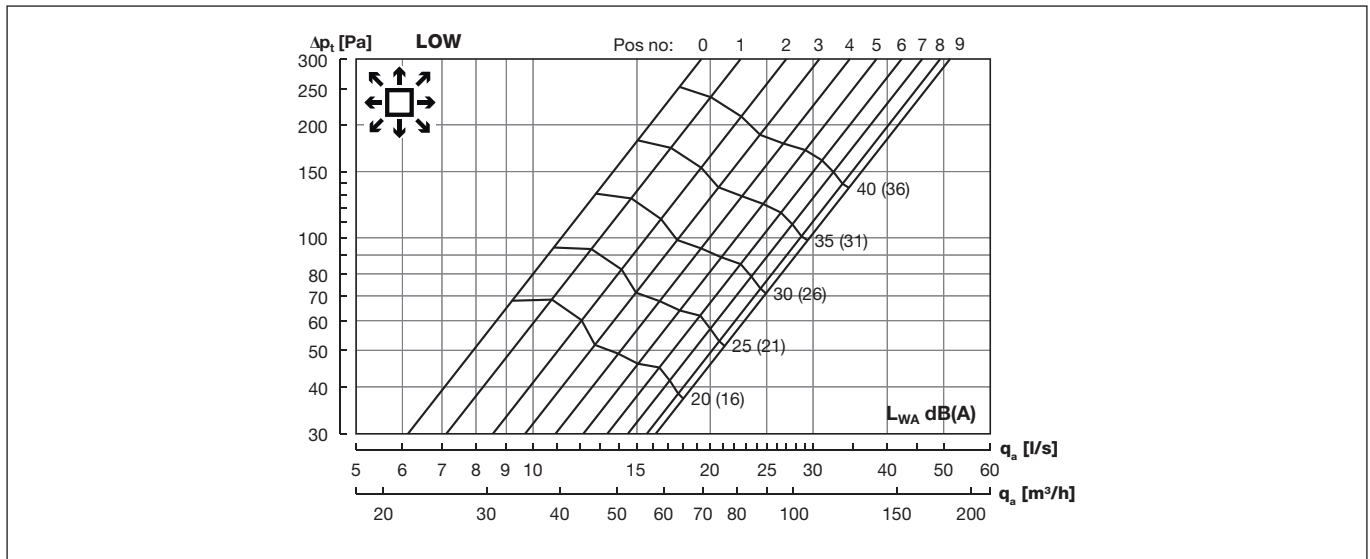

Diagram 12. Sound power level L_{WA} for Plexus 60 all models configuration Low/Medium/High.

Active chilled beam

Plexus

Throw lengths

Plexus 60 $\Delta t_{ra} = 6K, \Delta t_{rw} = 8K$

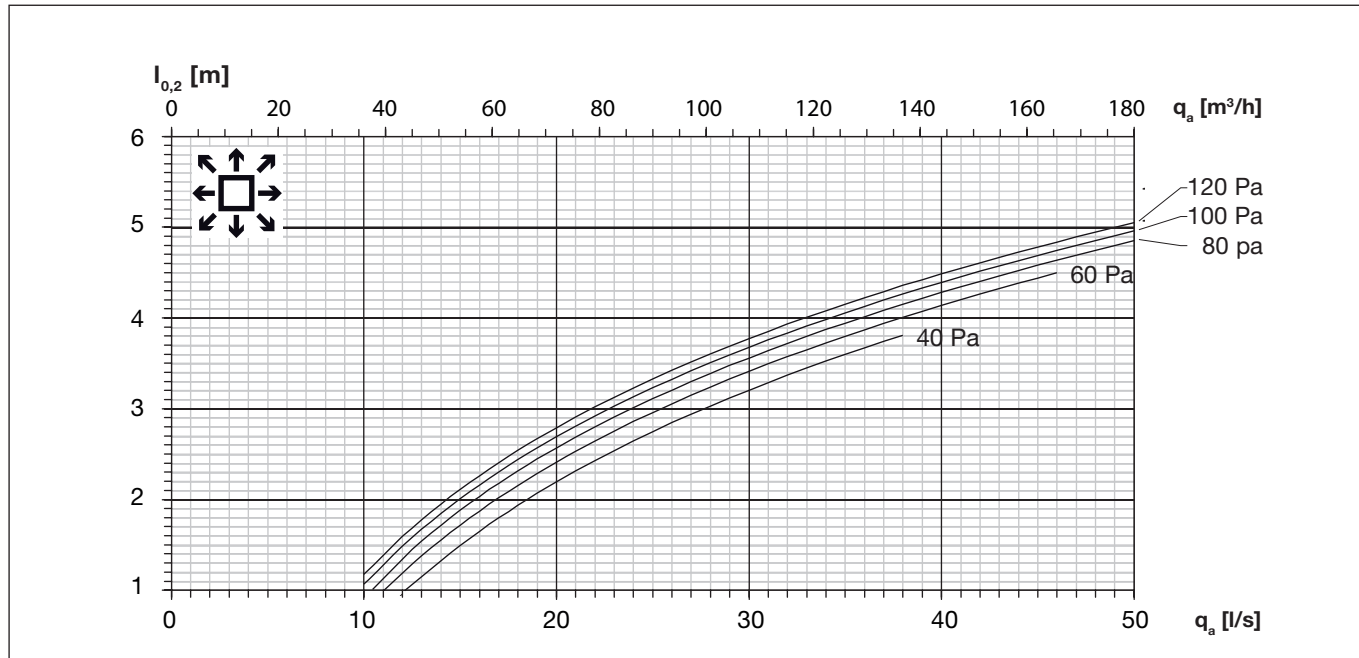

Diagram 13. Plexus 60 (not F 60), defined by given under temperature.

Δt_{ra} = Temp. diff., room air and primary air temperature [K].
 Δt_{rw} = Temp. diff., room air and mean water temperature [K].

Plexus 120 $\Delta t_{ra} = 6K, \Delta t_{rw} = 8K$

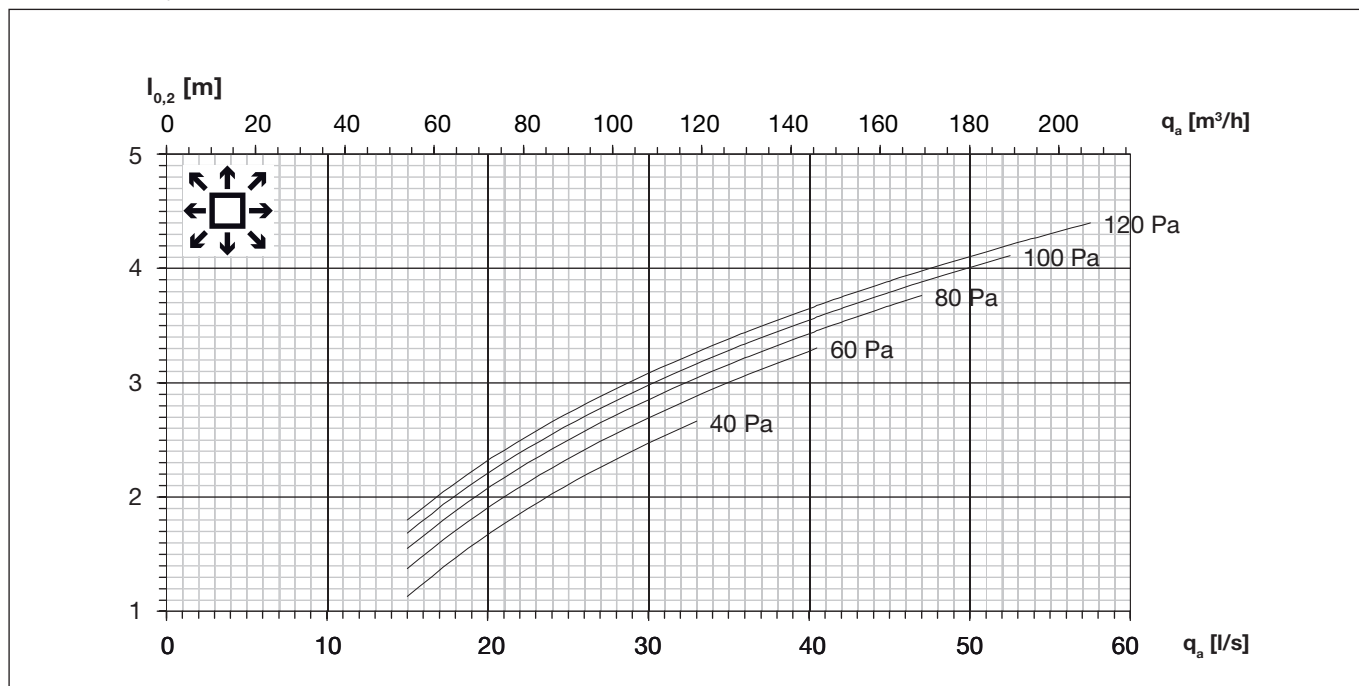

Diagram 14. Plexus 120 (not F 120), defined by given under temperature.

Δt_{ra} = Temp. diff., room air and primary air temperature [K].
 Δt_{rw} = Temp. diff., room air and mean water temperature [K].

Active chilled beam

Plexus

Throw lengths

Plexus F 60 $\Delta t_{ra} = 6K$, $\Delta t_{rw} = 8K$

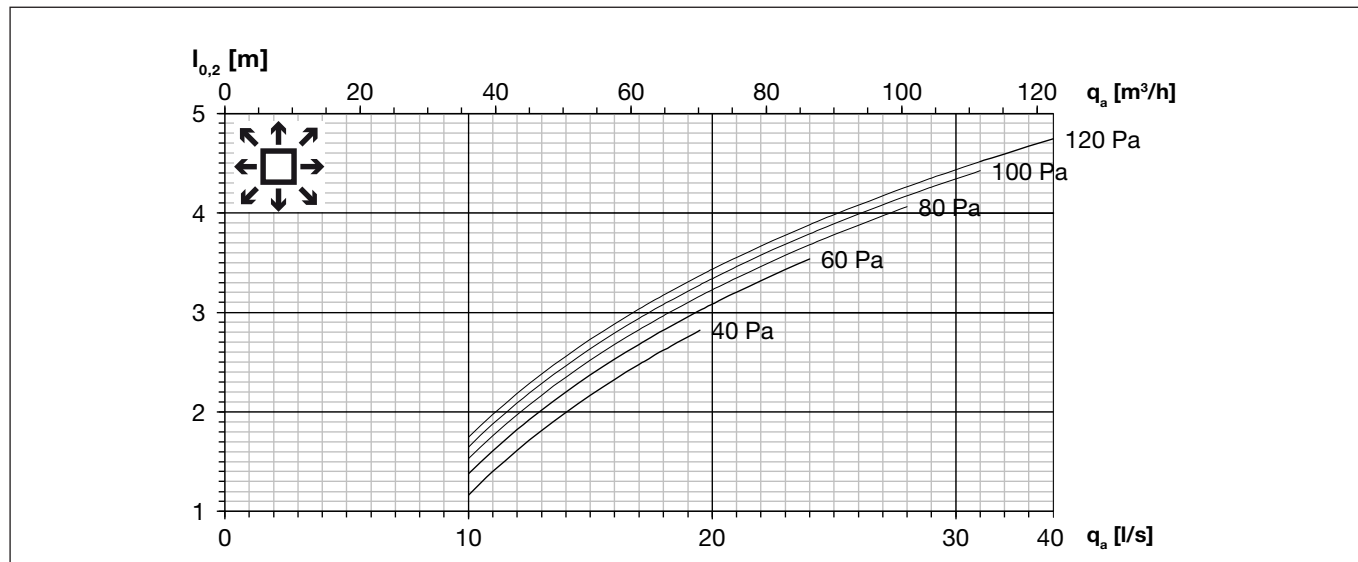

Diagram 15. Plexus F 60, defined by given under temperature.

Δt_{ra} = Temp. diff., room air and primary air temperature [K].
 Δt_{rw} = Temp. diff., room air and mean water temperature [K].

Type	Plexus I 60	Plexus I 120		Plexus F 60	Plexus F 120	
	Cooling/Heating	Cooling/Heating		Cooling/Heating	Cooling/Heating	
Dry weight, kg	11.6	18.6	20	17.2	28.9	30.3
Water content, cooling, l	1.0	1.3		1.0	1.3	
Water content, heating, l	0.2	0.4		0.2	0.4	
Water content, cooling only, l	1.2	1.3		1.2	1.3	
Copper pipes, quality	EN 12735-2 CU-DHP					
Pressure class	PN10					

Table 3. Plexus's weight and water volume.

Active chilled beam

Plexus

Connections

Plexus 60: I, (X, Y, Z)

Water connection Ø12 mm.
 Supply air connection Ø125 mm (A),
 alternatively S Ø125 mm (B),
 L/M/H Ø160 mm (B).

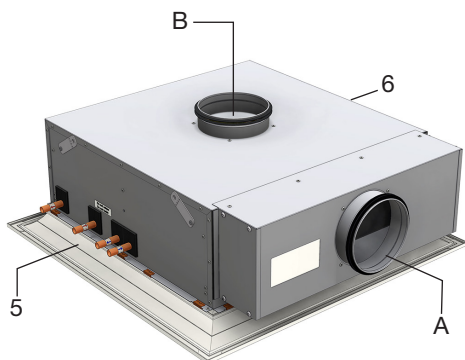

Picture 11. Plexus I-60 connections. Cooling and heating.

Plexus 120: I, (X, Y, Z)

Water connection Ø12 mm.
 Supply air connection Ø125 mm (A),
 alternatively Ø160 mm (B).

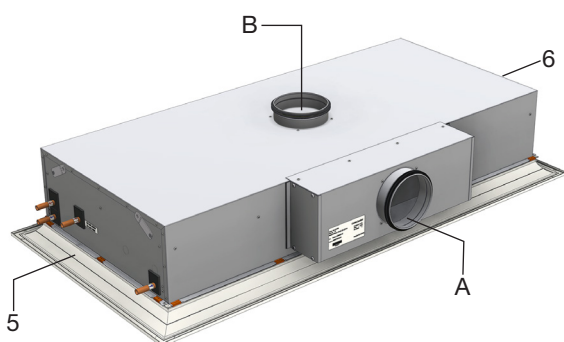

Picture 12. Plexus I-120 connections. Cooling and heating.

Example of water connections

The Pictures to the left show the connection possibilities A5, A6, B5 and B6 for Plexus I. Alternative A5, has horizontally connection for ventilation and water connection at the left side, seen in the direction of the air connection. When the plus feature heating is selected the heating connections are placed in the opposite side, to the left for connection 5 and to the right for connection 6. For air connection type B the heating connections are placed such as for type A, as illustrated on the drawings.

Plexus 60

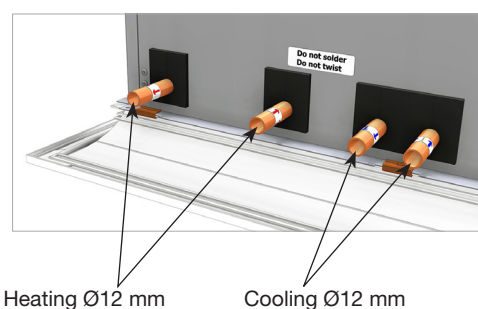

Picture 13. Water connections Plexus I-60. Cooling and heating.

Plexus 120

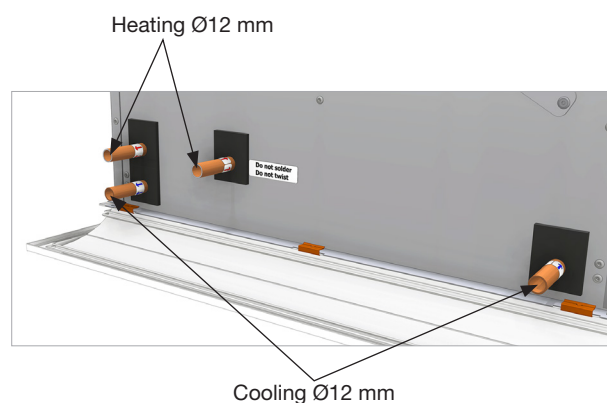

Picture 14. Water connections Plexus I-120. Cooling and heating.

Active chilled beam

Plexus

Connections

Plexus F 60

Water connection $\varnothing 12$ mm.
 Supply air connection $\varnothing 125$ mm (A),
 alternatively S $\varnothing 125$ mm (B),
 L/M/H $\varnothing 160$ mm (B).

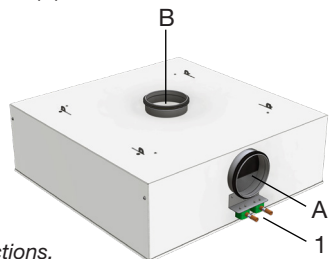

Picture 15.a Plexus F-60 connections.

Plexus F 120

Water connection $\varnothing 12$ mm.
 Supply air connection $\varnothing 125$ mm (A),
 alternatively $\varnothing 160$ mm (B).

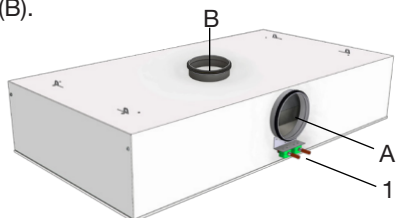

Picture 15.b Plexus F-120 connections.

Example of Water Connections

The picture to the left shows standard connection possibilities A1 and B1 Plexus F. Air connection type A is for horizontal and type B is for vertical air connection.

For other special connections, please contact your local lindab dealer.

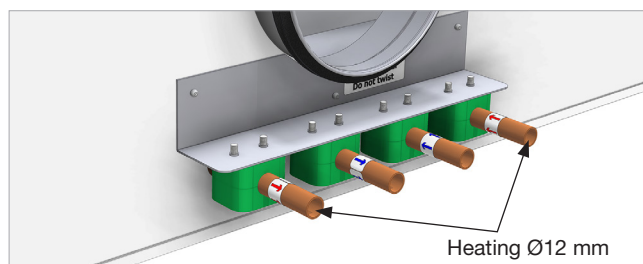
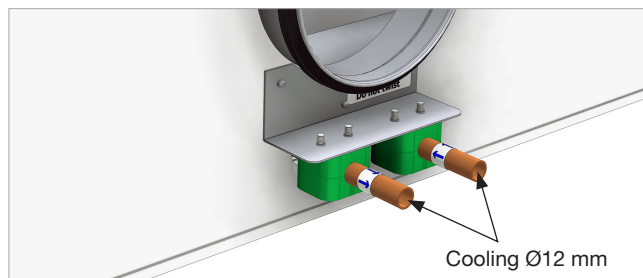

Picture 16. Cooling and heating connections Plexus F-60 / F-120.

Plexus F dimensions

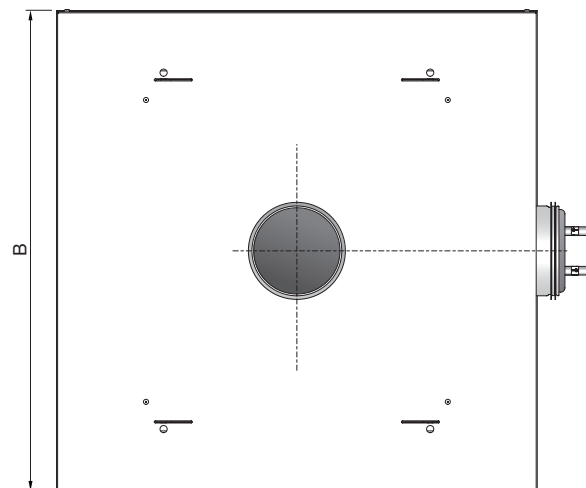
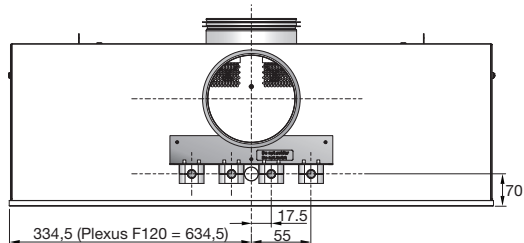
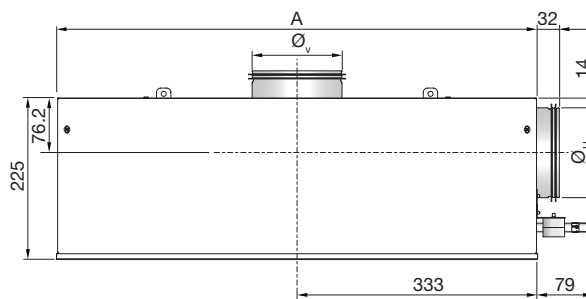
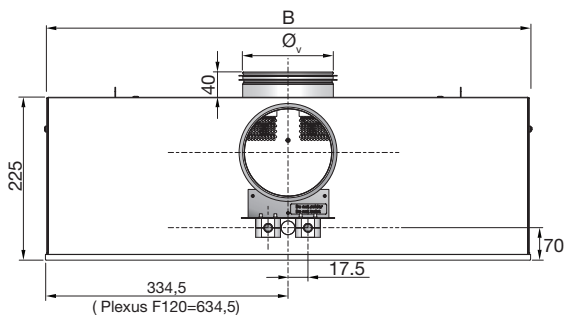

	A mm	B mm	\varnothing_H mm	\varnothing_v mm
F (S, L, M, H) 60	669	669	125	125/160
F S 120	669	1269	125	160

!	Plexus (F) - (S)	Plexus (F) - (L, M, H)
	=> $\varnothing_v = 125$	=> $\varnothing_v = 160$

Table 4. Dimensions [mm]

Picture 17. Plexus F dimensions.

Active chilled beam

Plexus

Dimensions, mm

Plexus 60: I, (X, Y, Z)

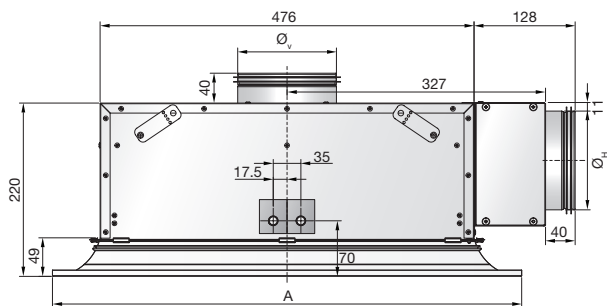

Picture 18. Plexus I-60 dimensions, cooling or heating, (standard).

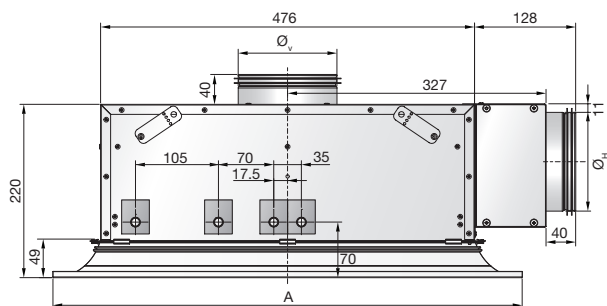

Picture 19. Plexus I-60 dimensions, cooling + heating.

Plexus 120: I, (X, Y, Z)

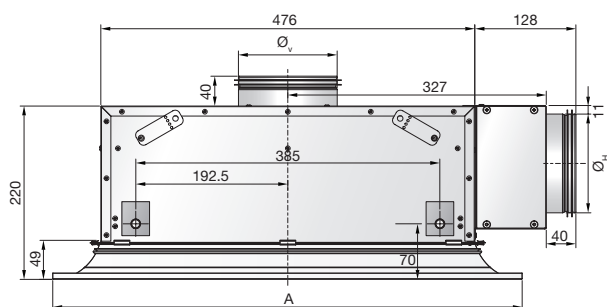

Picture 20. Plexus I-120 dimensions, cooling or heating, (standard).

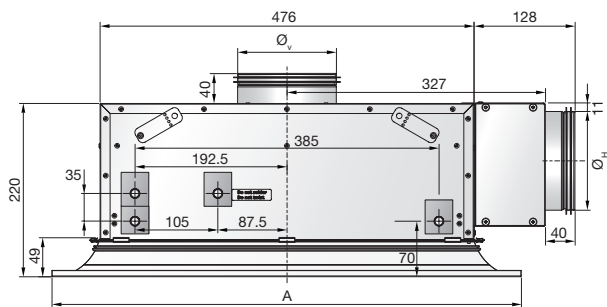

Picture 21. Plexus I-120 dimensions (cooling + heating).

Dimensions Plexus

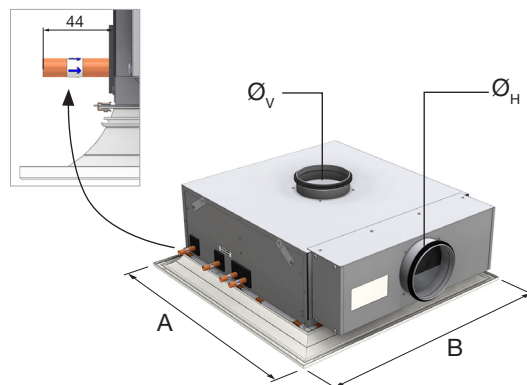

Picture 22. Plexus I-60.

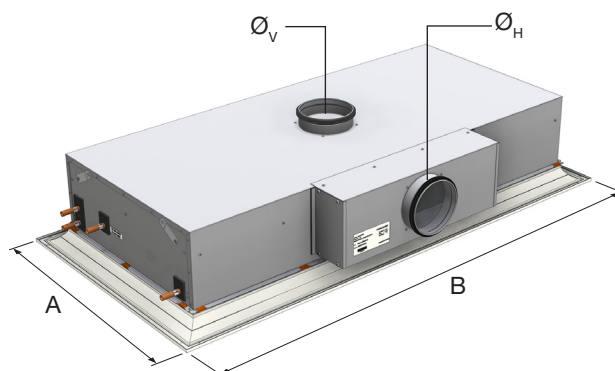

Picture 23. Plexus I-120.

Type	A	B	Ø _H	Ø _V
I (S/SA, L, M, H) 60	594	594	125	125/160
X (S, L, M, H) 60	599	599	125	125/160
Y (S, L, M, H) 60	575	575	125	125/160
Z (S, L, M, H) 60	584	584	125	125/160
F 60	669	669	125	125/160
I (S, L, M, H) 62	619	619	125	125/160
I (S, L, M, H) 67	669	669	125	125/160
I S/SA 120	594	1194	125	160
X S 120	599	1199	125	160
Y S 120	575	1174	125	160
Z S 120	584	1183	125	160
F 120	669	1269	125	160
I S 122	619	1244	125	160

Table 5. Dimensions [mm].

Plexus 60 in config. S/SA has Ø_V 125 and L/M/H Ø_V 160.

Active chilled beam

Plexus

LindQST - just a click away

The Lindab Quick Selection Tool, [LindQST®](#), is a very fast, easy-to-use and flexible online tool for your daily work.

[Calculate the Plexus here](#)



Picture 24. LindQST - Indoor Climate Designer

LindQST® helps you select the right waterborne products, e. g. active chilled beams, passive radiant chilled beams, radiant cooling- and heating panels and facade units and quickly finds the corresponding documentation.

In *Waterborne Documentation* you can easily find all available product documentation. Always in the latest version.

In *Waterborne Calculator* you can do a professional calculation based on your specific input data to finetune your choice or calculate different variants of the product. Smart warnings point out if a set-up will not work.

In *Waterborne Selector* you can compare the proposed products according to your specific requirements and select the one which fits best to your needs .

Not enough? With *Indoor Climate Designer* you can insert your selected waterborne product into your room and simulate the actual air distribution, optimize the placing in the ceiling taking into account the calculated air velocities and sound levels.

You can at anytime display your selection and calculations graphically. In addition, you can print or save all results and related documents for your documentation (incl. data sheets, dxf-files and room books).

With LindQST® you will easily find the most suitable product for your project.

It provides an easy and quick access to the latest product information, technical specifications and assembly instructions on the Internet, making it the ideal tool installers, consultants and architects alike.

www.LindQST.com

- Easy access to all current documentation.
- Fast design of waterborne products.
- Indoor Climate Designer: Graphical representation of the spatial situation in 2D / 3D and floor plans from AutoCAD®.
- Calculation of capacities, sound power levels, pressure losses and flow conditions.
- 3D particles or smoke show the air distribution in the room.
- Diagram showing the time course of the CO₂ concentration in the room.
- Room book generation and data sheet for individual rooms and outlets or entire projects.
- Project can be saved and exchanged in its own project area.
- Fast product selection waterborne products in accordance to Eurovent (chilled beams and facade units).



Active chilled beam

Plexus

Plexus & accessories

Lindab can offer a wide series of regulation possibilities with Lindab Regula. Regula Combi can be fitted into Plexus, or it can be used as an external regulator. With Regula Combi you are able to control and regulate both the heating and cooling valves within Plexus, this means that only one regulator can easily control the Indoor Climate in the room. With Regula Connect you can even control more than one unit in one regulator.

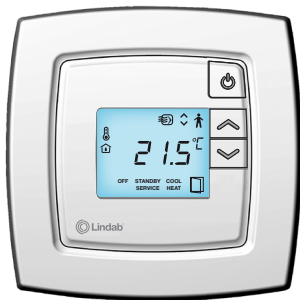

Regula Combi

Regula segura

This regulator offers you the possibility to ensure that condensation in Plexus does not occur.

Plexus & Lindab Safe Click

Plexus is equipped with Lindab Safe Click as a standard, which makes the usage of a screw or pop rivet unnecessary, and facilitates a fast installation of the units.



Variants

Water Connection: Standard Ø12 mm water connection.

Air Connection: Standard Ø125 mm horizontal connection or Ø125/160 mm vertical connection (see connections chapter).

Plus features

Valves and actuators: All models of Plexus can be delivered with valves and actuators. (Delivered loose with the product).

Connection Card: When using Regula Connect, the connection Card ensures fast and easy wiring between the units actuators.

Down fold battery: Requires connection with flex hose. Battery runs down about 20 cm at one end.

For further plus features see Plus features.

Order code

Product	Plexus	I	S	60	12	125	A5	60	20
Ceiling adaption:									
I = Integrated, lay-in									
X = i.e. hidden T-bar, edge DS									
Y = i.e. edge E T24									
Z = i.e. edge E T15									
F = Free hanging									
Configuration Air volume:									
S = Standard									
L = Low									
M = Medium									
H = High									
SA=Standard w. steel frame									
Size:									
60, 62, 67									
120, 122									
Water connection:									
12 mm									
Air connection:									
A: Ø125 mm, B: Ø160 mm									
Connection alternative:									
A5, A6, B5, B6 (Plexus F: A1, B1)									
Static nozzle pressure (Pa):									
Air volume (l/s):									



Most of us spend the majority of our time indoors. Indoor climate is crucial to how we feel, how productive we are and if we stay healthy.

We at Lindab have therefore made it our most important objective to contribute to an indoor climate that improves people's lives. We do this by developing energy-efficient ventilation solutions and durable building products. We also aim to contribute to a better climate for our planet by working in a way that is sustainable for both people and the environment.

[Lindab](#) | For a better climate