



# Lindab Pascal

## Wiring

Regula Master HTML  
Regula Combi version 1.5



# Table of content

# Pascal

## Table of content

**Page**

Overview of connections GRM.....	3
Overview of connections SRM.....	4
Overview of connections RM.....	5
Correct wiring.....	6
Cables.....	7
Wiring overview.....	8
Correct wiring with Regula Control Pascal .....	9
Correct wiring with RS485.....	10
Correct wiring with Connection cards.....	11
Correct wiring Single Regula Master (SRM).....	12
Correct wiring Global Regula Master (GRM).....	13
Correct wiring Accessories.....	14
Regula Combi (SRC).....	15
Connection ERC/EUC.....	16



# Overview of connections GRM Pascal

## Global Regula Master (GRM) / Local Regula Master (LRM)- TCP / IP

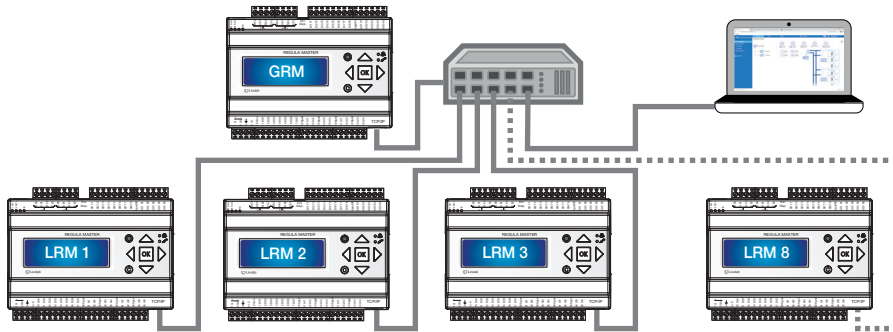

### TCP / IP

When communicating via BMS (Building Management System), the different Regula Masters are connected via their TCP/IP port with RJ45 cables through a router.

A GRM can be connected to max. 8 LRM's.

## Local Regula Master (LRM)

### Supply Regula Combi (SRC) / Extract Regula Combi (ERC) / Extract Ultralink Controller (EUC) - Exoline RS485- Exoline RS485

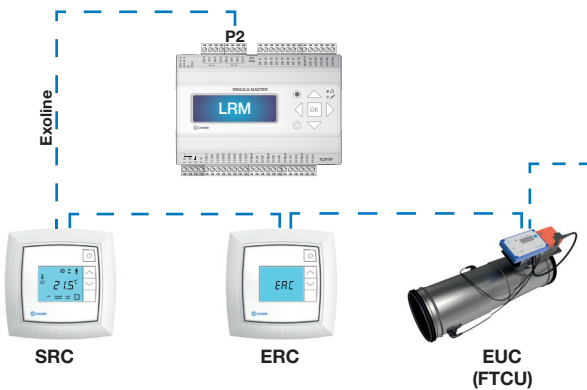

### Exoline RS485

LRM can from port 2 (P2) be "Daisy chain" connected to various Regula Combis via Exoline RS485 cables.

Port 2 (P2) is for Regula Combi, EUC and FTMU.

For correct wiring see page 5.

### General notes

- Max 26 SRC, 16 ERC/EUC and 8 FTMU on a Regula Master (LRM).
- EUC dos NOT require a Regula Combi in front.
- Do NOT mix G0- and G+ !

## Connection with Regula Connect Pascal

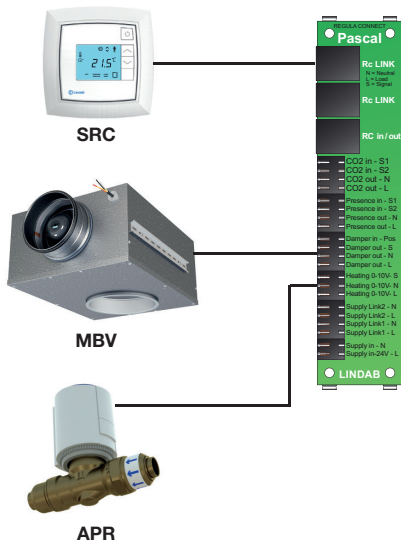

## Connection with Regula Control Pascal

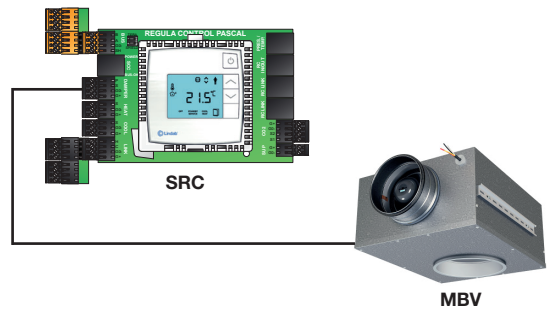

## Connection without card



# Overview of connections SRM Pascal

## Single Regula Master(SRM) / Local Regula Master (LRM) - TCP / IP

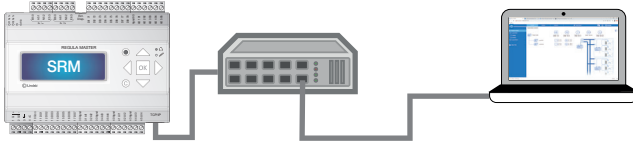

### TCP / IP

When communicating via BMS (Building Management System), the Regula Master is connected via their TCP/IP port with RJ45 cables through a router.

When using SRM there is only one Regula Master.

## Single Regula Master (SRM) - Supply Regula Combi (SRC) / Extract Regula Combi (ERC) / Extract Ultralink Controller (EUC) - Exoline RS485- Exoline RS485

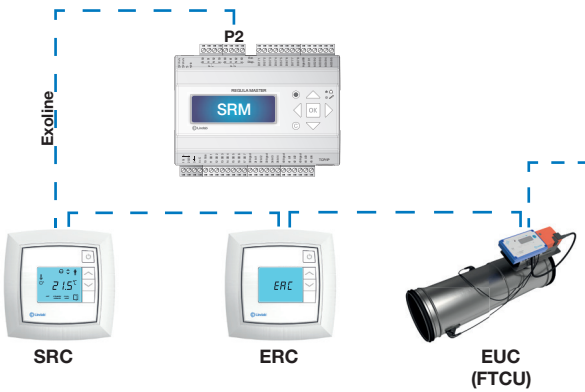

### Exoline RS485

SRM masters can from port 2 (P2) be "Daisy chain" connected to various Regula Combis via Exoline RS485 cables.

Port 2 (P2) is for Regula Combi, EUC and FTMU.

For correct wiring see page 5.

### General notes

- Max 26 SRC, 16 ERC/EUC and 8 FTMU on a Regula Master (SRM).
- EUC dos NOT require a Regula Combi in front.
- Do NOT mix G0- and G+ !

## Connection with Regula Connect Pascal

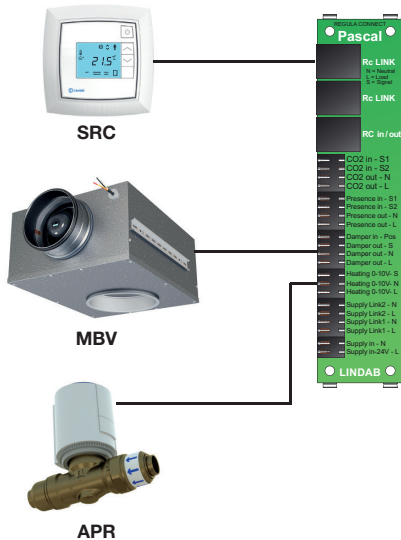

## Connection with Regula Control Pascal

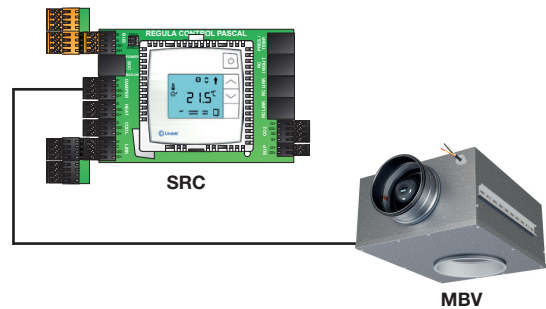

## Connection without card



# Overview of connections RM Pascal

## Connection supply - component selection

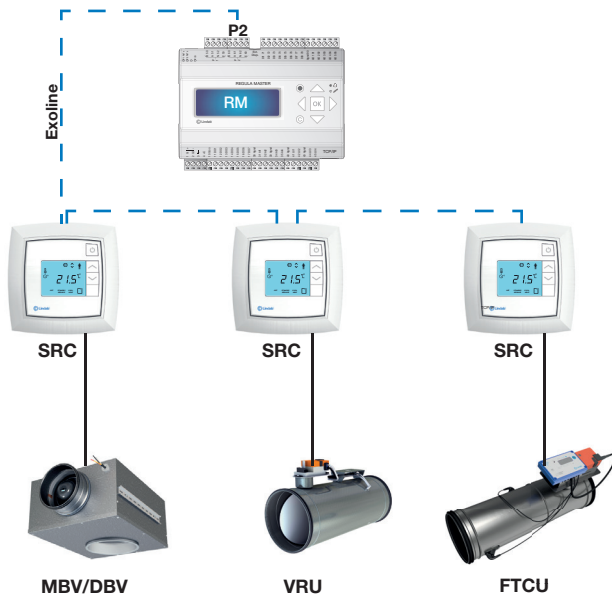

### Exoline RS485

SRM/LRM masters can from port 2 (P2) be "Daisy chain" connected to various Regula Combis via Exoline RS485 cables.

Port 2 (P2) is for SRC.

For correct wiring see page 5.

### General notes

- Max 26 SRC on a Regula Master (SRM/LRM).
- Every SRC can control upto 10 dampers of same type and size.
- Do NOT mix G0- and G+ !
- Supply and Extract is on the same Exoline connection.

## Connection Extract - component selection

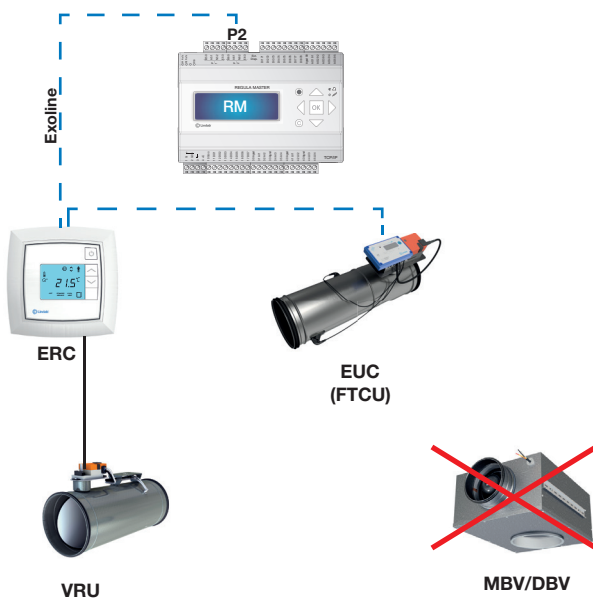

### Exoline RS485

SRM/LRM masters can from port 2 (P2) be "Daisy chain" connected to various Regula Combis and EUC's via Exoline RS485 cables.

Port 2 (P2) is for ERC, EUC and FTMU.

For correct wiring see page 5.

### General notes

- Max 16 ERC or EUC on a Regula Master (SRM/LRM).
- Both ERC and EUC can be used in same system.
- EUC dos NOT require a Regula Combi in front. The FTCU is connected directly to LRM/SRM.
- MBV/DBV can NOT be used for extract.
- Do NOT mix G0- and G+ !
- Supply and Extract is on the same Exoline connection.

# Correct wiring

# Pascal

## LRM/SRM - SRC/ERC

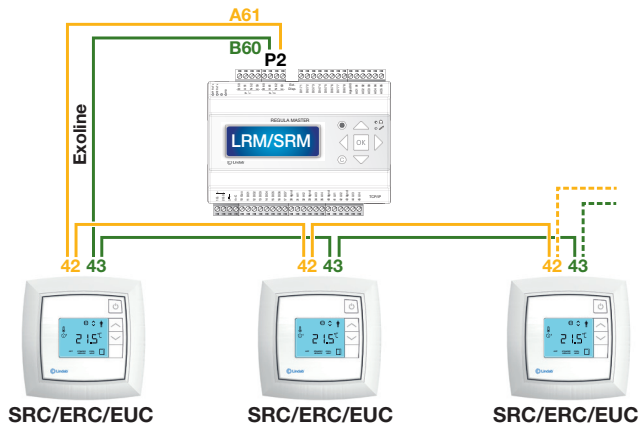

Do not mix A and B. Always use Daisychain connection.

## LRM/SRM - Reg. Con. Pascal - SRC/ERC

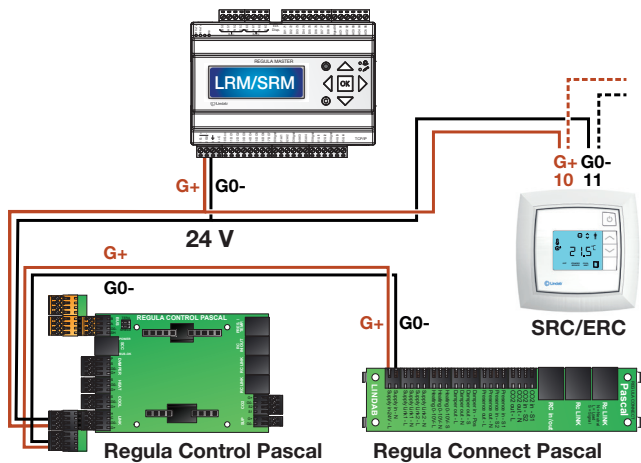

Both star- and chain connection can be used for 24 V power supply.  
Do not mix G0- and G+!

## LRM/SRM - SRC/ERC - **Star connection**

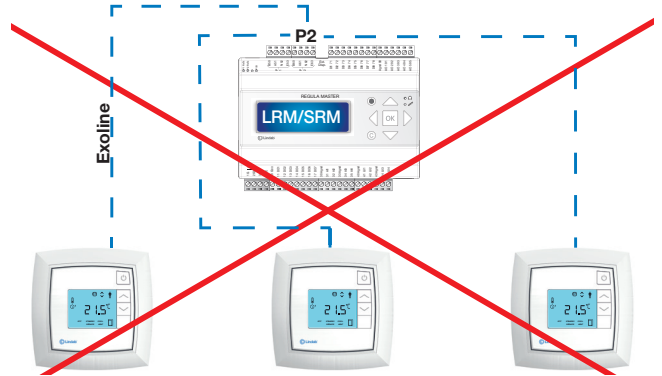

## LRM/SRM - Reg. Con. Pascal - SRC/ERC

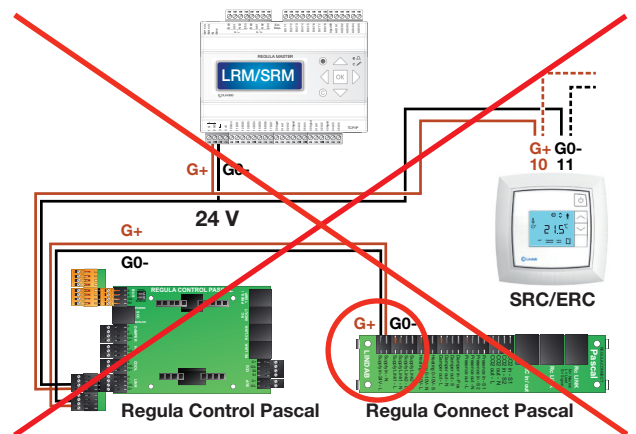

Do not mix G0- and G+!

# Cables

# Pascal

## Transformer sizing

The needed size of 24 V AC transformer(s) can be defined by adding up the dimensioning power consumption [VA] of all the components. The transformer power must exceed this. Use only safety isolating transformers. Calculation of the current demand I:

$$I = (P_1 + P_2 + \dots + P_n) / U \text{ [A]}$$

where:

$P_n$  is the dimensioned power consumption for each component [VA].

U is the voltage (24) [V]

If the current demand I exceeds 6 A ( which corresponds to approximately 150 VA for a 24 V AC transformer ), it is necessary to use more transformers to prevent overheating of Regula Control/Connect Pascal and avoid the need for very thick supply cables.

## Supply cable sizing

The wire size of the supply cable can be determined by calculating the resistance per meter R. The calculation presupposes that a voltage drop of e.g. 2 V is accepted in the supply cable:

$$R(\text{per m}) = U_{\text{drop}} / (I \times L) \text{ [\Omega/m]}$$

where:

$U_{\text{drop}}$  is the accepted voltage drop (2 V) in the cable [V].

I is the current [A].

L is the longest distance of supply cables from transformer to a component [m].

## Power consumption

The power consumption for dimensioning supply cables can be read in the table below.

Components	Power consumption [VA]
DBV/MBV	4.5 VA
VRU-MF ( 100-315 )	4 VA
VRU-MF ( 400-630 )	5 VA
Regula Combi	2.5 VA
Regula Master	5 VA
Presence sensor	3 VA
CTDT2	1 VA
CO2RT-R-LB	3 VA
CTRTA(-D)-LB / CTRT2(-D)	5 VA
Regula Pulse	1 VA
FTCU 100 - 315	3 VA
FTCU 400 - 630	5 VA
FTMU	0.5 VA
APR 40405	6 VA

### Example:

$$U_{\text{drop}} = 2 \text{ V}, I = 4 \text{ A}, \quad L = 20 \text{ m}$$

$$R(\text{per m}) = 2\text{V} / (4\text{A} \times 20\text{m}) = \mathbf{0,025 \Omega/m}$$

In the diagram a Wire cross section Area of 0.7 mm<sup>2</sup> can be read.

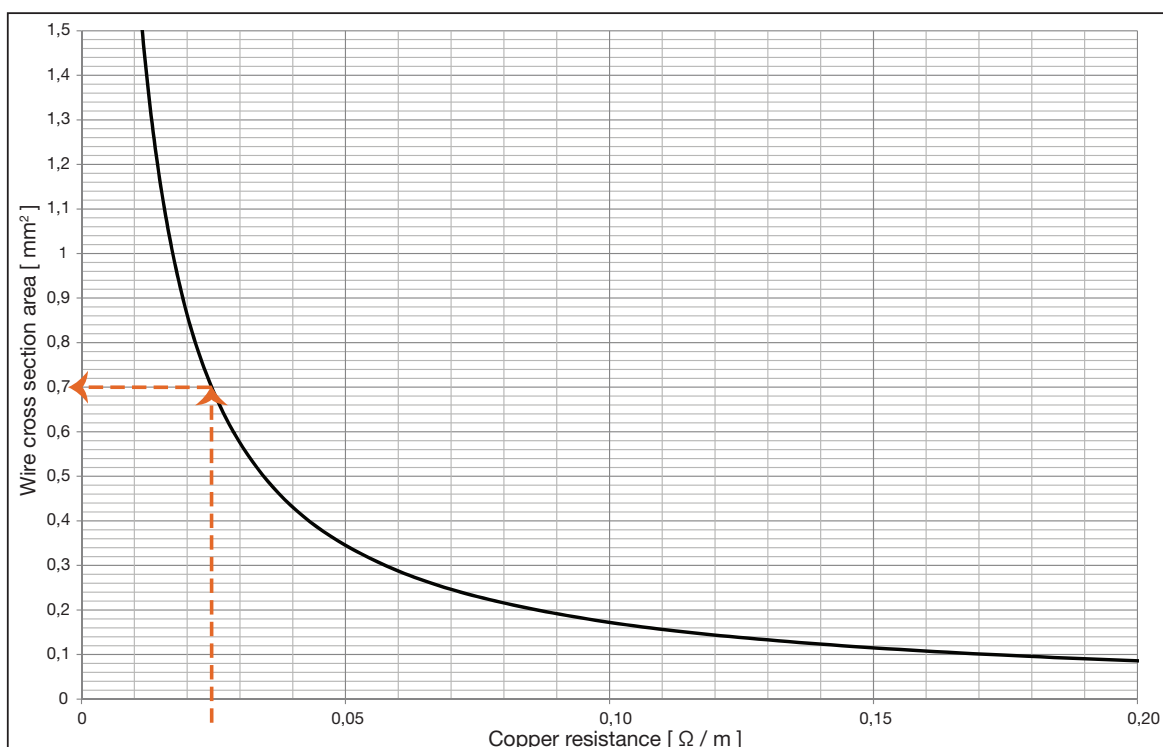

# Wiring overview

# Pascal

## Wiring Pascal components

Recommendation for wiring the Pascal system.

Cables for Pascal components		
Function	Pascal components	Cable type
EXOline	Regula Master / Regula Combi	2-wire shielded twisted pair, min. 0.1 mm <sup>2</sup> Recommended 0.22 mm <sup>2</sup> LIYCY cable
TCP	Router / Switch / Regula Master	Patch cables straight through, RJ45
Signals	Regula Con. (Link) / Regula Combi	Patch cables straight through, RJ45 terminated T568B
Diffuser integrated Presence/ Temperature	Regula Con. / Sensor	Patch cables straight through, RJ45 terminated T568B (cable included in diffusers Lxx-P)

Cables for Pascal components		
Function	Pascal components	Cable type
Heating/ Cooling 0-10 V	Regula Con. / APR 40405	3-wire min 0.22 mm <sup>2</sup> , max 1.5 mm <sup>2</sup>
CO <sub>2</sub> / RH% sensors	Regula Con./ Sensor	4-wire min. 0.1 mm <sup>2</sup> , max 1.5 mm <sup>2</sup>
Als and AOs on RM	Regula Master / Sensors / Relays / AHU Control	2/3/4-wire min 0.22 mm <sup>2</sup> , max 1.5 mm <sup>2</sup>
24 V Supply	Transformer/ Regula Con. (Link)	2-wire thickness depending on length and load, max 1.5 mm <sup>2</sup>

## Connecting actuators

The maximum number of actuators that can be connected to the digital output (ON/OFF) is 10 for cooling and heating, respectively. When more than 4 on/off actuators for cooling or heating are connected, terminal blocks 10 and 20 must be connected with a cable because the Regula Combi print card can not handle the output power for more than 4 on/off actuators.



# Correct wiring

# Pascal

## LRM/SRM - SRC/ERC with Regula Control Pascal

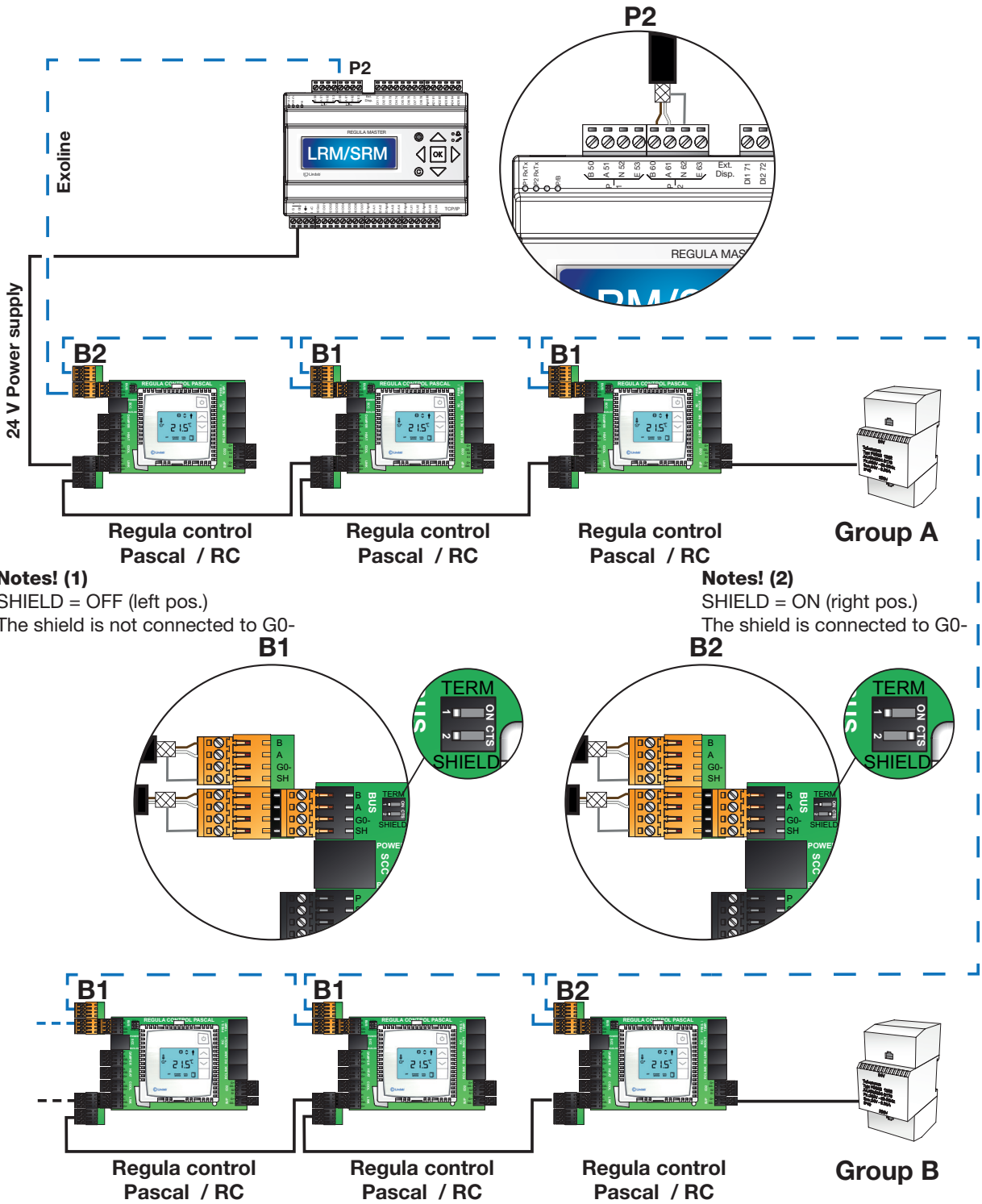

### Jumper J1/J2

J1 TERM: Terminators of RJ45 bus for Exoline is rarely needed. It should be in position OFF. In rare cases with com issues, only set the last unit on the line to ON.

J2 SHIELD: Connection of shield to G0-. If Regula Master is in same transformer group, let it stay in OFF. Shield should only be grounded in one point.

# Correct wiring

# Pascal

## RS485

The shielded twisted pair cable have two cables and one shield. The two cables should be connected on plinth 42 and 43 (1) on each Regula combi. The shield should be connected on plinth 41(2) in the last Regula Combi in each trafo group, to the other Regula combis the shield should be twisted with next shield.

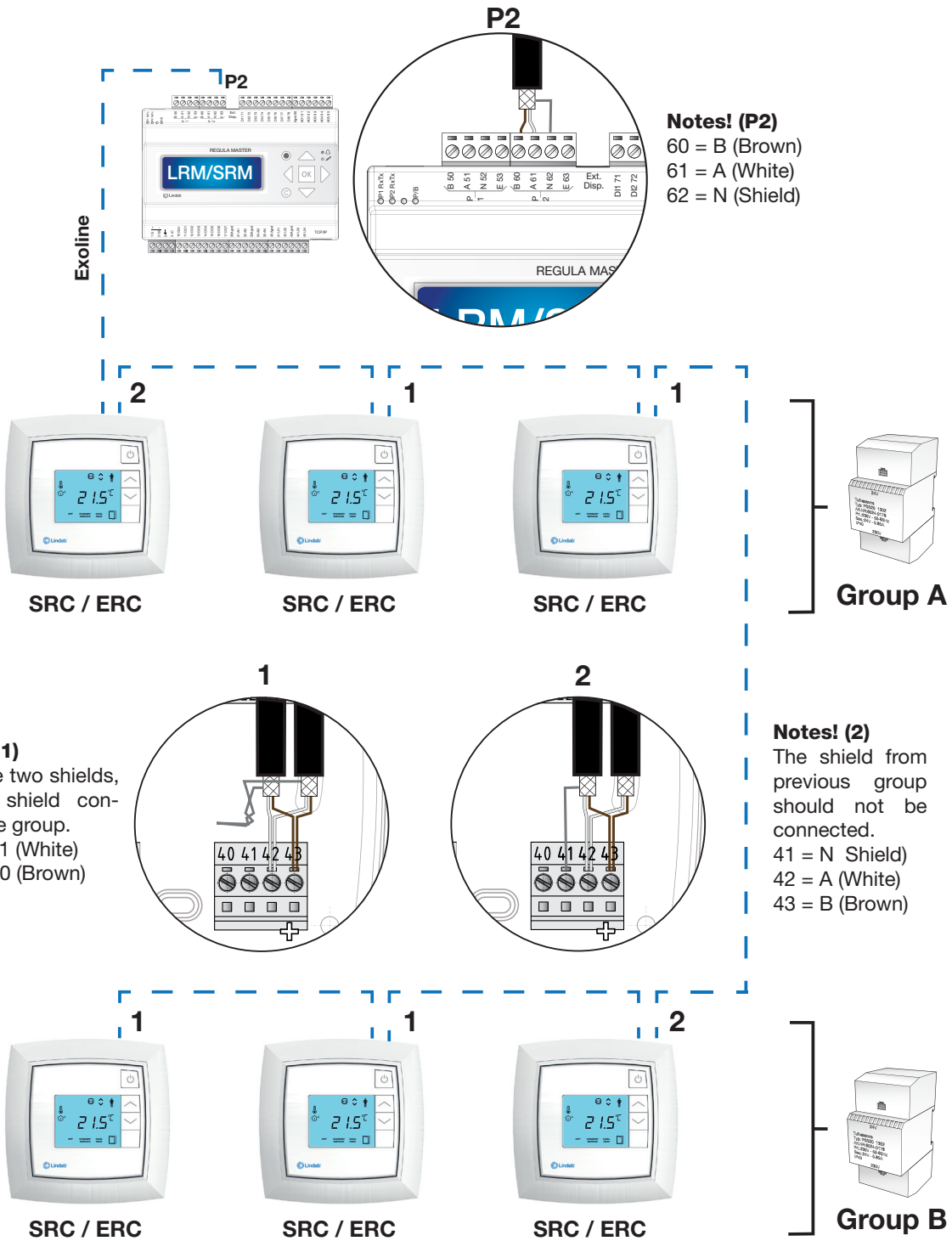

# Correct wiring

# Pascal

## SRC/ERC and connection cards.

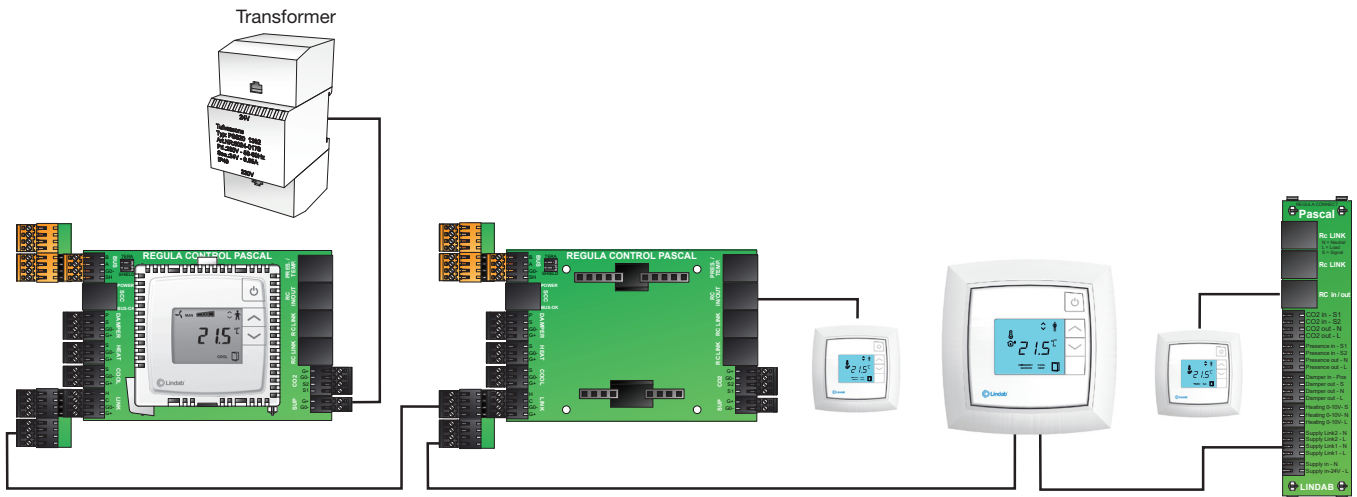

## Power supply connections when one SRC controls several dampers.

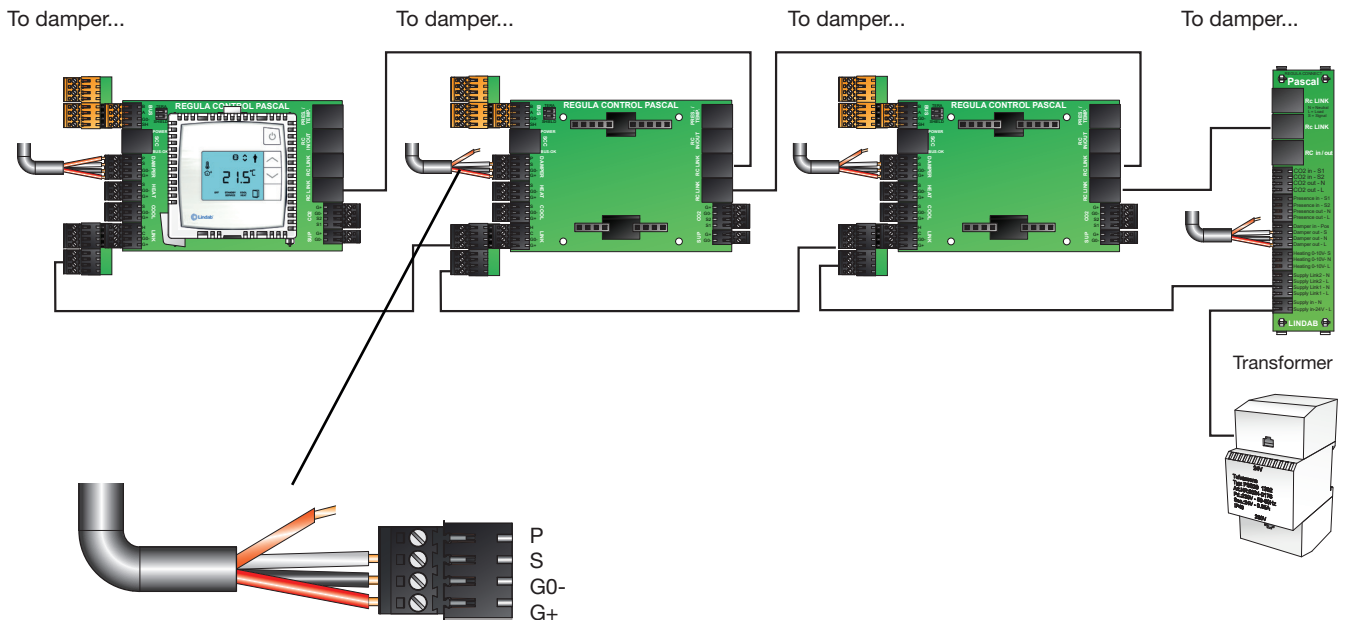

If a Regula Combi is controlling more VAV-dampers via RC link on Regula Connect/Control Pascal, only ONE damper position signal, (5. Orange -from VAV-damper/Belimo motor), must be connected.

# Single Regula Master

# Pascal

## SRM/SRC/ERC

Fan optimizer function is ideally to varying the fan pressure between a min and max setting in AHU. Do not flow regulate the fans!

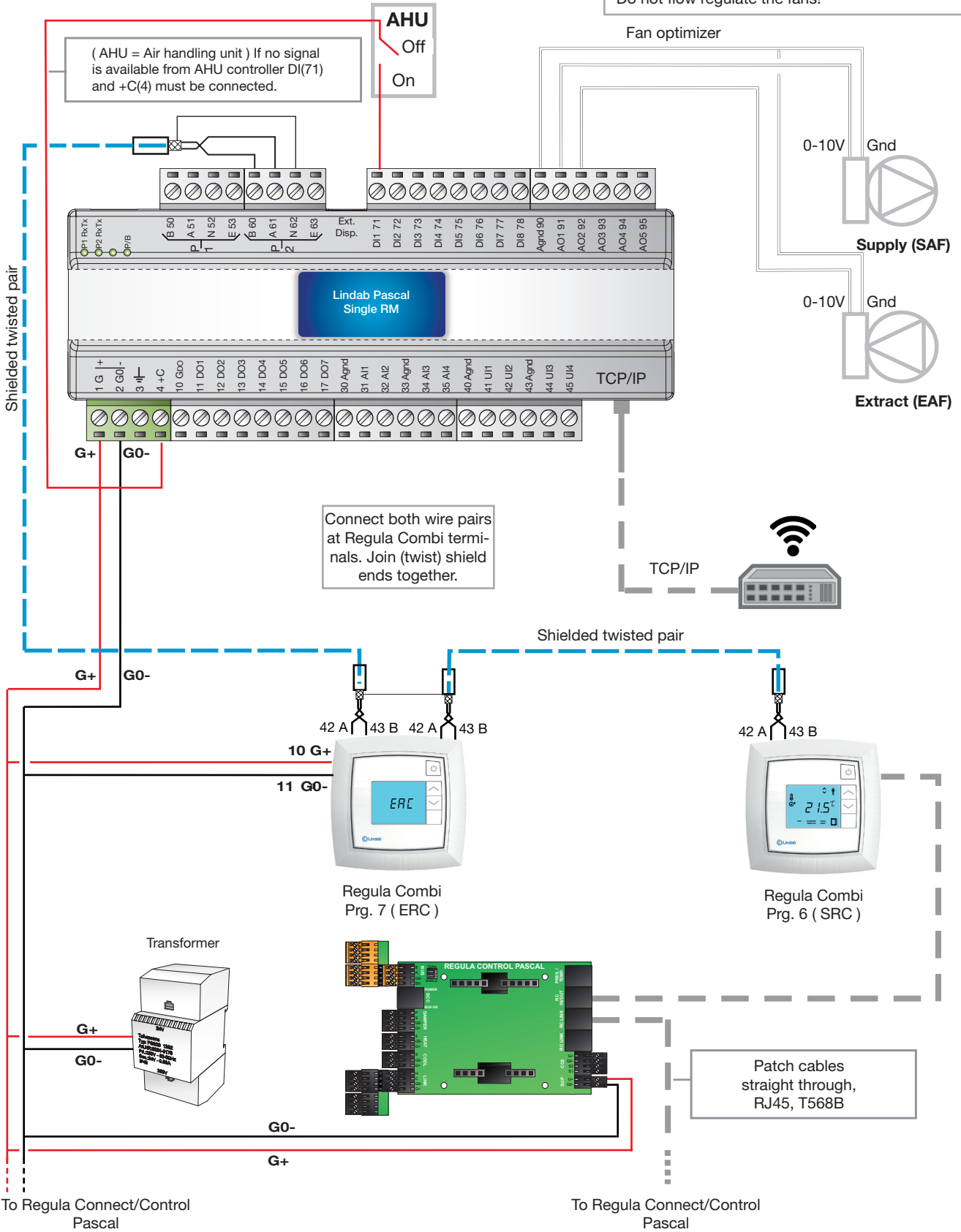



# Global Regula Master

# Pascal

GRM/LRM/SRC/ERC

Fan optimizer function is ideally to varying the fan pressure between a min and max setting in AHU. Do not flow regulate the fans!

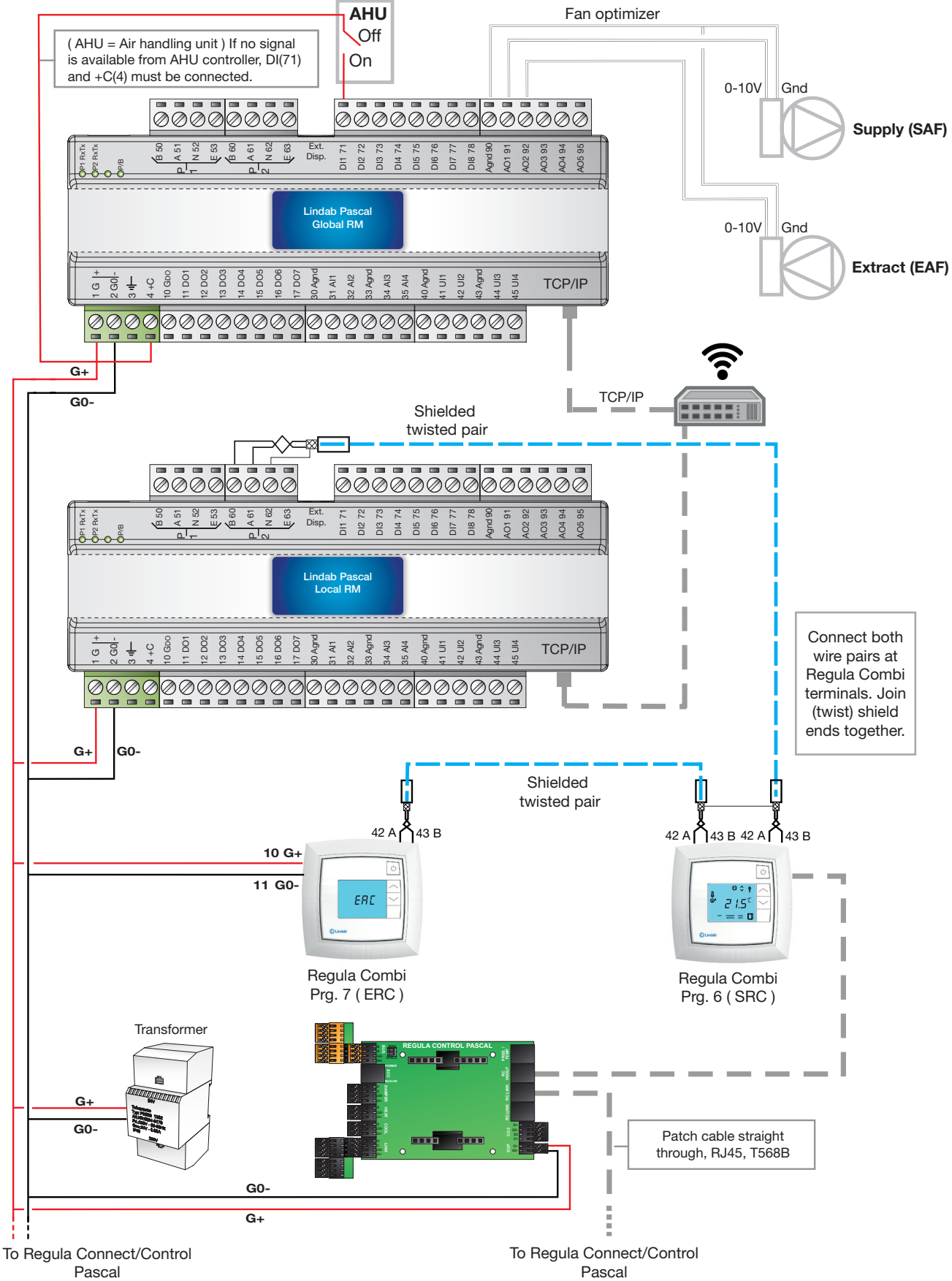

# Global/Single Regula Master

# Pascal

## Accessories and additional functions (optional)

Fan optimizer function is ideally to varying the fan pressure between a min and max setting in AHU.  
Do not flow regulate the fans!

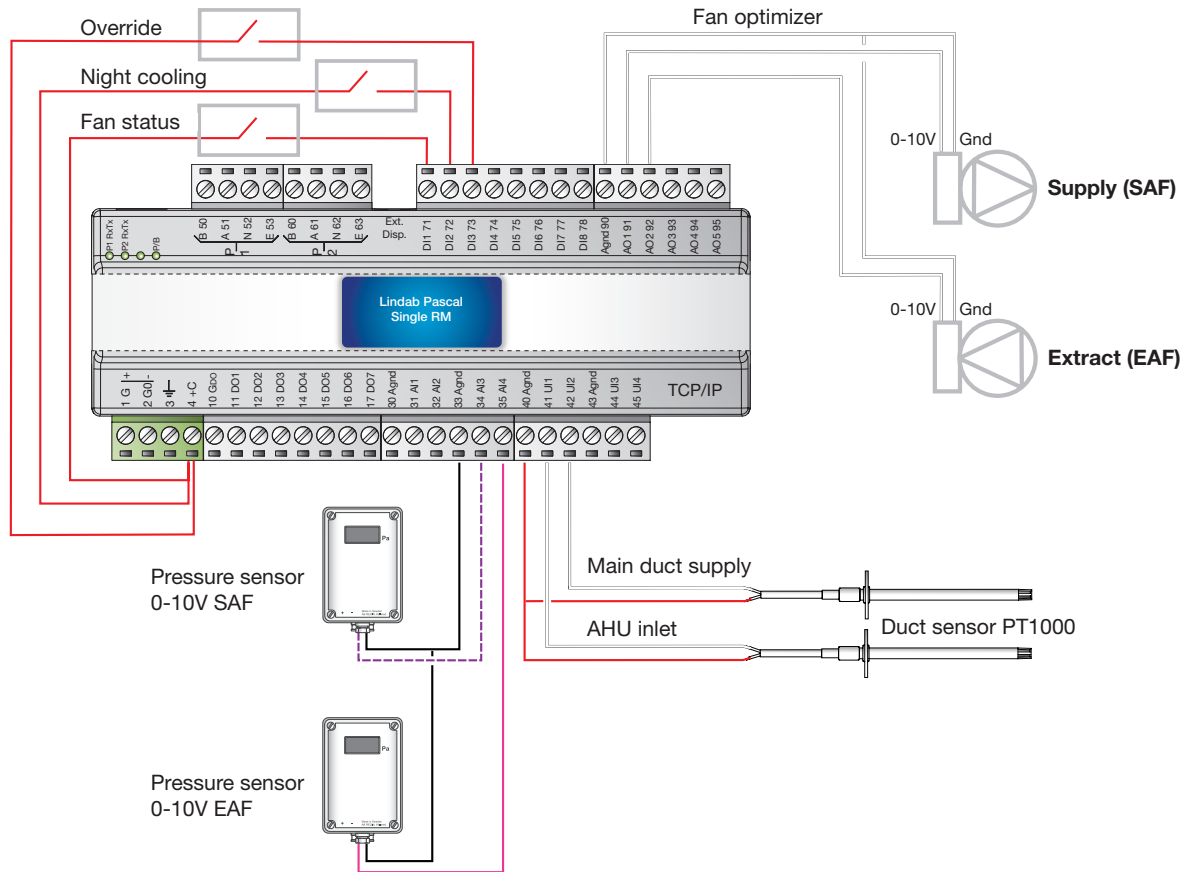

### Accessories

#### Duct temperature sensors

- ACB free cooling optimizer (both sensors).
- Outdoor air cooling (Main duct supply).

#### Pressure sensors

- Pressure limitation (if AHU is not limiting the pressure).

### Additional functions

Override control mode, DI3 73 - 4+C

Night cooling, DI2 72 - 4+C

Fan status, DI1 71 - 4+C

Fan optimizer Agnd 90, AO1 91, AO2 92

# Regula Combi

# Pascal

## Important notes !

### Connecting SRC to Regula Connect/Control Pascal card

For easy connection, use the Regula Combi Pascal adapter.

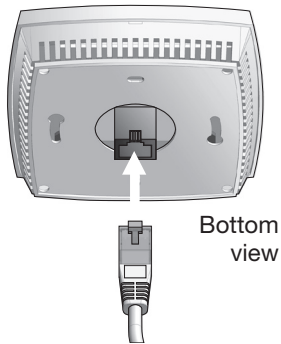

**Note!** When wall-mounting a patch cable with a bend head will often be easier to fit.

Use minimum a 14 mm electrical Conduit Pipe to fit patch cable through.

### Connecting VAV-damper signals to Regula Connect/Control Pascal card

Max 10 Regula Connect/Control Pascal (VAV dampers) linked to a Regula Combi.

If a Regula Combi is controlling more VAV-dampers via RC link on Regula Connect/Control Pascal, only ONE damper position signal, (5. Orange -from VAV-damper/Belimo motor), must be connected.

Select the damper position signal from the VAV damper with least pressure. Damper position signals from the other VAV-dampers MUST be disconnected from the terminal on the Regula Connect/Control Pascal.

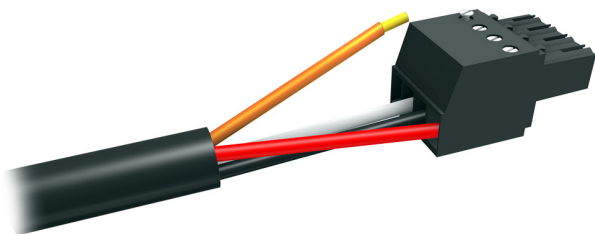

Figure 1. Cable from VAV-damper/Belimo motor where wire 5, orange, is disconnected.

## Colours

1. Black
2. Red
3. White
5. Orange

## Connecting with patch cable

If connecting the patch cable wires directly to the Regula Combi terminals, CLARIFY IF YOU HAVE THE "A" or "B" CABLE VERSION !

**!** Patch cables straight through, RJ45, T568B

### T568B :

Combi	RJ45 pins
23	1 White/Orange
24	2 Orange
31	3 White/Green
32	4 Blue
40	5 White/Blue
33	6 Green
10	7 White/Brown
11	8 Brown

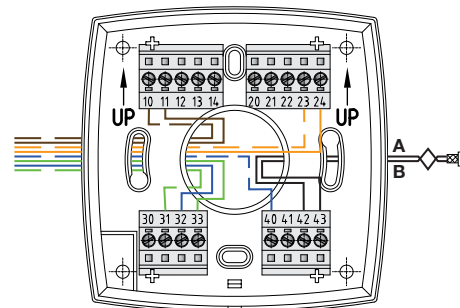

### T568A :

Combi	RJ45 pins
23	1 White/Green
24	2 Green
31	3 White/Orange
32	4 Blue
40	5 White/Blue
33	6 Orange
10	7 White/Brown
11	8 Brown

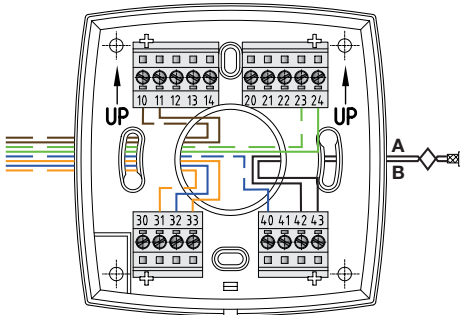

RJ45 Pinout T-568A

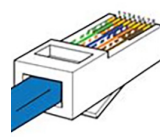

RJ45 Pinout T-568B

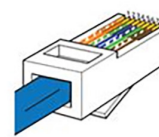

1. White/Green
2. Green
3. White/Orange
4. Blue
5. White/Blue
6. Orange
7. White/Brown
8. Brown

1. White/Orange
2. Orange
3. White/Green
4. Blue
5. White/Blue
6. Green
7. White/Brown
8. Brown

# Regula Combi

# Pascal

## Connecting ERC

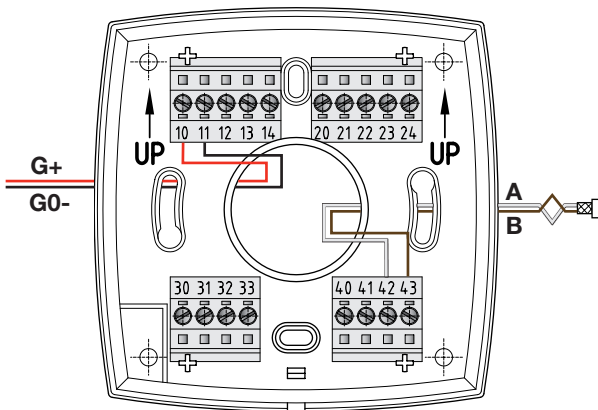

Avoid that the shield cable touches the mountingplate or other metal parts.

## Connecting EUC

For wiring with premounted cable:

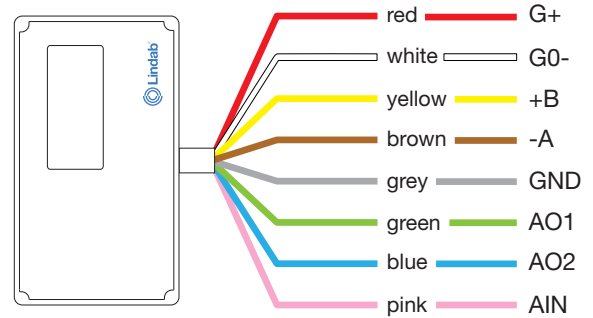

- Red** G+, 24V, power supply\*
- White** G0-, GND, power supply\*
- Yellow** +B, connection for Exoline via RS485
- Brown** -A, connection for Exoline via RS485
- Grey** GND, ground (system neutral)\*\*
- Green** AO1, analog output\*\*
- Blue** AO2, analog output
- Pink** AIN, analog input

\*) When using AC terminal 1 (G+) should have system potential and terminal 2 (G0-) should be system neutral.

\*\*) Not used for Pascal





Most of us spend the majority of our time indoors. Indoor climate is crucial to how we feel, how productive we are and if we stay healthy.

We at Lindab have therefore made it our most important objective to contribute to an indoor climate that improves people's lives. We do this by developing energy-efficient ventilation solutions and durable building products. We also aim to contribute to a better climate for our planet by working in a way that is sustainable for both people and the environment.

[Lindab](#) | For a better climate