

Lindab **Munio**

Active chilled beam

Installation instructions



1. Content and symbols

1. Content and symbols.....	2
1.1 Content.....	2
1.2 Symbols.....	3
2. Control of delivery	3
2.1 Safe operation.....	3
2.2 Handling.....	3
2.3 Receipt of goods.....	3
2.4 Unloading of goods.....	3
2.5 Handling / Carrying.....	3
2.6 Tools.....	4
2.7 Installation.....	4
2.8 Where to find installation instruction.....	4
2.9 Cleaning after assembly/before commissioning.....	4
2.10 Packing, unpacking guideline.....	5
2.11 Product labelling.....	6
2.12 Order code.....	7
2.13 Order code example.....	7
2.14 Label.....	7
2.15 Contents of order.....	8
2.16 Plus features.....	8
2.16.1 Inlet faceplates.....	8
2.16.2 Outlet front grilles (separate order and package).....	8
2.16.3 Integrated valves.....	8
2.16.4 Integrated Actuators.....	8
2.16.5 Integrated Regula components.....	8
2.17 Accessories.....	8
3. Product specification.....	9
3.1 Product description.....	9
3.2 Dimension.....	9
3.3 Munio.....	9
3.4 Material data.....	10
3.5 Environmental Declarations.....	10
3.6 Pressure class.....	10
3.7 Water quality.....	10
3.8 Air quality.....	10
3.9 Capacity test.....	10
4. Connections.....	11
4.1 Water connections.....	11
4.1.1 Before installation.....	11
4.1.2 Push on fitting.....	12
4.1.3 Compression fitting.....	12
4.1.4 Flexible hoses.....	13
4.1.5 Possible connections water cooling (2-pipe).....	13
4.1.6 Possible connections water cooling and heating (4-pipe).....	13
4.2. Air connections.....	14
4.2.1 Air connection installation.....	14
4.2.2 Possible connections supply air.....	14
4.2.3 Possible connections exhaust air.....	14
4.3 Possible combination of connections.....	14
4.4 Electrical connections.....	15

4.4.1 Regula components on the beam.....	15
4.4.2 Example 1: Wiring scheme with Regula Connect multi.....	16
4.4.3 Example 2: Wiring scheme with Regula Connect basic.....	16
4.4.4 Regula Connect on the beam.....	17
4.4.5 Regula Secura on the beam.....	17
4.4.6 Valves and Actuators on the beam.....	17
4.4.7 Regula Combi on/with the beam.....	17
4.4.8 Actuators.....	17
5. Installation of product.....	18
5.1 Handling of product.....	18
5.2 Adaption to ceiling systems.....	18
5.2.1 Ceiling systems.....	18
5.3 General installation principles.....	19
5.3.1 Recessed in suspended T-bar ceiling.....	19
5.3.2 Exposed, sealed to the ceiling.....	19
5.3.3 Exposed, free hanging.....	19
5.3.4 Free hanging above perforated or egg-crate ceiling.....	19
5.3.5 Recessed in suspended (permanent) ceiling with cover flanges.....	19
5.3.6 Recessed in suspended (permanent) ceiling without cover flanges.....	19
5.4 Preparation for installation on the product.....	20
5.5 Preparation for installations of the product.....	21
5.5.1 Cutout dimensions in the bulkhead.....	21
5.5.2 Basics steps of installing the product.....	22
6. Adjustment and commissioning.....	29
6.1 Airflow and pressure.....	29
6.1.1 Jet cone 2 adjustment points.....	29
6.1.2 Finding values for JetCone pins.....	30
6.1.3 Adjusting air flow and pressure with JetCone pins.....	30
6.2 Adjustment of air distribution profile.....	31
6.2.1 Adjustment of outlet grille vertical directional bars.....	31
6.2.2 Adjustment of outlet grille horizontal directional bars.....	31
6.3 Measuring air pressure and calculating the air flow.....	32
6.3.1 Measuring static nozzle pressure and air pressure.....	32
6.3.2 Calculating the actual air flow.....	32
6.3.3 Changing the actual air flow.....	32
6.3.4 Changing the air distribution profile.....	32
6.3.5 Munio pressure / airflow diagrams.....	33
6.4 Water flow rate.....	34
6.4.1 Pre-setting of valves.....	34
6.4.2 Balancing strategy.....	34
7. Maintenance.....	34
7.1 Remove the outlet front grille.....	34
7.2 Open inlet faceplate.....	34
7.3 Opening inspection hatch.....	35
8. Accessories.....	36

Installation instruction

Munio

1.2 Symbols

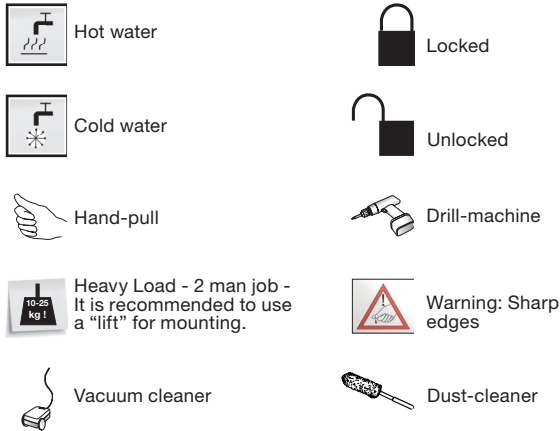

2. Control of delivery

2.1 Before you start

Read through the entire installation instruction before commencing installation in order to determine which parts that needs to be performed and in what order to be done.

Lindab is a supplier of complete water products, but we offer also a wide range of accessories which suits perfect to our water products and simplifying your installation work, e.g. different type of hanger, Tektite-couplings, closing valves, thermostatic valves and actuators, flexible hoses, customized regulation components, customized caballing and more. See also separate document "[Accessories](#)".

Lindab will also provide you with a full ventilation system, with a wide range of Lindab Safe components. See also "Air Duct Systems".

2.2 Safe operation

Beware of sharp edges, especially of the coils. Always wear thin gloves and protective clothing.

All existing safety regulations must be observed when working with Lindab water products. Check the weights of the beams or the panels with the installation instruction before carrying.

2.3 Receipt of goods

Start by checking that the delivery is complete according to the order and that everything listed on the consignment note has been delivered. Then carry out a review of the products and make sure that nothing was damaged during transportation. If you discover damage that has occurred during delivery, it must be notified immediately.

Lindab is not responsible for costs associated with the replacement of products, that have been installed in any other way, than shown in the installation instructions.

2.4 Unloading of goods

The beams and panels are normally delivered packed on wooden pallets. Lift the pallets carefully with a fork lift and place them on a dry and plain surface/ground. If the beams are delivered in single boxes, wooden blocks should be placed on the ground at one-metre intervals (or a pallet), before the boxes are been placed to store. Lindabs water products must be stored on a plane surface in a dry and well ventilated place, preferably indoors. If they have to be stored outdoors, protect them with a waterproof cover and store them protected from rain beneath a roof or other until they are fitted.

2.5 Handling / Carrying

The beam or panel must be handled with care, ensuring that it will not be scratched or bended during transportation, preparation and installation.



Never use piping connections or edges to lift them, neither when you unpack them nor when you carry them towards the construction site.

Do not place the product directly on the floor. Use the protective corners from package or other clean means from package to place the product before installation.

Be careful if you must carry a long panel horizontally; if the panels are bended lengthwise, the profiles may be deformed and the piping could be loosen from the panel. When opening the box with a knife, be careful not to damage the product.

Each beam is equipped with protective film to avoid any damage during transportation and handling on building site. The film needs to be removed before commissioning the products.

Installation instruction

Munio

2.6 Tools

To install the beam, panel or facade unit, the following tools are required.

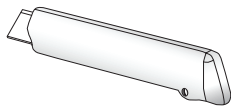

Knife



Gloves



Shoes with soft soles

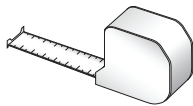

Tape measure

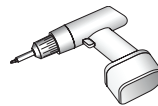

Drill machine

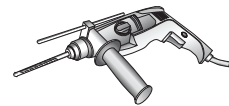

Percussion drill

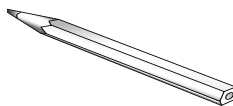

Pencil



Spanner

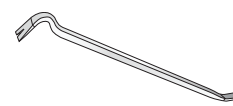

Crowbar

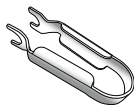

Tectite tool 12 mm
(Order no : 884087)



Tectite tool small 12 mm
(Order no : 646881)

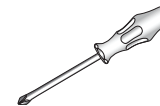

Screwdriver

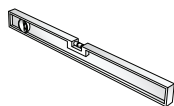

Spirit level

2.7 Installation

It is important to use the correct hangers and the recommended amount for all installation principles. Different possible installation principles are shown in the installation instruction and hangers from Lindab should be used to ensure, that they are intended for the purpose and are safe to use.

Lindab's water products can be ordered, to be adapted to a wide range of different ceiling systems, please check installation instruction to ensure best adaptation.

The Lindab water products should always be installed separately hanged up from the recessed ceiling. The weight of the product should not be covered by the ceiling system.

Use plastic folio or other to protect the product during on site construction continually to keep the products in best condition and avoid any scratches.

2.8 Where to find installation instruction

Installation instruction can be found outside pallet. If you need additional installation instruction:

1. Visit www.lindQST.com
2. Select "documentation finder"
3. Select "product name"
4. Select "installation instruction" in "related documents"
5. Or follow the barcode link on the right

2.9 Cleaning after assembly/ before commissioning

Please remember to remove plastic folio and other protection material before commissioning and clean the product before hand over.

Installation instruction

Munio

2.10 Packing, unpacking guideline

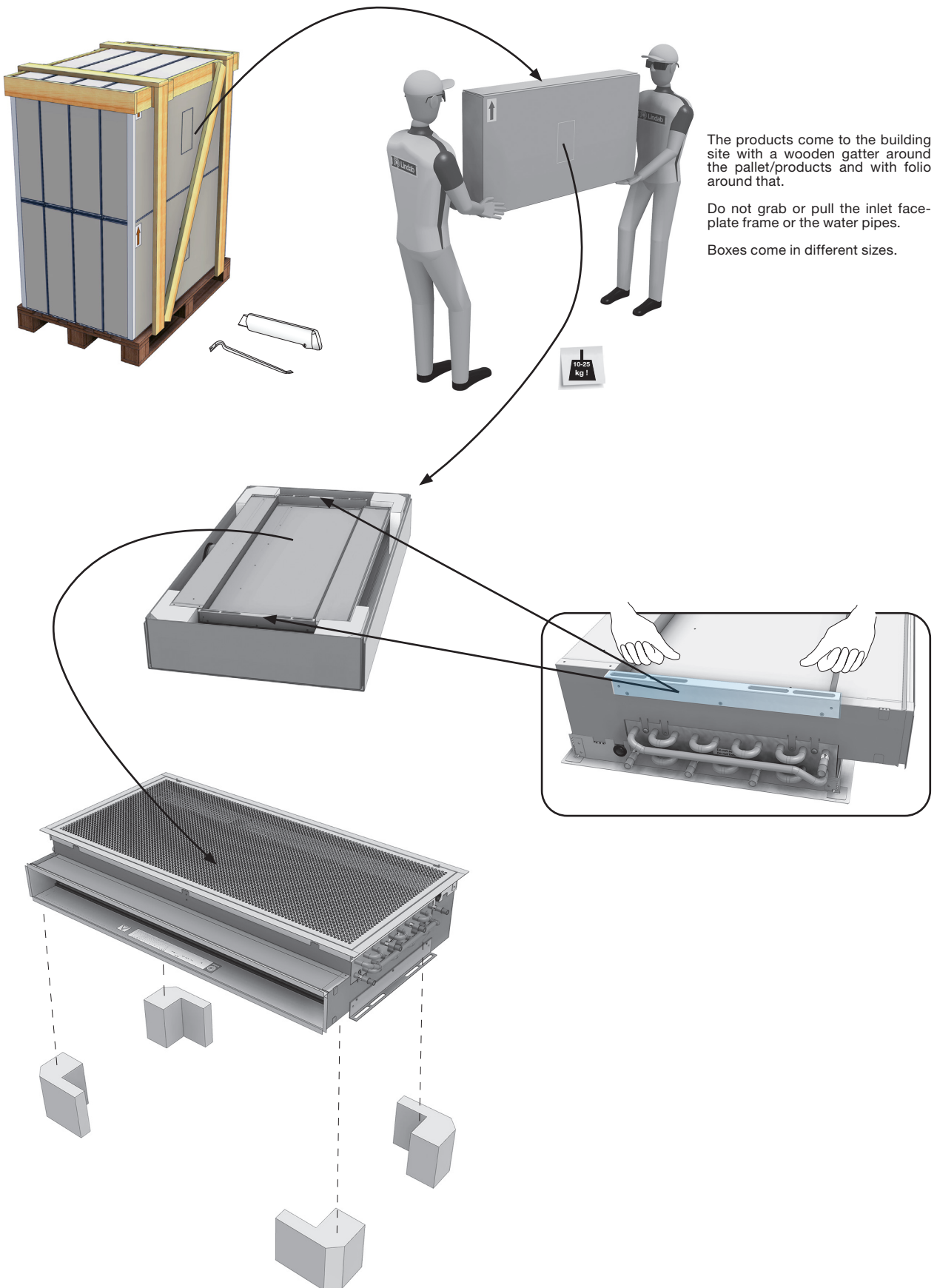



Installation instruction

Munio

2.11 Product labelling

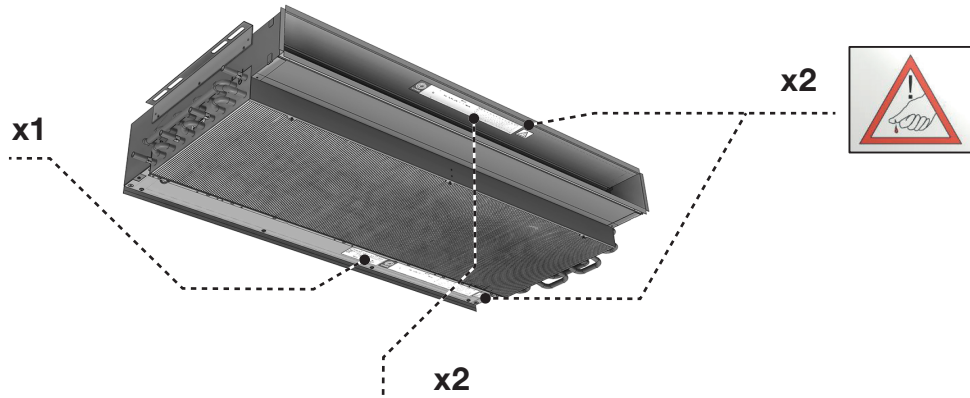
Order : xx-xxxxx
 Pos : xx
Munio-I-xxx-12-125-AK x,xx m
Pressure: AA Pa **Flow: BB l/s**
 Project : xxxxxxxx xxxxxxxx
 Mark : xxxxxx
 Nozzles : N/A Plugs : N/A Sign. : _____
 Product ID : xxxxxxxx





JetCones					
Date	ΔP_{tot} [Pa]	q [l/s]	1	2	Signature

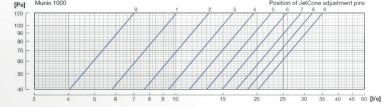

Installation instruction

Munio

2.12 Order code

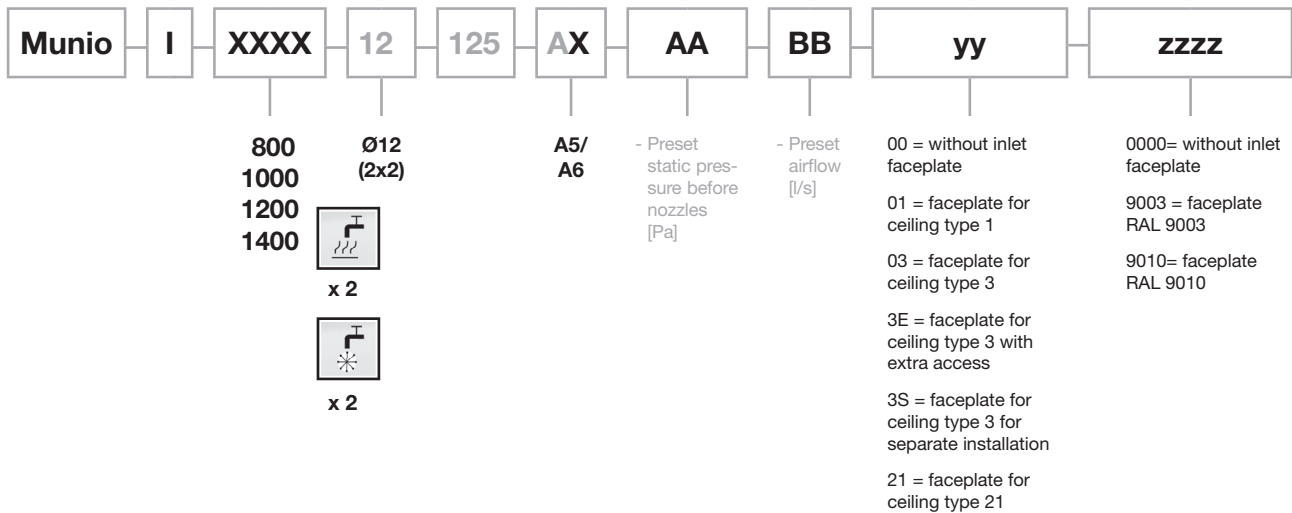
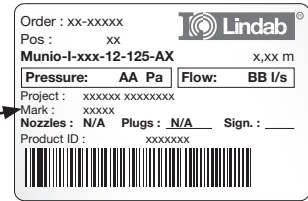
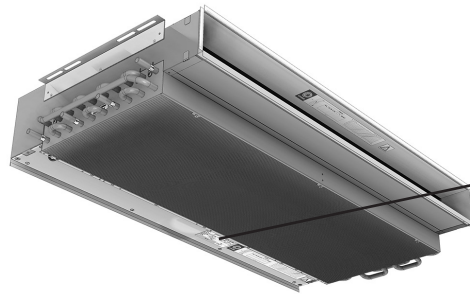

2.13 Order code example

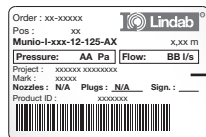

→ **Munio I-xxxx-12-125-12-A5-70-20-00-0000**

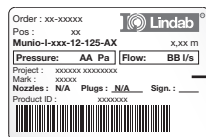

→ **Munio I-xxxx-12-125-12-A5-70-20-03-9003**

2.14 Label

On the label you'll find:

- Order: Order identification number.
- Pos: Order position.
- Product: Product configuration.
- Project: Project name.
- Mark: Marking noted on order.
- Product ID: Product number.
- Sign: To be signed when checked and commissioned on site.

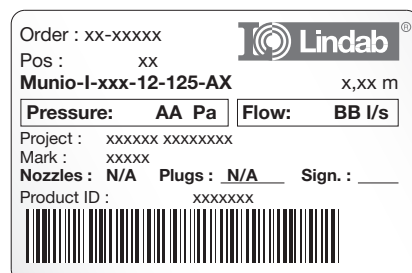

Installation instruction

Munio

2.15 Contents of order

Standard package/order contains:

- Beam
- Inlet faceplate (pre-installed or loose/separate)
- Plus features (pre-installed in factory)
- 4 pc/beam of copper insets (separate in smaller box)
- Accessories (separate in smaller box)

NB! Outlet front grille does not belong to the beam and needs to be ordered separately!

2.16 Plus features

2.16.1 Inlet faceplates

03, 3E Inlet faceplate included with Munio



2.16.2 Outlet front grilles (separate order and package)



Go to "Munio outlet grilles" for details.
www.lindqst.com -> Documentation -> Munio -> Related documents -> [AD21CN-M](#) and [AL21CN-M](#)

2.16.3 Integrated valves

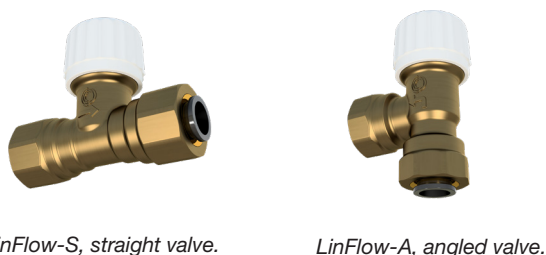

See [LinFlow-A](#) and [LinFlow-S](#) for details.

2.16.4 Thermoelectric actuators

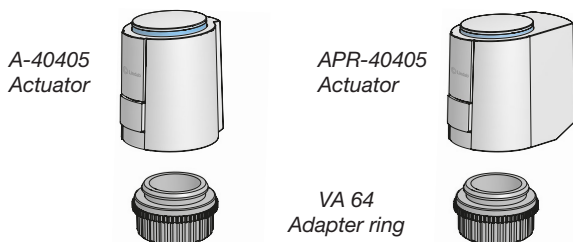

The actuators can be pre-installed on the integrated/ enclosed valves and connected to the integrated Regula connect card /Regula Secura (plus feature). Go to [Actuators](#) for details. See also [Adapter ring](#).

2.16.5 Integrated Regula components

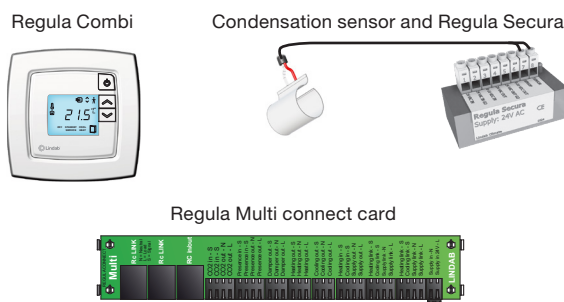

Go to [Regula](#) for details.

2.16.6 Airguides

Not relevant for Munio.

2.16.7 Heating

Available as standard for Munio.

2.17 Accessories

Here are some general accessories. For full range and order numbers, see separate [Accessories](#) document. The components under 2.16.3 to 2.16.5 are also available as accessories. Go to "8. Accessories" in this document to find accessories order numbers.

2.17.1 Threaded rod kit (Hangers)



M8
M8 x4 per beam when $L_{nom} \leq 2700$ mm
M8 x6 per beam when $L_{nom} > 2700$ mm

Go to 5.4 "Preparation for installation on the product" for more details. Order no: See [Accessories](#)

2.17.2 Flexible hoses

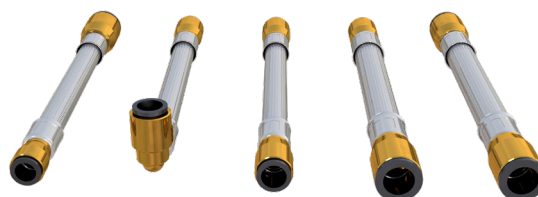

Order no: See [Accessories](#)

2.17.3 Transformer

Order no: See [Transformers](#)



2.17.4 Tectite fittings



Order no: 647690, 884050 and 642623 (12 mm).see [Accessories](#)

Installation instruction

Munio

3. Product specification

3.3 Munio

3.1 Product description

Lindab's active chilled beam unit Munio can be used for cooling, heating and ventilation. It has been developed for the installation and integration into bulkheads in hotel- and hospital rooms or for any other rooms with bulkheads.

- Small dimensions (800 x 540 x 170), high capacity.
- Ventilation, cooling and heating as standard.
- JetCone, an innovative way of regulating the air volume.
- No need for filter because it works with dry cooling.
- Service & maintenance issues are limited.
- For bulkhead installation with full integration in architectural design.
- Easy installation.
- Telescoping connection with clip in for outlet front grille.
- Full access with low cost maintenance.
- Fulfils highest hygienic requirements.
- Low sound levels.
- Individual room regulation with customized control equipment (plus).
- Additional energy savings when used with free energy sources.
- Lindabs active chilled beams are Eurovent-certified and tested according to EN-15116.



Munio active chilled beam.

3.2 Dimension

L = 800, 1000, 1200, 1400 mm
L = Nominal length (order length)

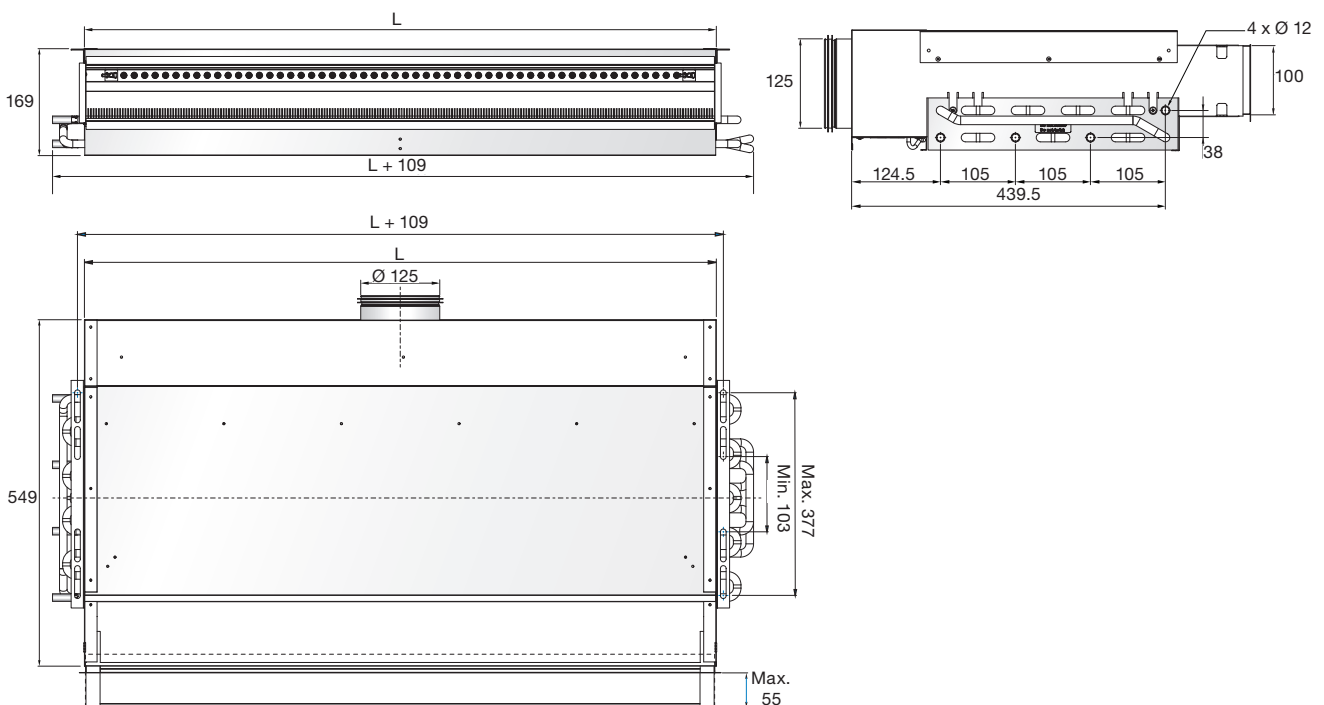

Dimension drawing.

3.4 Material data

Type	Munio I-800	Munio I-1000	Munio I-1200	Munio I-1400
Dry weight [kg]	12.1	14.7	17.3	19.9
Water content, cooling [l]	1.63	2.04	2.44	2.85
Water content, heating [l]	0.18	0.23	0.27	0.32
Copper pipes quality	EN 12735-2 CU-DHP			
Pressure class	PN10			

Table 1. Material data

3.5 Environmental Declarations

Please follow the links below:

- [Building product declaration](#)
- [Declaration of conformity](#)
- [Eurovent certificate](#)

3.6 Pressure Class

The waterborne products in Lindab, active chilled beams (battery products), passive chilled beams (battery and strips products), facade units (battery) and radiant panels (strips and panels) are produced according to pressure class PN 10 according to EN 1333: 2006.

This means the maximal working pressure for the products at a water temperature of 20°C must not exceed 10 bar.

3.7 Water quality

Lindab recommend water treatment and quality to be according to VDI 2035-2.

- The water preparation and maintenance for the chilled beam water circuit must be handled by a specialist.
- To prevent corrosion, the water circuit must be airtight.
- The water system must also be equipped with aerators to remove any build-up air in the system.
- The water must be oxygen free, to prevent corrosion.
- The water system must be filled with potable water that complies with the "EC directive 98/83/EC".
- pH value of water must be between approximately 6-9 pH.
- The water velocities should not exceed 1m/s, and should be kept as close to the nominal flow as possible to minimize noise and optimize the energy yield.
- Use in-line strainers to remove dirt particles from the water.
- If the water contains any additive inhibitor, then it must be appropriate to use with copper and solder.

3.8 Air quality

Primary supply air have to be clean, dry and filtered before reaching the beam.

3.9 Capacity test

Lindabs active chilled beams are Eurovent-certified and tested according to EN-15116.

Please visit [Munio](#) on www.lindQST.com and see [Eurovent](#) for more details.



Installation instruction

Munio

4. Connections

4.1. Water connections

Flow indication arrows are shown on the inlet and return pipes in order to assist the installer.

If the control valves have been ordered separately, a special direction of the flow must be upheld to ensure correct flow through the control valve. Please note the flow direction indicator on the valve to insure correct installation in relation to the desired flow.

When connecting a panel or a beam with the piping system either a push-on fitting or a compression coupling should be used. Lindab have tested and recommends John Guest push on fittings as well as push-on fittings from Tectite (available as accessory. See [Accessories](#)).

To avoid sound being transported over the beam, we recommend to use our flexible hoses between the piping and the beam connections. See [Accessories](#).

NB! Every control valve can create sound when it is installed directly connected to the water in- or outlet (or into the piping in close distance to the in- or outlet of the water product). To avoid unwanted sound generation we recommend to always use a Lindab control valve [LinFlow-A](#) (angled) or [LinFlow-S](#) (straight) and calculate the beam with the valve in [LindQST waterborne calculator](#).

4.1.1 Before installation

- Notice! The connection pipes are internally soft-welded, therefore it is not allowed to solder the beam to the pipes. For other than Lindab fittings and valves, please consult the installation guide for the specific fitting for further details on proper installation.
- Both inlet- and return pipes are covered by a plastic or rubber protection cover, which must be removed before installation.

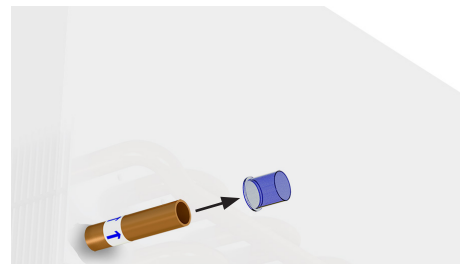

- After removing the protection cover, make sure that the pipe is intact and undamaged, especially at the pipe end, as even small dents and scratches potentially pose a risk of leakage in the system.
- Eventually deburr the pipe ends on the inside and the outside, using a deburring tool before installation.

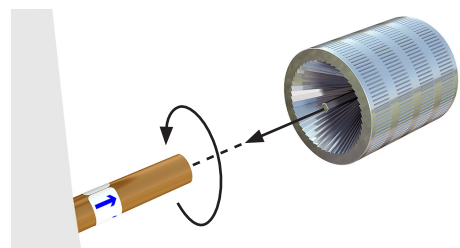
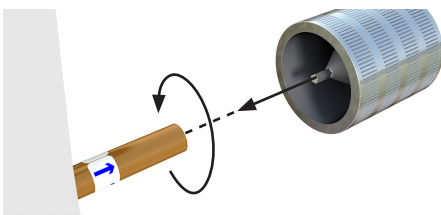
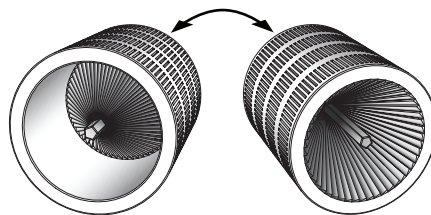

- Always remember to do a pressure test after assembly the pipe work.

Installation instruction

Munio

4.1.2 Push-on valve

- Mount a push-on valve to the pipe. Make sure the valve has the correct flow direction (see indication arrow on the valve) and that you have the correct valve, when integrated valve has been chosen (see indication on valve or follow cabelling to Regula Connect card). Cooper inserts aren't required!
- Please refer to the suppliers manual.

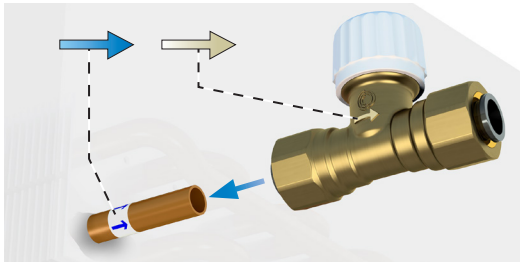

4.1.3 Compression fitting

- While mounting a compression fitting, the pipe will be exposed to a big amount of force, creating a risk of crushing the pipe. To ensure that the pipe won't be crushed when mounting the compression fitting, a copper insert must be inserted into the pipe (always part of the delivery).
- The copper insert should be placed inside the pipe on the beam. Always support the copper pipe coil when inserting the copper insert into position.
- Mount a compression coupling and/or a valve to the pipe. Don't stress the nut too much, since this may crush the pipe.
- Please refer to the suppliers manual.

4.1.4 Flexible hoses

- Our flexible hoses with straight ends can be used with both push-on and compression fitting.
- We recommend to use our flexible hoses with push-on fittings, for easier and faster mounting.
- For the connection to an enclosed valve with integrated push on coupling a flexible hose with straight end (male) or with push on (female) and a short copper pipe can be used.
- Please refer to the suppliers manual.

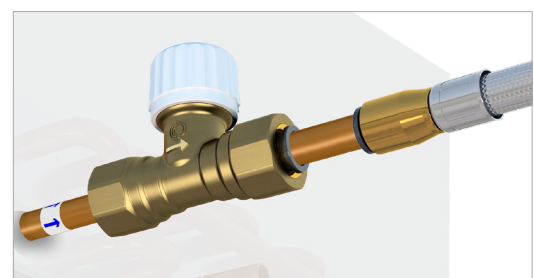
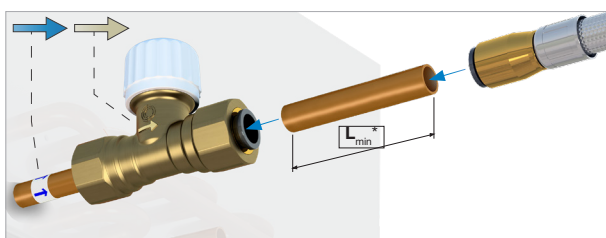
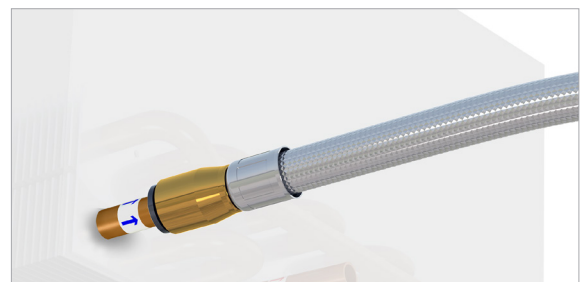
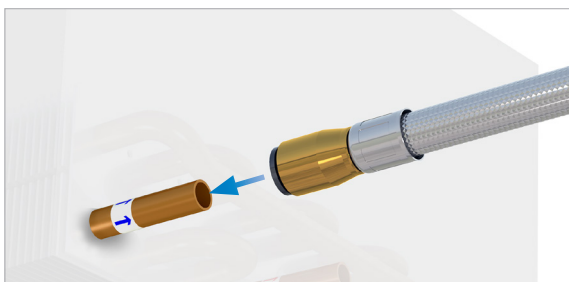

* $L_{min} = 70 \text{ mm}$ (to ensure you can open the couplings again).

Lindab flexible hoses are available with straight end (male) for direct connection to Lindab valves also.

Installation instruction

Munio

4.1.5 Possible connections water cooling (2-pipe)

The active chilled beam Munio is in the standard version always equipped with a so called “4-pipe connection” and contains two water circuits. If the connection is a “2-pipe”, as in a change-over system, or if Munio is to be used for cooling only, the heating connection can be left unconnected.

4.1.6 Possible connections water cooling and heating (4-pipe)

Munio has a 4-pipe water connection at the left (-6) or at the right side (-5), seen in the direction of the air connection. The dimension for all connections are 12 mm.

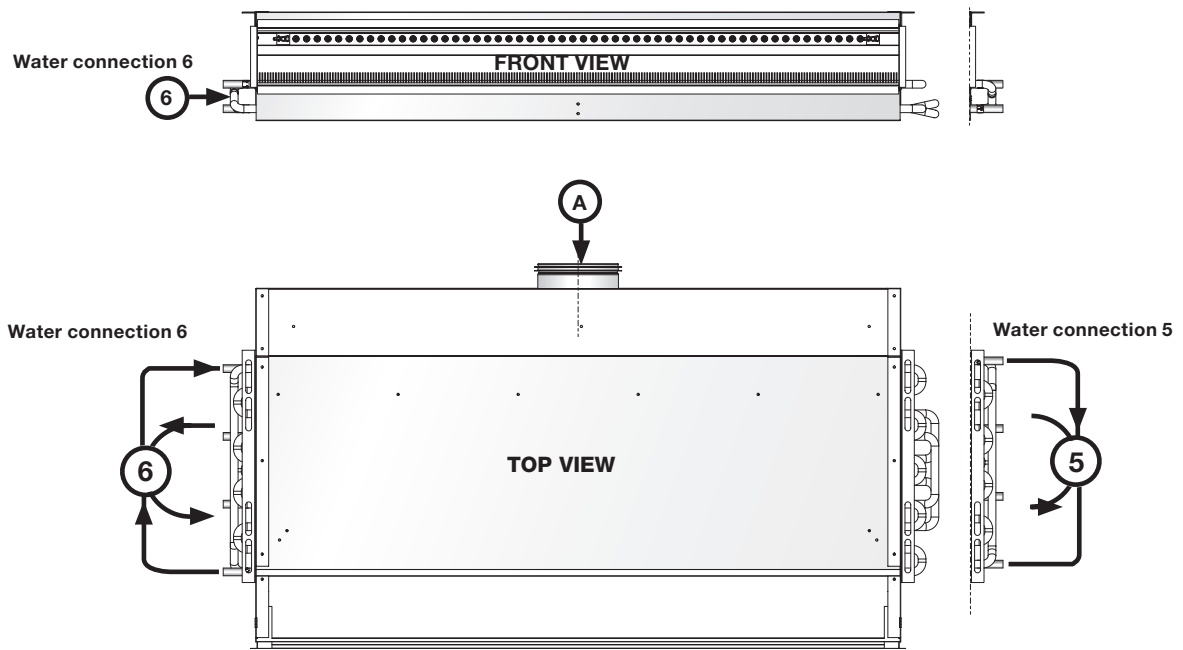

Water connections (5 or 6) for Munio-I.

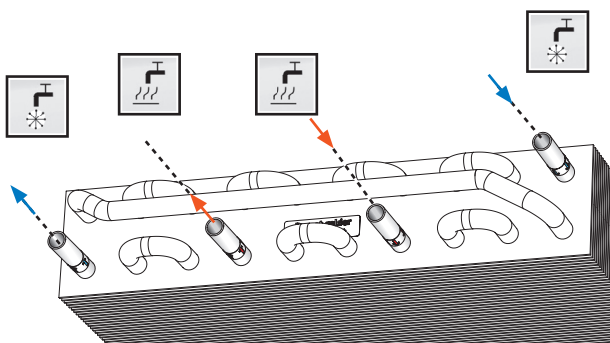

Placement of cooling and heating pipes (12 mm) on the battery.

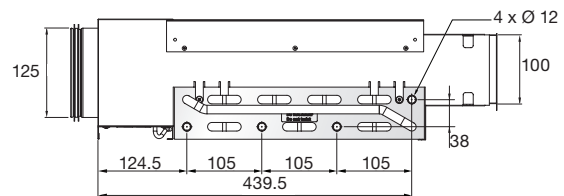

Munio-I placement of connections (Battery in A6 position).

4.2. Air connections

4.2.1 Air connection installation

The primary air supply must be connected with instructions from a ventilation specialist. Lindab's chilled beams can beneficially be used together with Lindab's Safe® duct systems.

We recommend a flexible duct connection, like Lindab DRATMFU-125, to balance out different installation heights or directions between connection and duct and avoid sound will be diverted from piping system to the ceiling.

4.2.2 Possible connections supply air

The Munio has one possible supply air connection (A) (horizontal back connection). To achieve other directions than horizontal we recommend using either a Lindab BKMU-90-125 or DRATMFU-125.

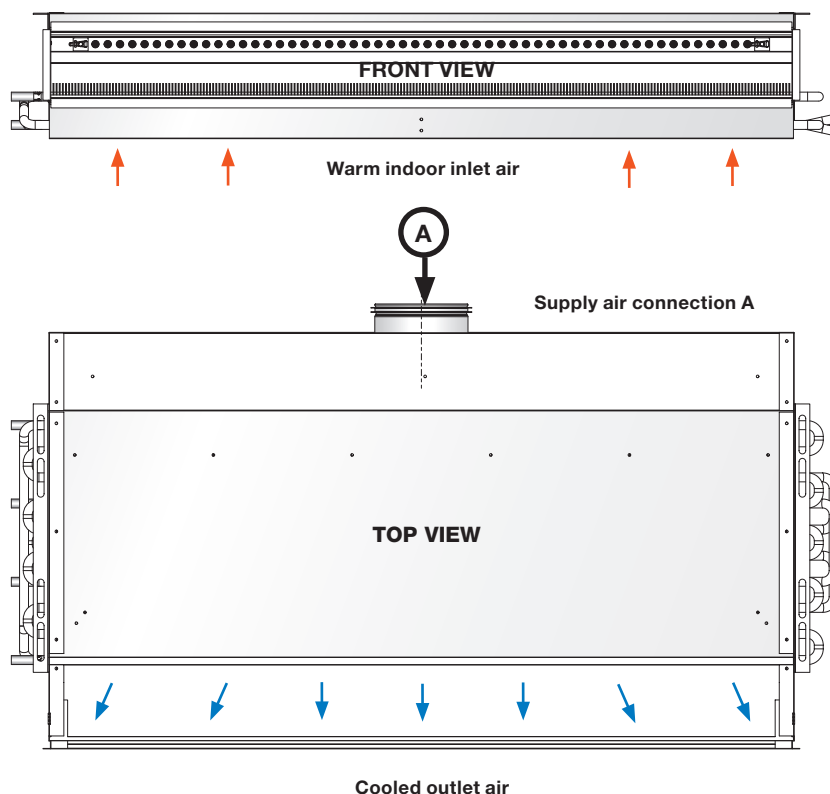

Supply air connection A for Munio-I.

4.2.3 Possible connections exhaust air

Munio has no possibility to integrate exhaust air.

4.3 Possible combination of connections

For Munio the only possible connections are A5 and A6 (see picture 14), all connections horizontal with air back-connection (A; 125 mm) water on left side (A6, 12 mm) or water connections on right side (A5, 12 mm), direction of supply air.

Installation instruction

Munio

4.4 Electrical connections

Electrical connections on the beam are only necessary, when plus features are chosen and thanks to the pre-fabrication it is as easy as “plug and play”. All regula components will be installed on the inspection hatch which then comes with service-wires. The components are always installed near the water-connection at the end of the beam.

For further information, see Waterborne indoor climate solutions - Regula.

Go to www.lindQST.com -> Waterborne documentation -> [Regula Combi](#) -> Related Documents

Also see: www.lindQST.com -> Waterborne documentation -> [Regula](#)

4.4.1 Regula components on the beam

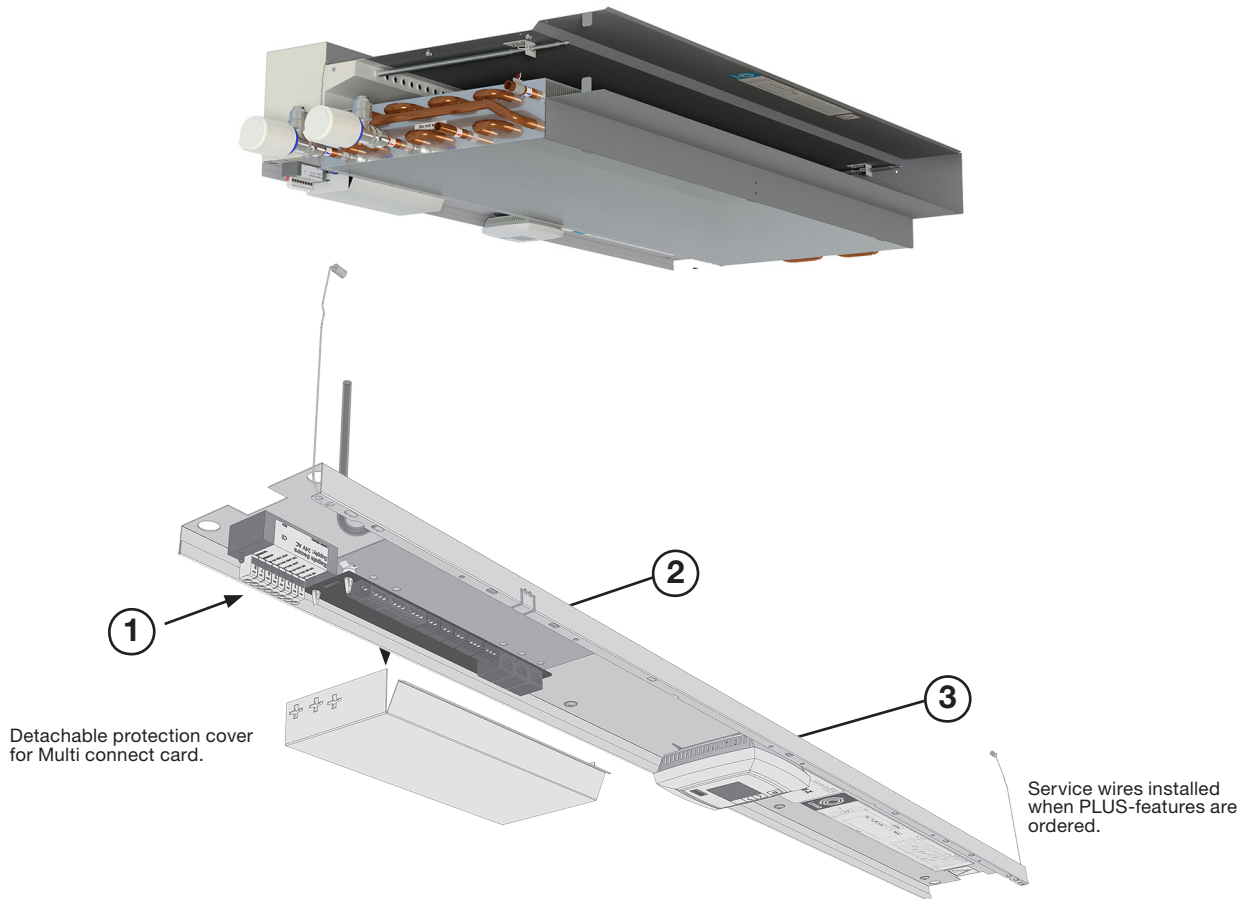

1 Detachable protection cover for Multi connect card.

Service wires installed when PLUS-features are ordered.

1 Regula Secura Sensor

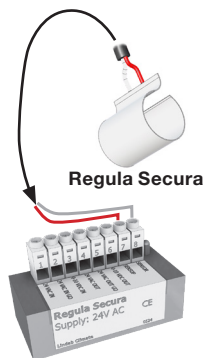

Regula Secura Sensor
Condensation sensor installed on cold-water-IN pipe. The sensor is connected and controlled by the Regula Secura.

2 Regula Connect Cards

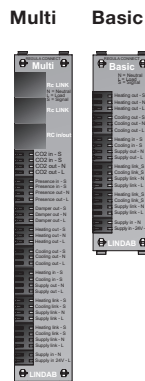

Regula connect cards Multi / Basic
Connect cards come with protection covers, fully cabled to included features.

3 Regula Combi

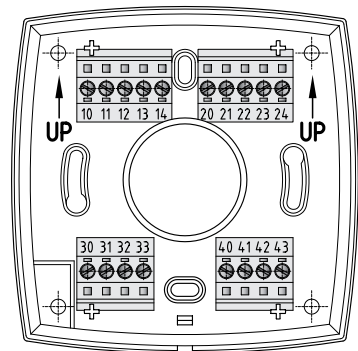

Regula Combi
Easy take off front gives directly access to connection-plinths. In single rooms arrangements the Regula Combi can also be placed on a room wall to enable easy access.

Regula components on the beam.

Installation instruction

Munio

4.4.2 Example 1: Wiring scheme with Regula Connect multi

Please visit www.lindab.com and check out the "Wiring scheme configurator" for your set-up.

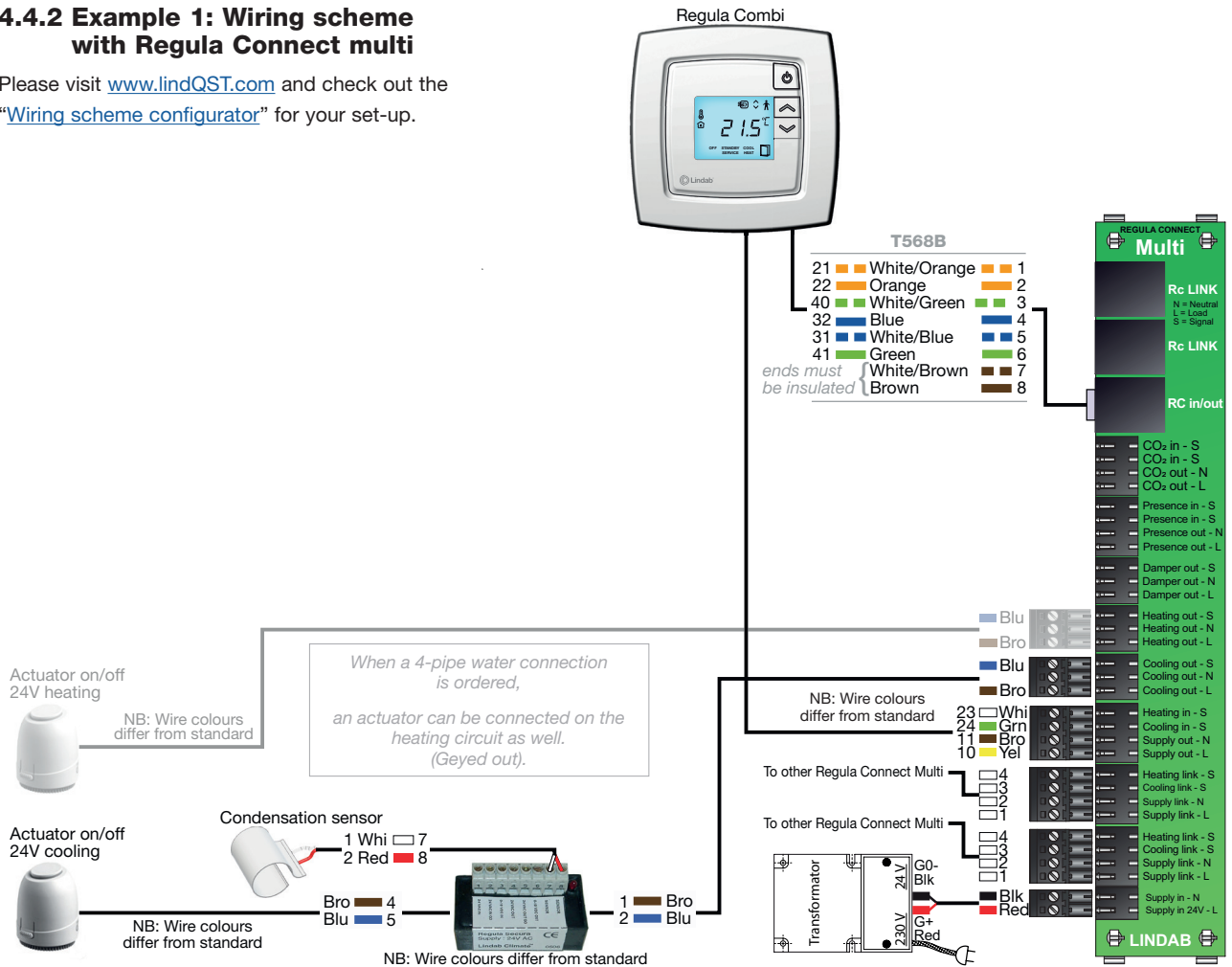

Example 1 Wiring scheme.

4.4.3 Example 2: Wiring scheme with Regula Connect basic

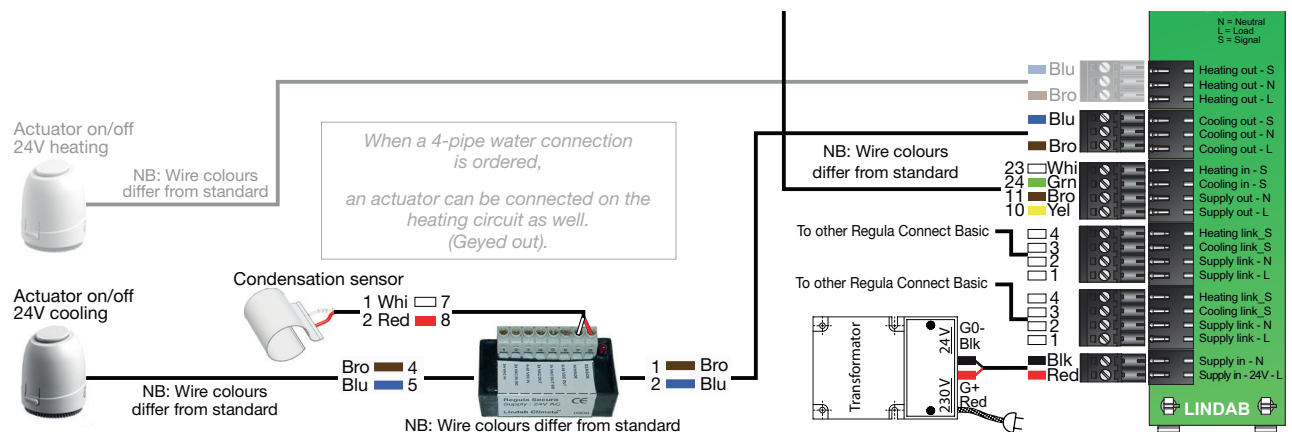

Example 2 Wiring scheme.

Installation instruction

Munio

4.4.4 Regula Connect on the beam

Connect cards are pre-installed when the beam is ordered with plus features. See [Regula Connect](#) for more details.

Regula Connect Basic



Regula Connect Pascal



Regula Connect Multi



4.4.5 Regula Secura on the beam

Regula Secura is pre-installed when the beam is ordered with plus features. See [Regula Secura](#) for more details.

Condensation sensor and Regula Secura

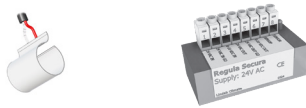

Cable to Regula Secura

Protection cap

Condensation sensor

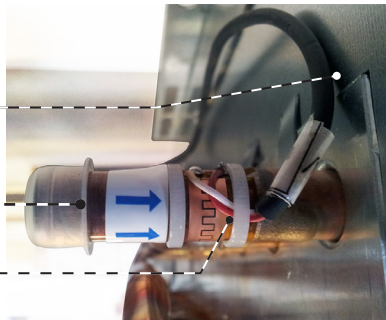

Regula Secura with condensation sensor preinstalled on Munio battery cold water inlet pipe.

4.4.6 Valves and Actuators on the beam

Description, see 2.16.

4.4.7 Regula Combi on/with the beam

The Regula Combi can be controlled and programmed locally in the display, or at a remote location by a EXOLINE or MODBUS communication system. Handles both 24 V and 0-10 V devices.



See the [Regula Combi](#) documentation.

4.4.8 Actuators

Description, see 2.16.



5. Installation of product

5.1 Handling of product

For the handling of the product please refer to 2.5.

5.2 Adaption to ceiling systems

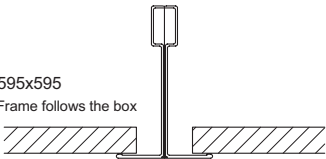
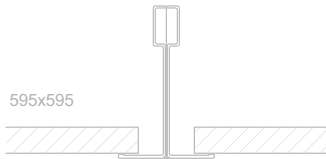
5.2.1 Ceiling systems

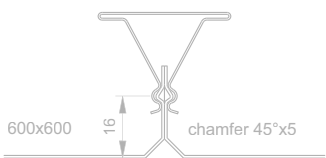
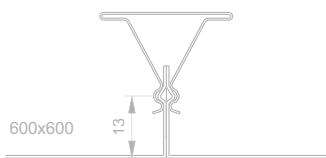
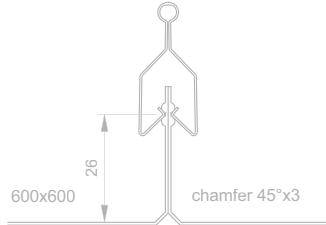
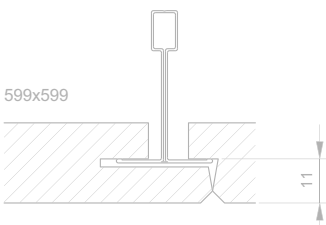
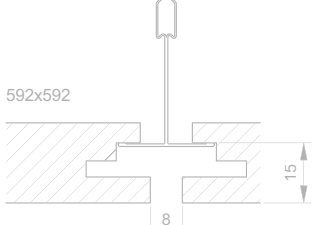
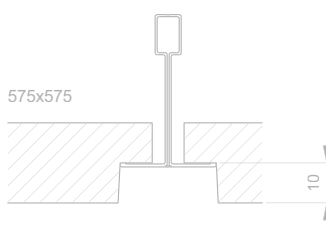
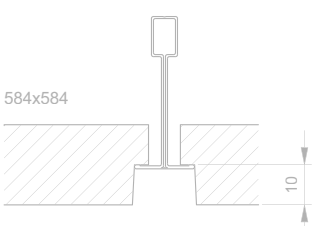
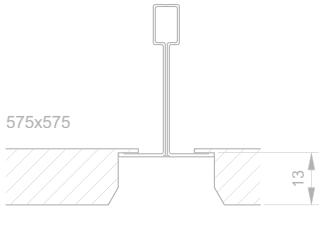
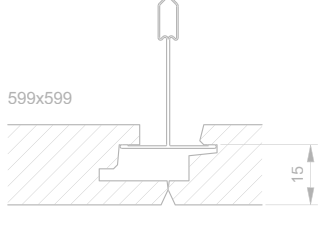
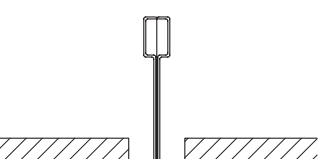
<p>① T24/T15 Lay-in 600 (I-60) Water Danotile T24/T25 Ecophon T24 Rockfon A24</p> <p>595x595 Frame follows the box</p> 	<p>② T24/T15 Lay-in 600 - not cleanable (I-60) Water</p> <p>595x595</p> 	<p>③ Permanent ceiling (I-60) Water</p> <p>400: 383x383 500: 463x463 600: 563x563</p> 
<p>④ Dampa Clip-in bevelled edge (X) Water</p> <p>600x600 16 chamfer 45°x5</p> 	<p>⑤ Dampa Clip-in square edge (X) Water</p> <p>600x600 13</p> 	<p>⑥ Luxalon SQ Clip-In (X) Water</p> <p>600x600 26 chamfer 45°x3</p> 
<p>⑦ Danotile Contur (X) Water Ecophon D Rockfon D-XL</p> <p>599x599 11</p> 	<p>⑧ Ecophon Focus DG (I) General Water (I) Plexus 594 x 594 (J) Professor</p> <p>592x592 15 8</p> 	<p>⑨ Rockfon E10, 24 (Y) Water Ecophon - E / T24</p> <p>575x575 10</p> 
<p>⑩ Rockfon E10, 15 (Z) Water Ecophon - E / T15</p> <p>584x584 10</p> 	<p>⑪ Danotile Markant (Y) Water</p> <p>575x575 13</p> 	<p>⑭ Ecophon Focus DS (X) Water Rockfon Sonar X</p> <p>599x599 15</p> 
<p>⑰ T24/T15 Lay-in-625 (I-62) Water</p> <p>⑱ T24/T15 Lay-in-625 not cleanable (I-62) Water</p> 		

Installation instruction

Munio

5.3 General installation principles

5.3.1 Recessed in suspended T-bar ceiling.

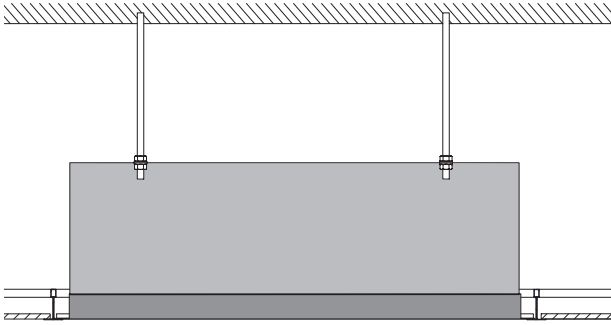

5.3.2 Exposed, sealed to the ceiling.

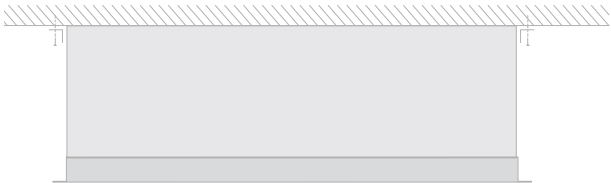

5.3.3 Exposed, free hanging.

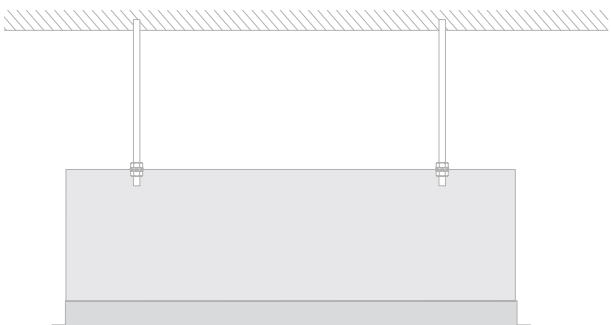

5.3.4 Free hanging above perforated or egg-crate ceiling.

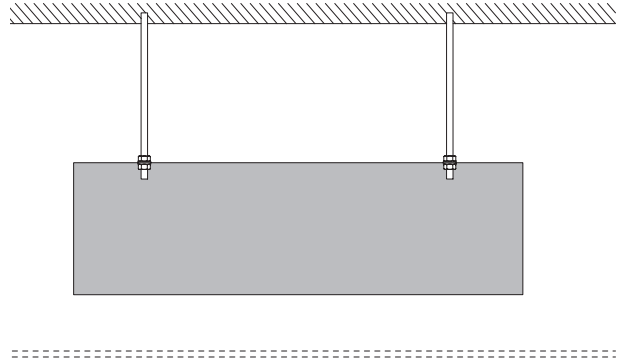

5.3.5 Recessed in suspended (permanent) ceiling with cover flanges.

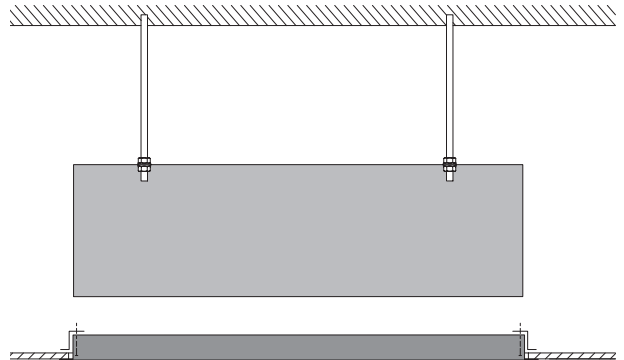

5.3.6 Recessed in suspended (permanent) ceiling without cover flanges.

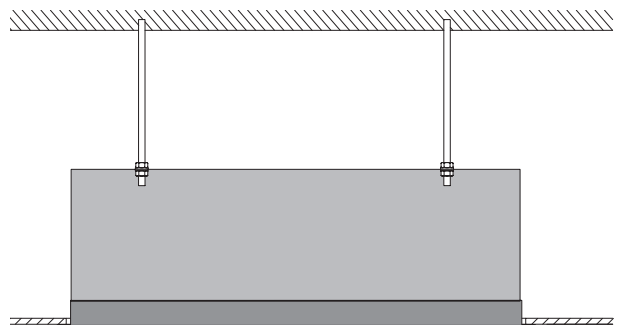

Installation instruction

Munio

5.4 Preparation for installation on the product

The beam is prepared for installation of hangers (4 x per beam) by two bars including four long holes ready for:

- Pendulum hangers (in different sizes)
- Threaded rods M8
- Wiring hanger system

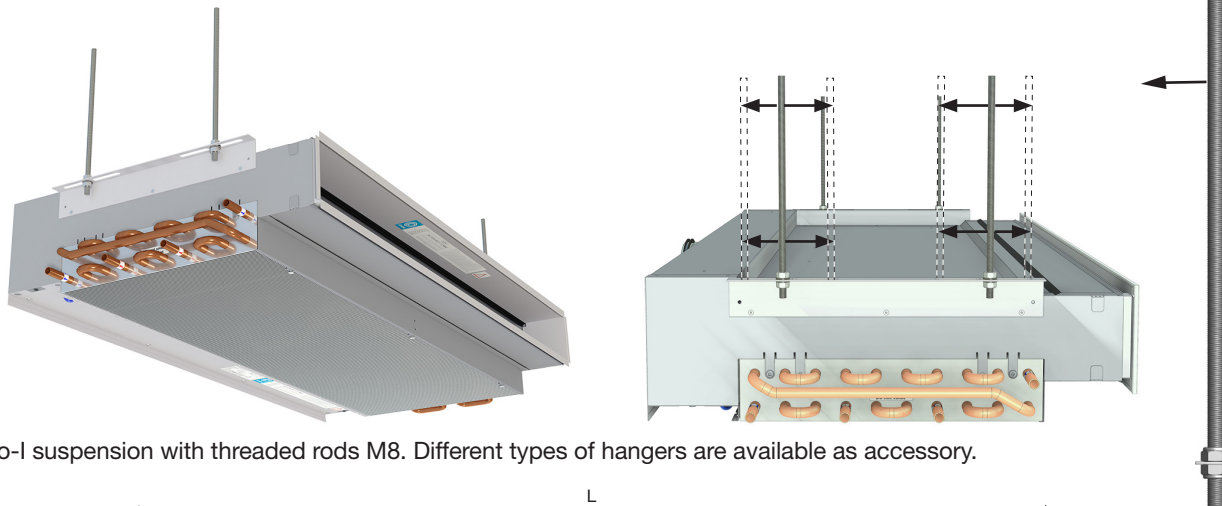

Munio-I suspension with threaded rods M8. Different types of hangers are available as accessory.

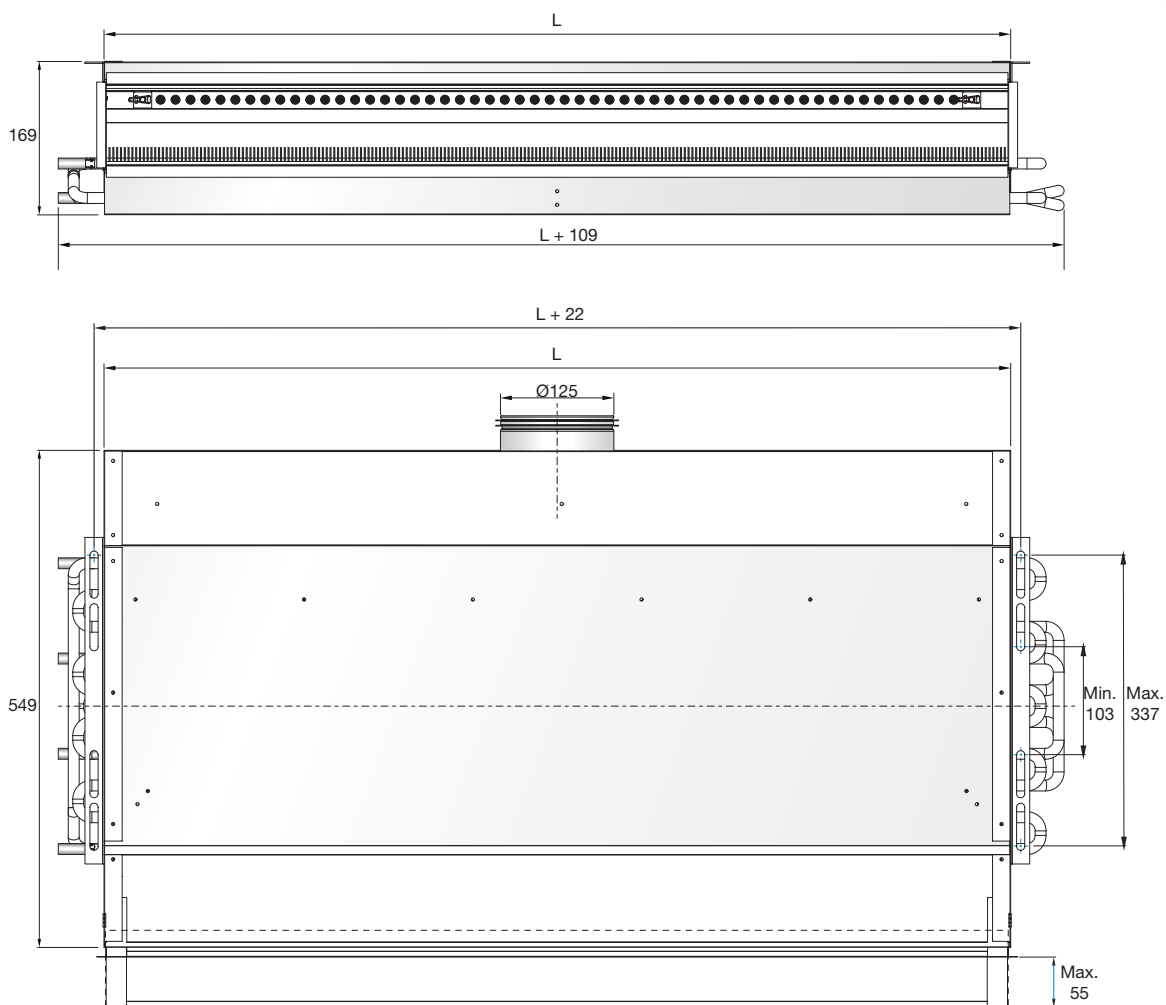

L = 800, 1000, 1200, 1400 mm
L = Nominal length (order length)

Hanger preparations sizes and dimensions.

Installation instruction

Munio

5.5 Preparation for installation of the product

5.5.1 Cutout dimensions in the bulkhead.

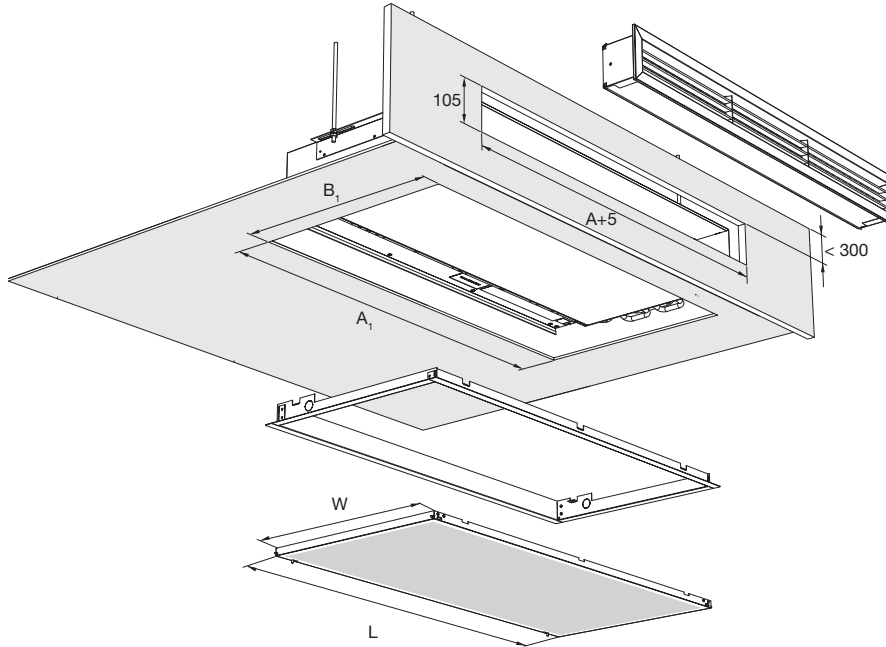

Bulkhead integration and cutout dimensions.

Inlet faceplate cutout dimensions

The cutout dimensions A_1 and B_1 for inlet faceplates are:

$$A_1 = L_{\text{inlet}} - 25 \text{ mm} \quad \text{and} \quad B_1 = W_{\text{inlet}} - 25 \text{ mm}$$

Order code	Ceiling Type	Munio-I		Inlet faceplate				Weight
				L_{inlet}	W_{inlet}	Cutout		
		L	Width			A_1	B_1	
		[mm]						[kg]
	3	Inlet faceplate -03 mounted to Munio (SHORT version)						
03		800	549	844	505	820	480	2.8
03		1000		1045		1020		3.2
03		1200		1245		1220		3.7
03		1400		1445		1420		4.1
		Inlet faceplate -01 and -21 separate from Munio for lay-in ceiling						
01	1	1200	600	1193	593	- *	- *	3.5
21	21	1200	625	1243	618	- *	- *	3.7
	3	Inlet faceplate -3S separate from Munio mounted into the ceiling						
3S		1200	549	1193	593	1168	568	4.6
	3	Inlet faceplate -3E mounted to Munio (LONG version)						
3E		800	549	1175	505	1150	480	3.6
3E		1000		1375		1350		4.1
3E		1200		1575		1550		4.5
3E		1400		1775		1750		5.0

Table 2. Munio cutout sizes, dimensions and weights for different inlet face plates.

***NB!** Ceiling type 1 and 21 do not have a cutout. The inlet faceplates lay-in freely in T24/T15 ceilings. (Please check with ceiling supplier if weight is covered or hang separately.)

Installation instruction

Munio

5.5.2 Basics steps of installing the product

It is recommended to use inlet face plate types 03, 3E or 3S for ceiling type 3.

STEP-1 De-install inlet faceplate with frame (only necessary for type 03 an 3E, see order code).

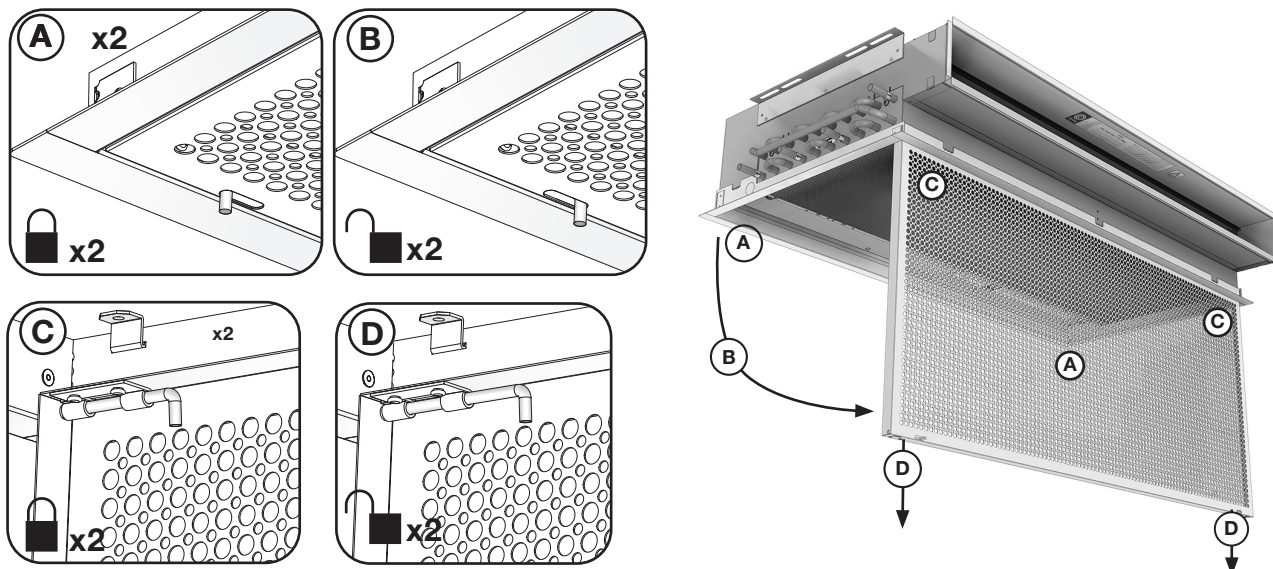

NB!

Only follow step-E, when inlet faceplate type -03, has been chosen. For all other scenarios, skip step-E. The inlet faceplate comes separately and the frame will not have to be de-installed/installed to the Munio.

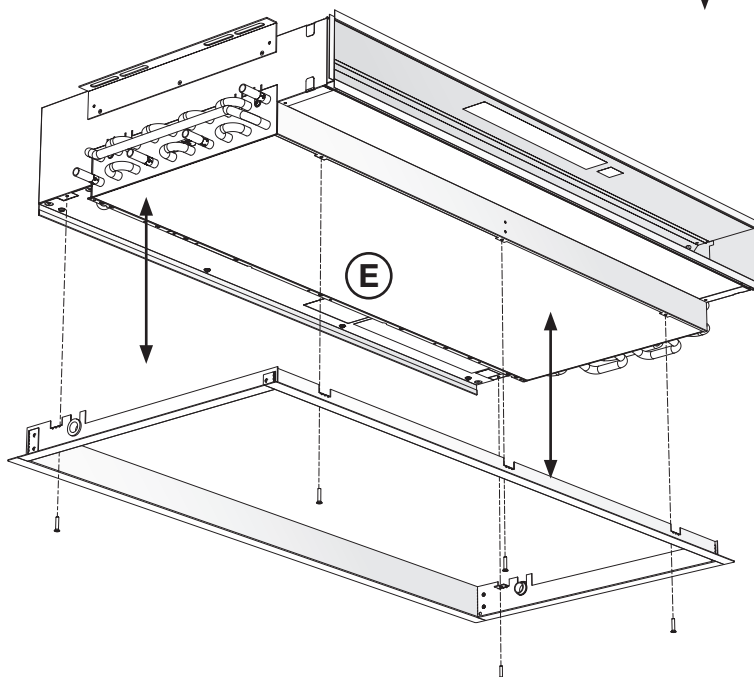
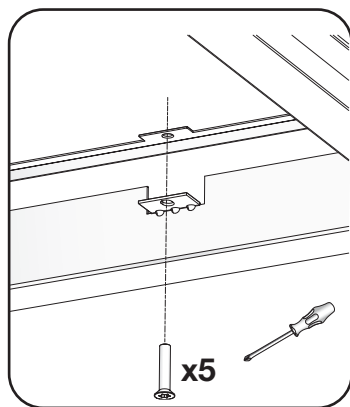

STEP-2 Remove the telescopic extension piece.

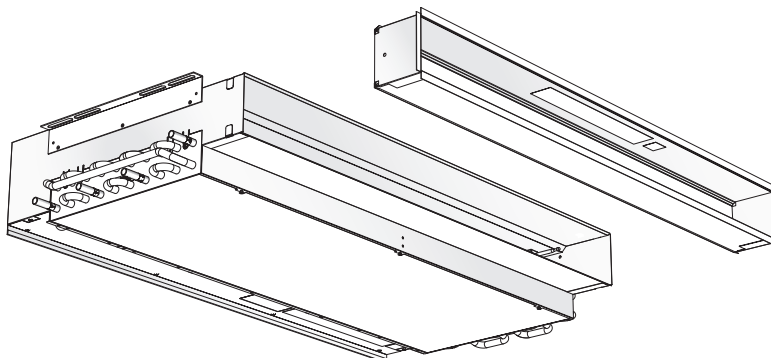

Installation instruction

Munio

STEP-3 Install basic Munio in ceiling (shown with threaded rods, other hangers accordingly to instruction).

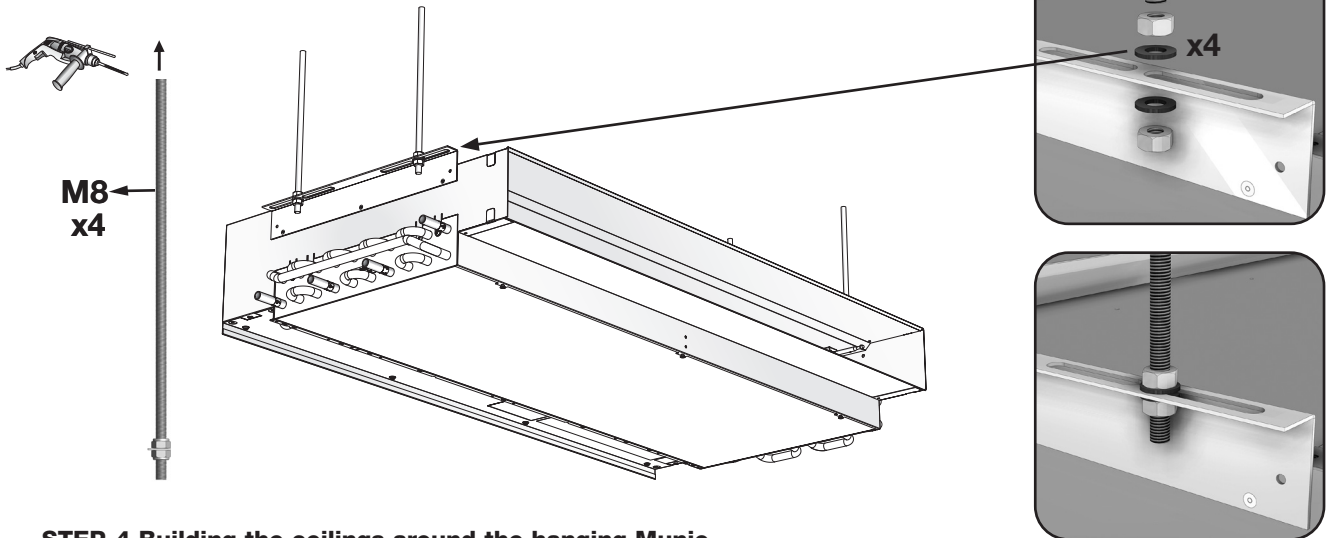

STEP-4 Building the ceilings around the hanging Munio.

Ceiling 3: Permanent ceiling

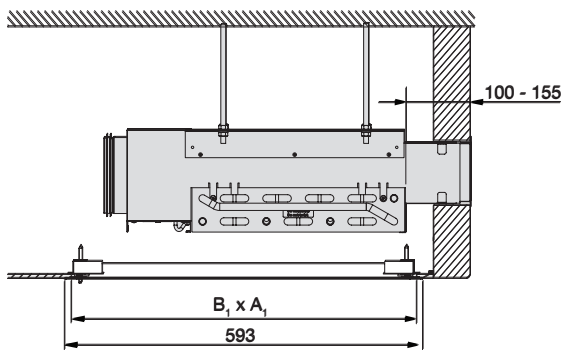

Prepare your cut-out for the transition piece: (A + 5 mm) x 105 mm (A=L).
Prepare your A₁ x B₁ cut-out for inlet-faceplate.

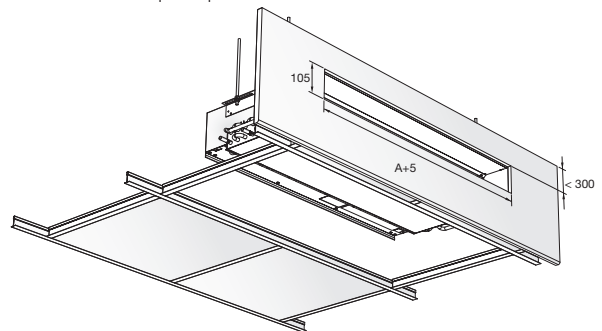

Installation sketch for Inlet faceplate -3S with cutout dimensions.

Ceiling 1, 21: T24 /T15 lay-in 600 / 625

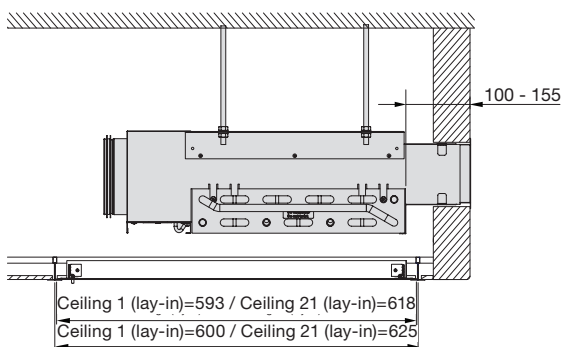

Prepare your cut-out for the transition piece: (A + 5 mm) x 105 mm (A=L).

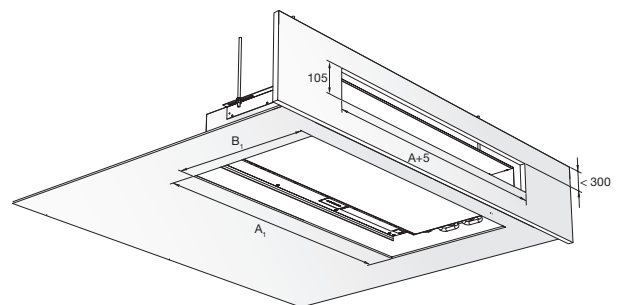

Installation sketch for inlet faceplate -01/-21 with cutout dimensions.

NB! Step 1-4 shows scenario when ceilings are built AFTER Munio are installed. If the ceiling is pre-built (sometimes the case for T-ceilings), step-4 will become step-1 and other steps 2-3-4.

Installation instruction

Munio

STEP-5 Installing telescopic expansion piece

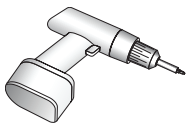
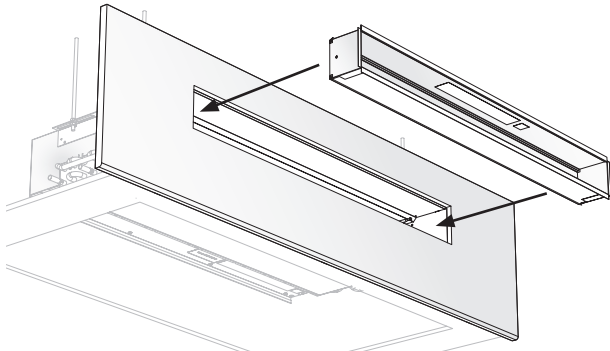

Use 2x self drilling screws (not included).

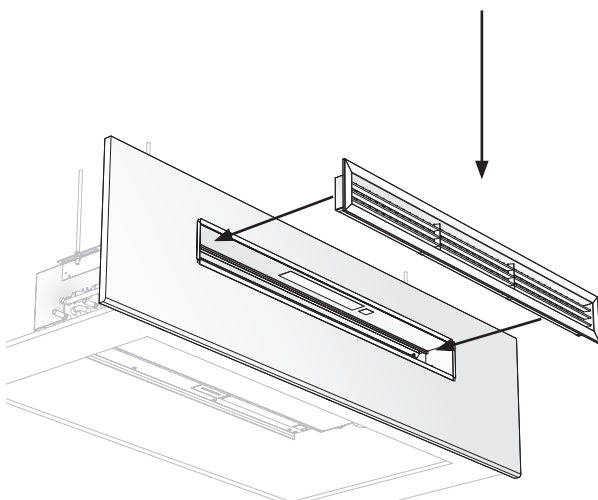
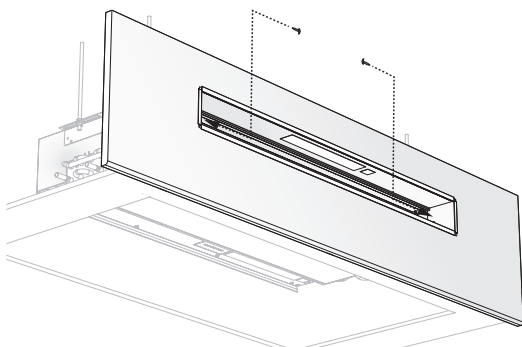

STEP-6 Insert outlet front grille

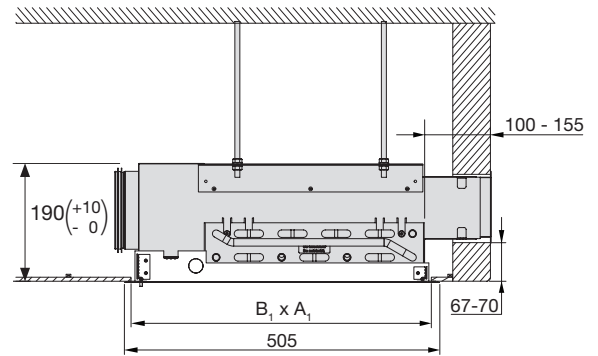

Installation sketch for Inlet faceplate -3 and -3E with cutout dimensions.

Installation instruction

Munio

STEP-7a Installing inlet faceplate 03/3E.

Recessed in suspended (permanent) ceiling without cover flanges.

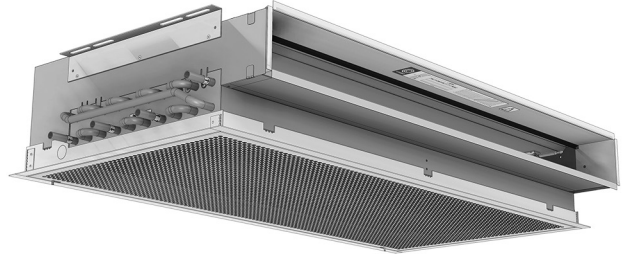
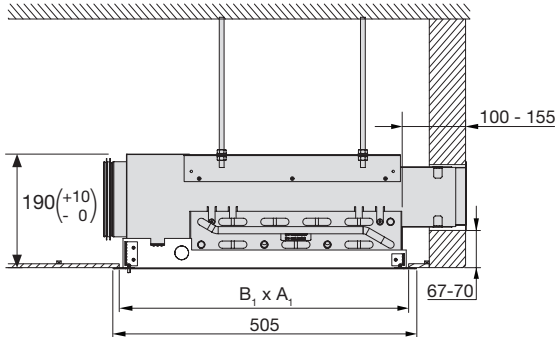

Follow step 1-6 and the inlet faceplate is ready to be installed. Start with the frame and the faceplate afterwards.

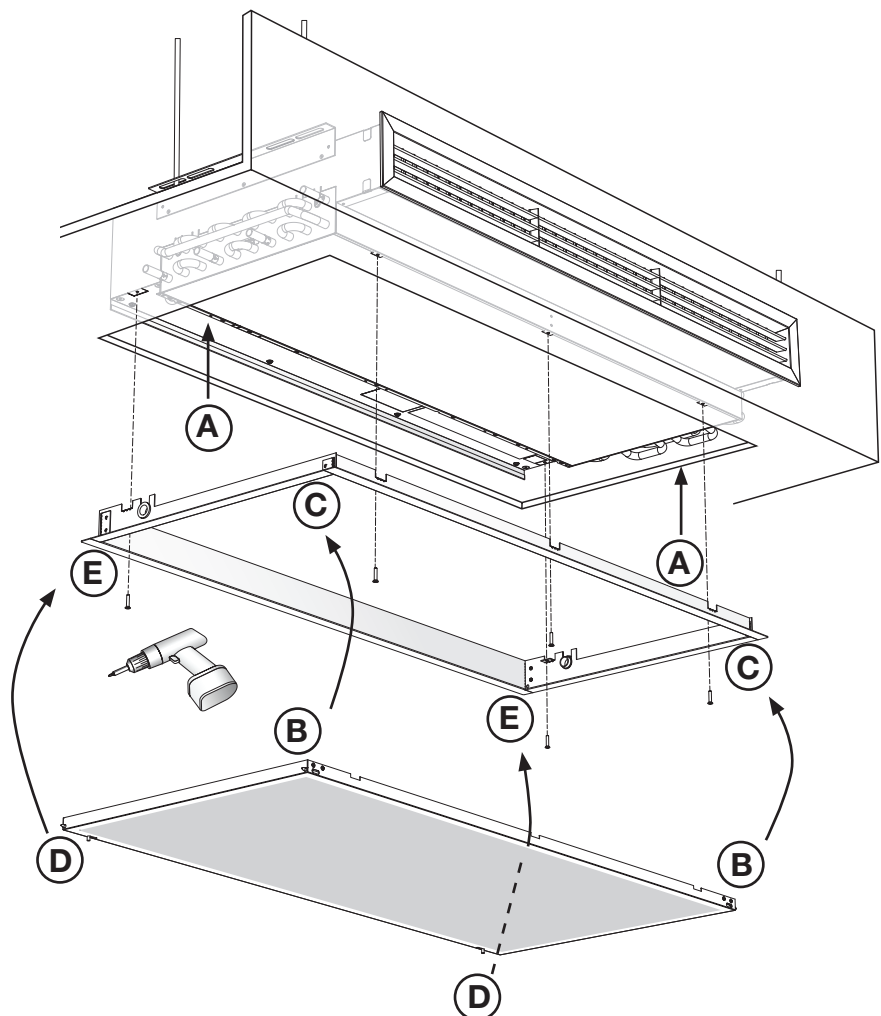
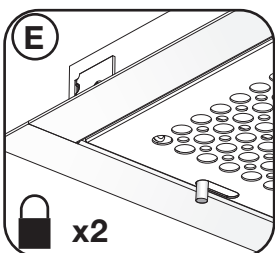
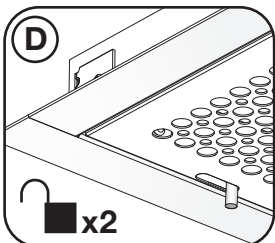
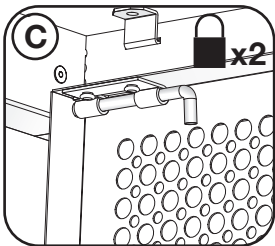
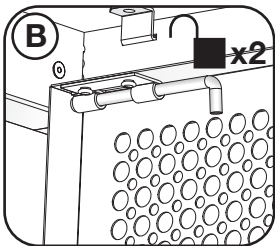
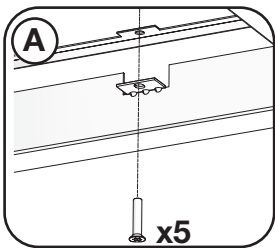

NB! The frame can be used as a transition piece (0-10 mm) together with the screws for example to cover irregularities of or towards the ceiling.

Installation instruction

Munio

STEP-7b Installing inlet faceplate type 3S in ceiling type 3.

Recessed in suspended (permanent) ceiling with cover flanges

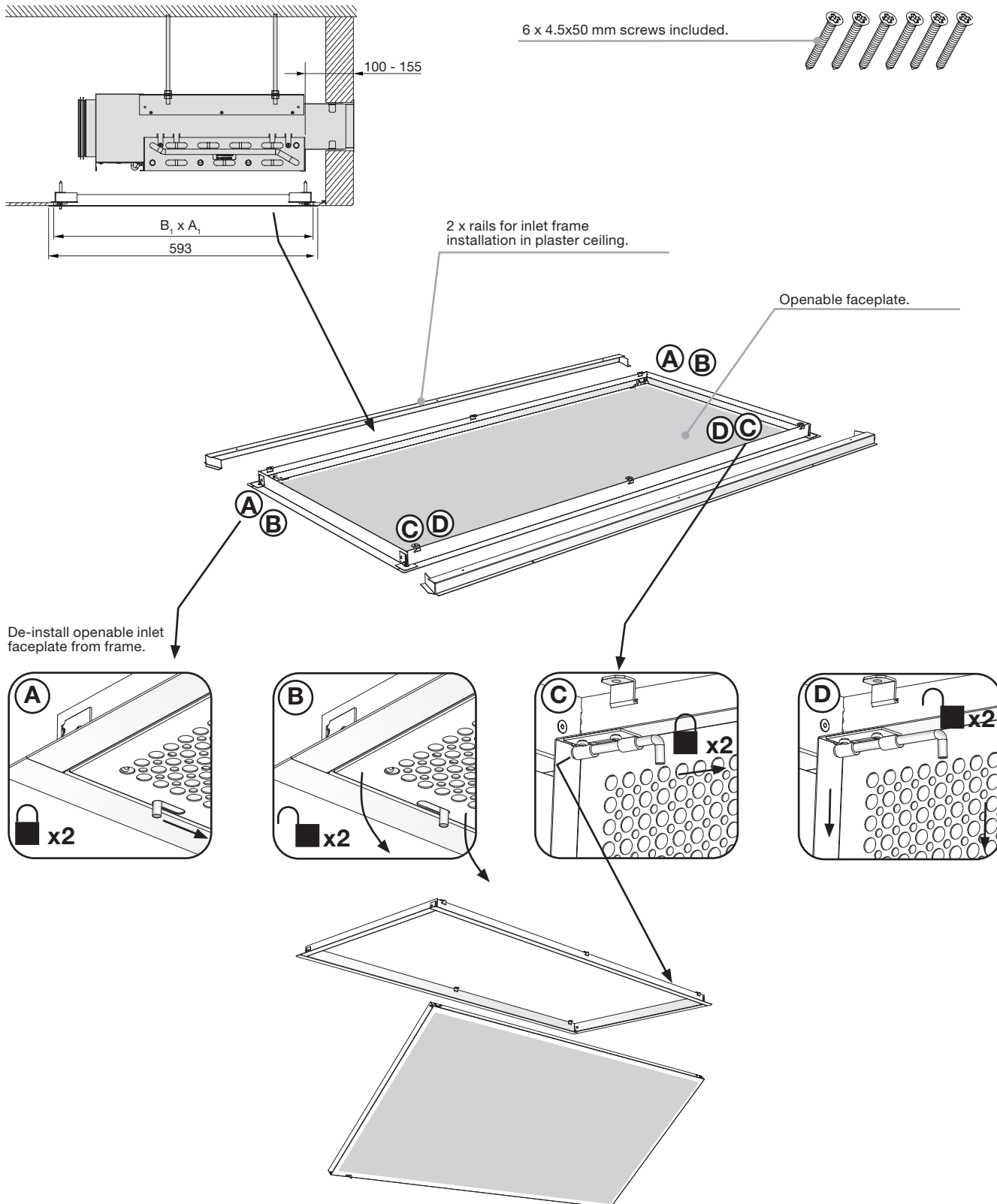

Installation instruction

Munio

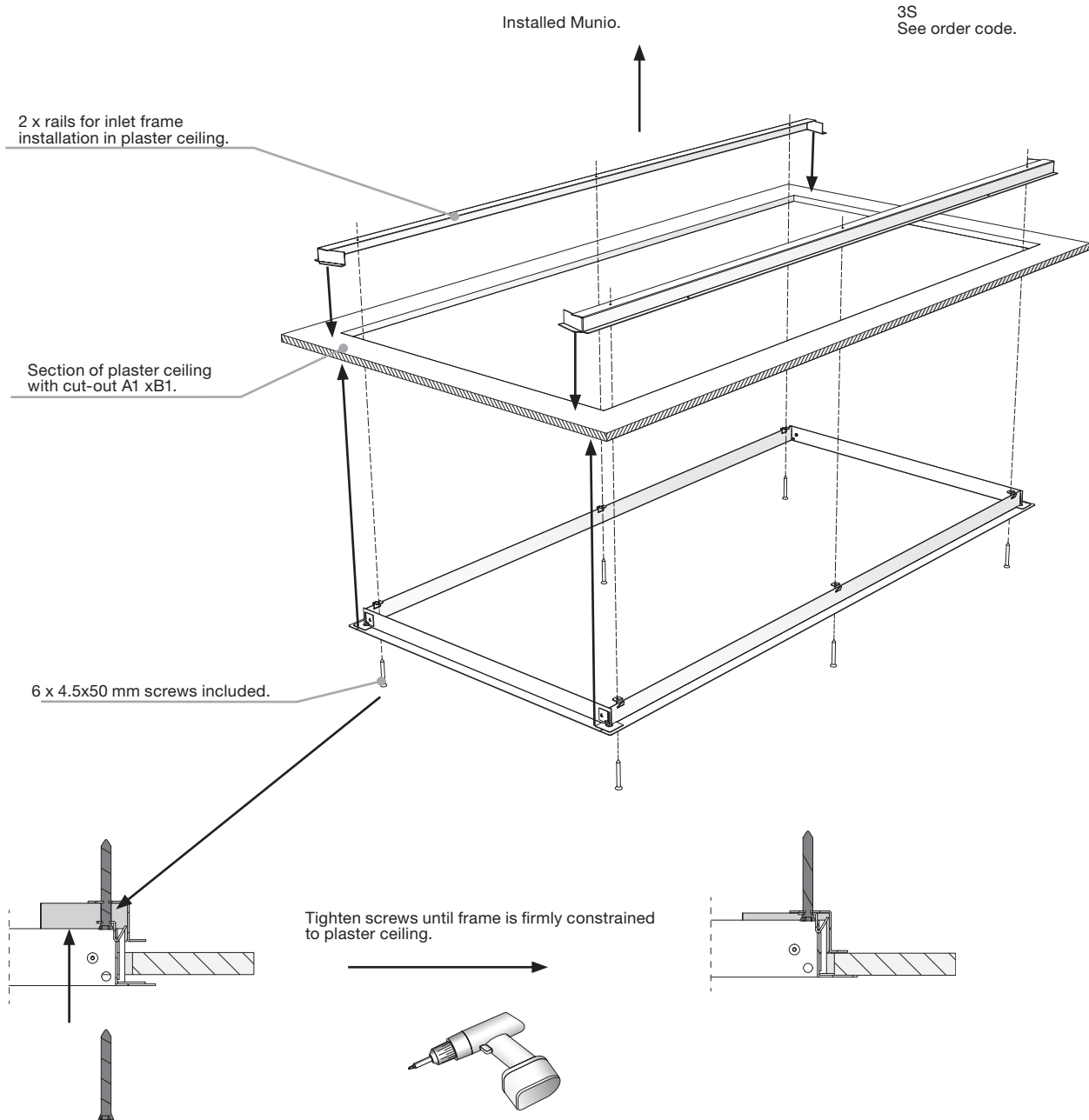

Installing inlet faceplate type 3S in ceiling type 3.

Installation instruction

Munio

STEP-7c Installing inlet faceplate type 01/21 ceiling 1,21 (T-ceiling)

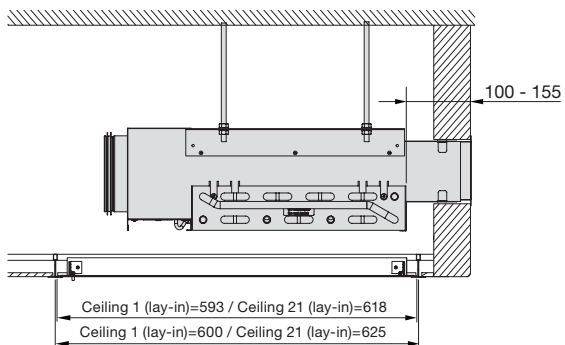

Make room for 1200 Inlet faceplate.
Remove ceiling plates and t-rails.

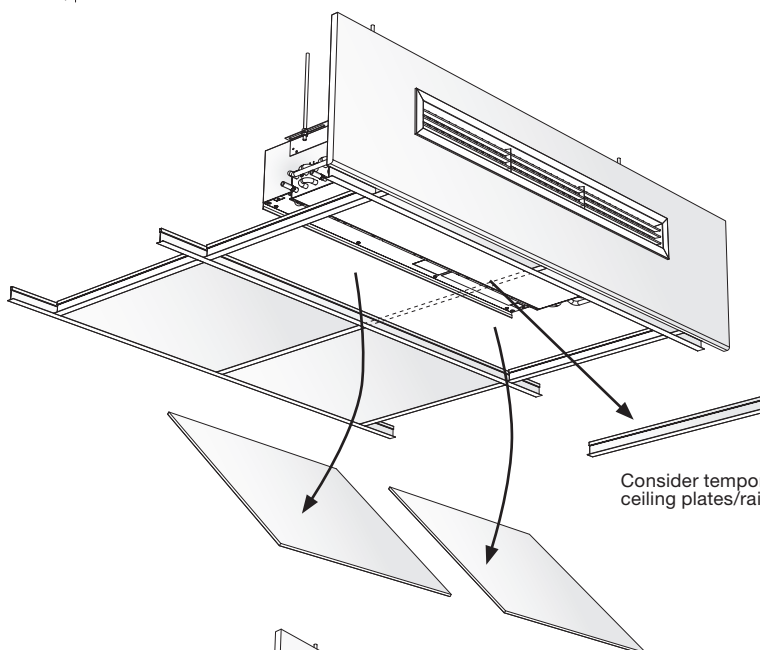

Consider temporarily to move extra ceiling plates/rails for better access.

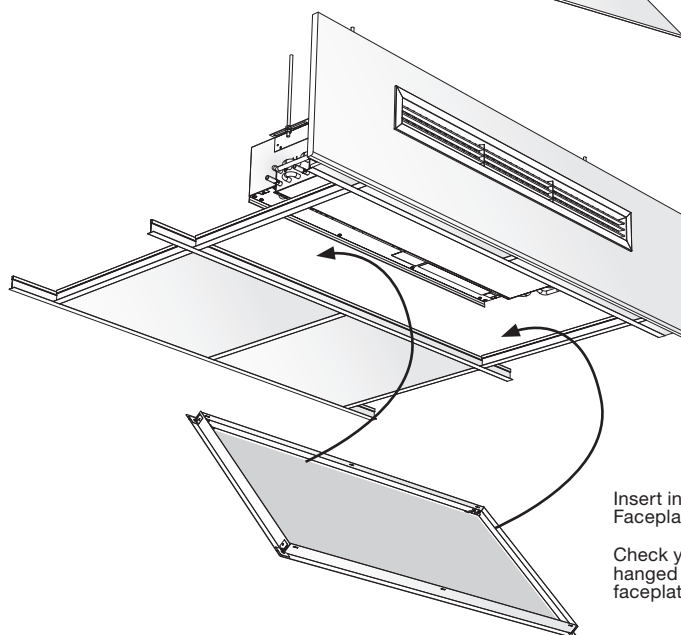

Insert inlet faceplate. No tools needed.
Faceplate lies freely in suspended ceiling.

Check your ceiling system is properly
hung to take weight of the inlet
faceplate.

Installation instruction

Munio

6. Adjustment and commissioning

6.1 Airflow and pressure

The JetCone System enables an easy and fast adjustment in both pressure and air volume (primary airflow rate) through the front side.

6.1.1 Jetcone adjustment pins

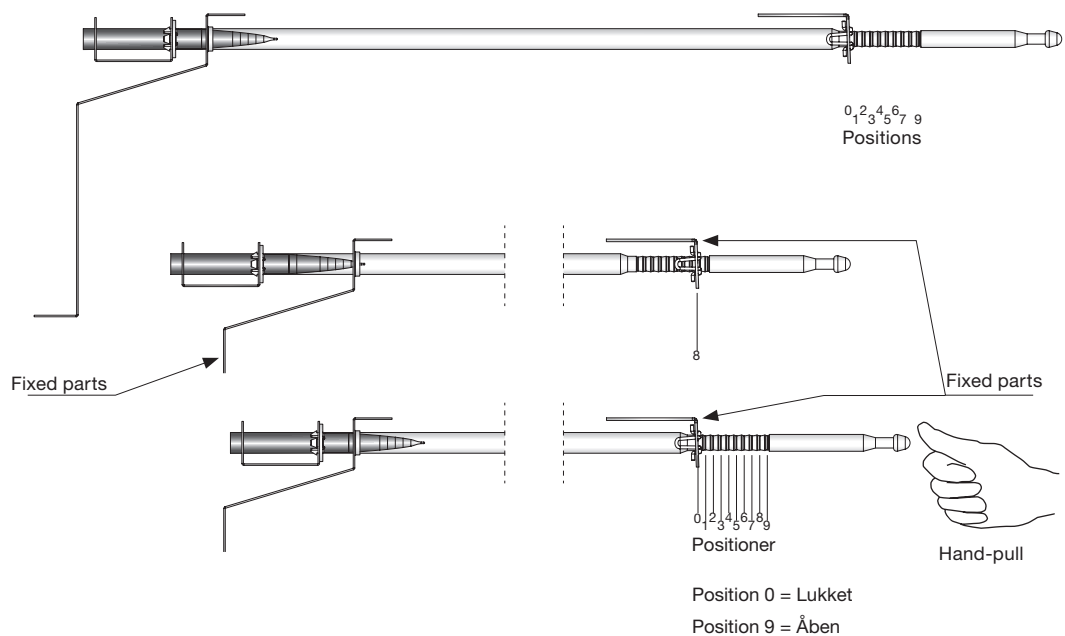
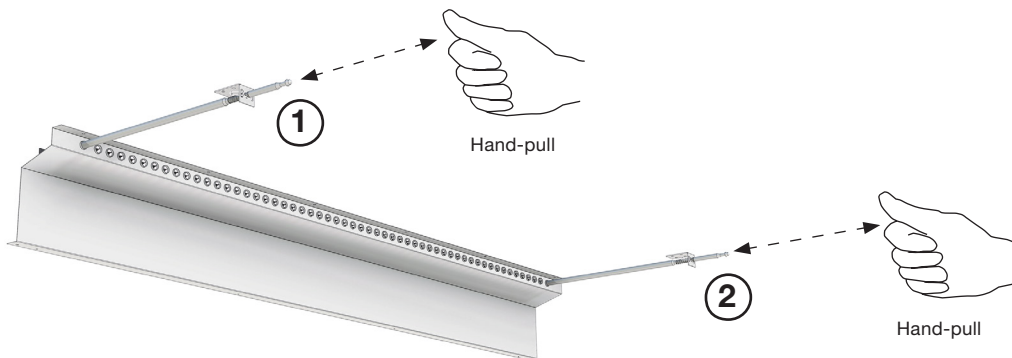
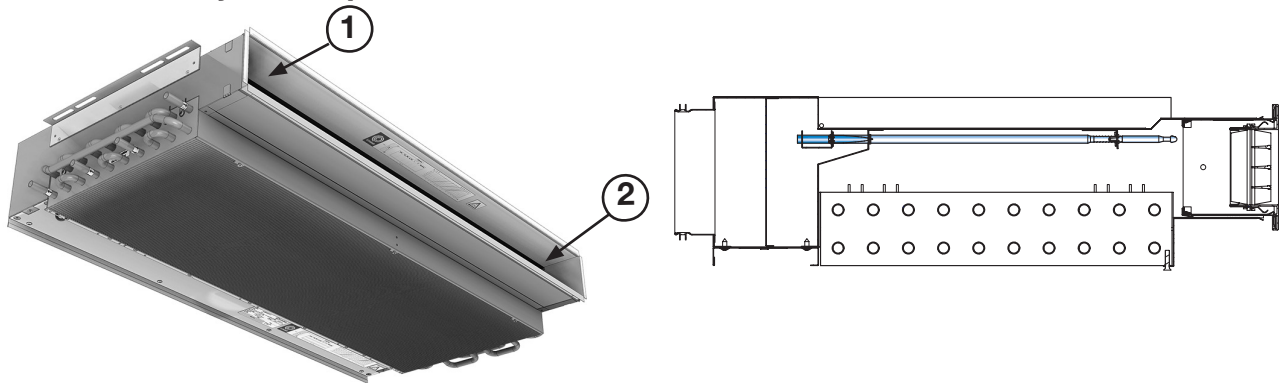

Installation instruction

Munio

6.1.2 Finding values for JetCone pins

Example: **Munio-I-1000-12-125-A6-72-20**

$$\Delta p_{\text{stat}} = 72 \text{ Pa}$$

$$q_a = 20 \text{ l/s}$$

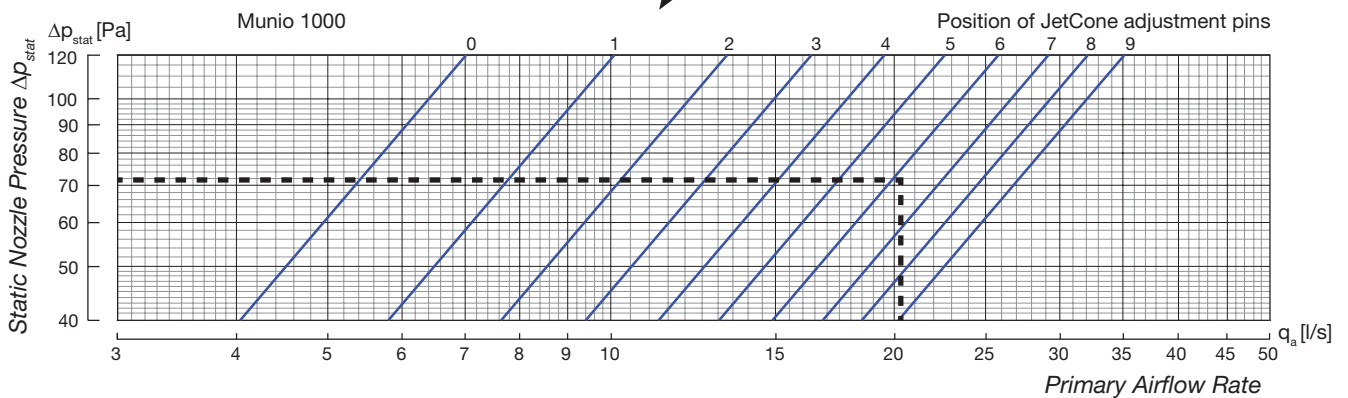
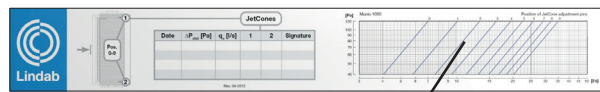
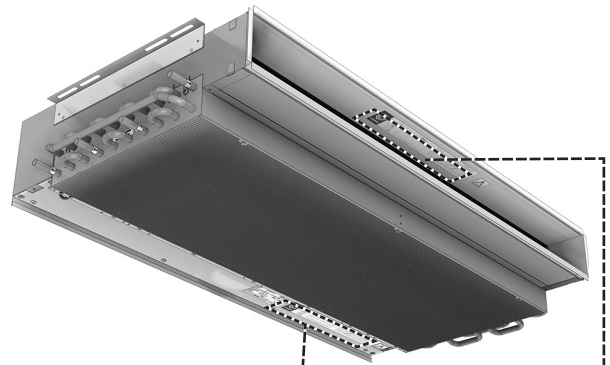

6.1.3 Adjusting air flow and pressure with JetCone pins

Symmetric adjustment

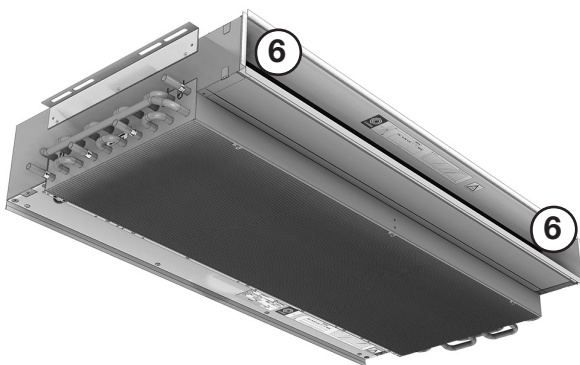

Asymmetric adjustment

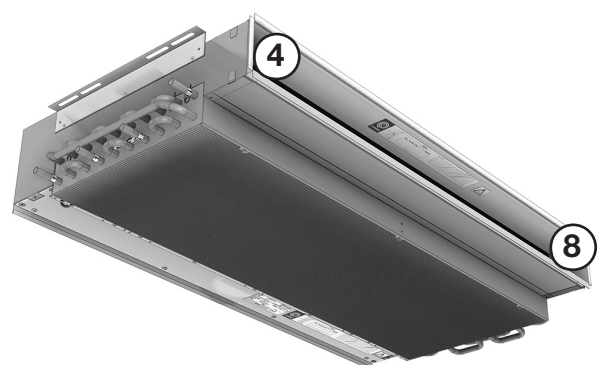

Symmetric adjustment of Jetcones, position 6 read from diagram.

Asymmetric adjustment of Jetcones, position 4 and 8. Keep average value as read in diagram (=6).

Installation instruction

Munio

6.2 Adjustment of air distribution profile

6.2.1 Adjustment of outlet grille vertical directional bars.

AD21CN-M



AL21CN-M



A-A

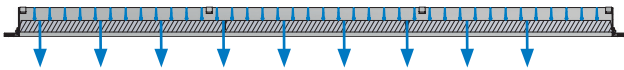

All vertical directional bars in neutral position (0°).

A-A

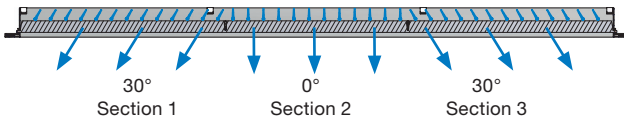

All vertical directional bars in sections (30° - 0° - 30°).

6.2.2 Adjustment of outlet grille horizontal directional bars.

Outlet grille	Vertical adjustment	Horizontal adjustment
AD21CN-M	YES	YES
AL21CN-M	YES	NO

Table 3. Adjustment of outlet grille directional bars.

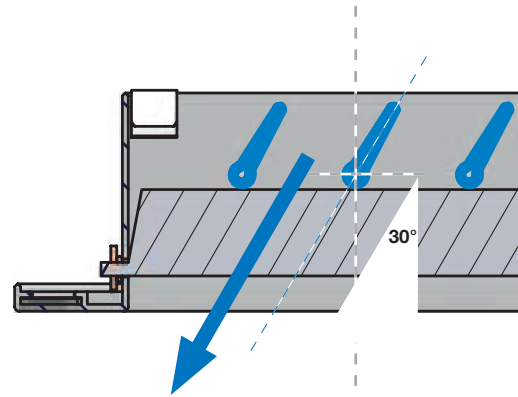

Adjustment of air distribution profile.

Use a triangle or create your own guide for alignment.

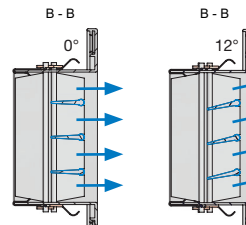

NB! We recommend a maximum horizontal deflection of the front outlet grille AD21CN-M about 15°!

Horizontal directional bars in neutral position (0°) and deflection of 12°.

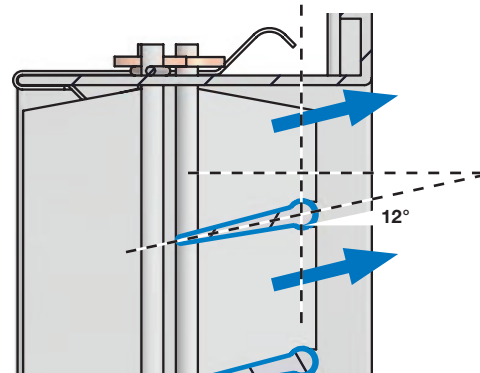

Use a triangle or create your own guide for alignment.

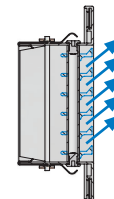

AL21CN-M (15°) with fixed horizontal bars.

Installation instruction

Munio

6.3 Measuring air pressure and calculating the air flow

Before calculating the airflow, the static nozzle pressure must first be measured. The static nozzle pressure is the air pressure available at the nozzles.

6.3.1 Measuring static nozzle pressure and air pressure

- To measure the air pressure, a manometer, (analogue or digital) will be needed. Lindab recommends PC410.
- Insert the measuring tube onto the specialized measuring nozzle.
- Read of the static nozzle pressure from the manometer (PC410).

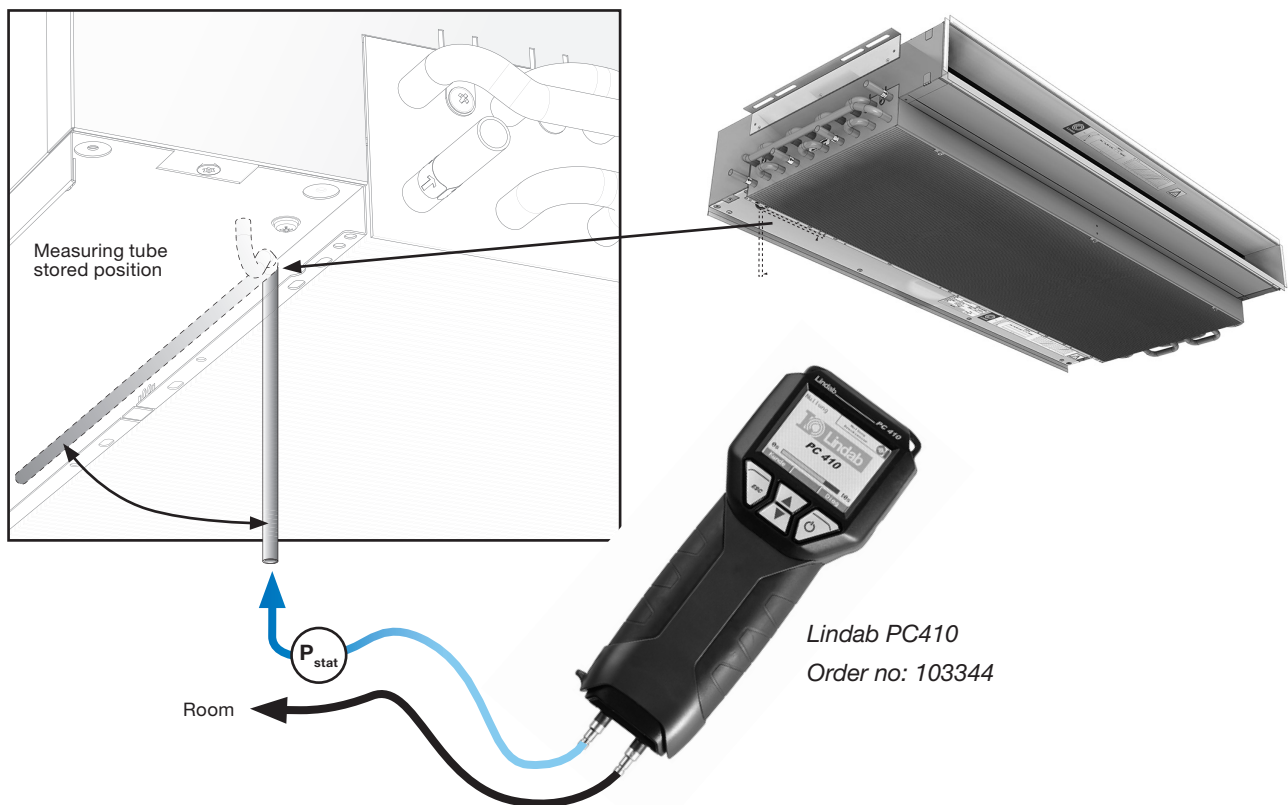

Measuring air flow.

6.3.2 Calculating the actual air flow

- After measuring the static pressure, read the settings of the two JetCone adjustment pins to find the mean value of the pins.
- Locate the diagram inside the telescopic extension piece or on the inspection hatch, (also see next page), and use the static nozzle pressure and the mean value of the pins to find the current airflow.

6.3.3 Changing the actual air flow

- Measure the static nozzle pressure.
- Locate the air pressure/airflow diagram inside the telescopic extension piece or on the inspection hatch. (You can also see diagrams on next page).
- Find the mean value of the 2 pins to reach the desired airflow, in the diagram. Use the static nozzle pressure and the desired airflow to find the mean value of the two pins.
- Adjust the two pins in the Munio, so the mean value of the pins will correspond with the mean value found in the diagram.
- Example: pin setting: $5 + 7 = 12 / 2 = 6$

6.3.4 Changing the air distribution profile

See 6.2

Installation instruction

Munio

6.3.5 Munio pressure / airflow diagrams

Munio 800

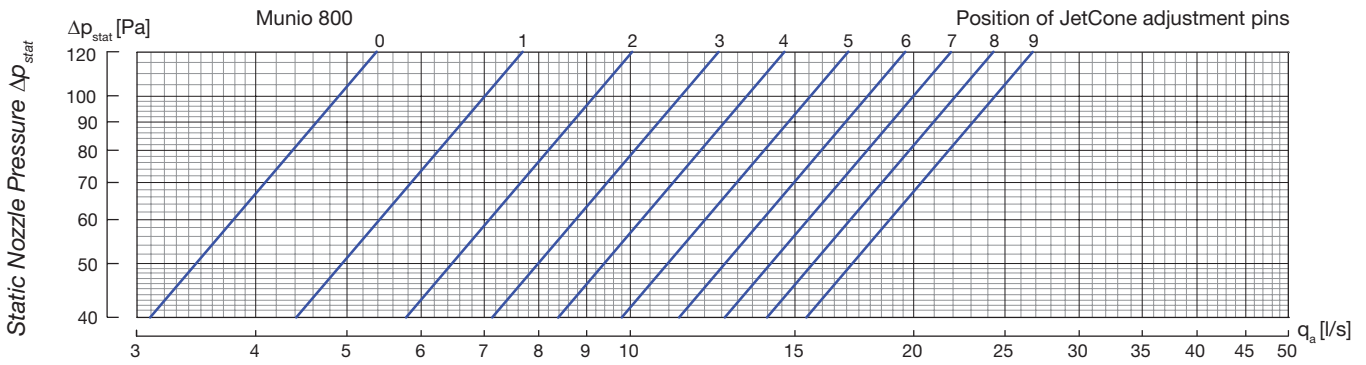

Munio 1000

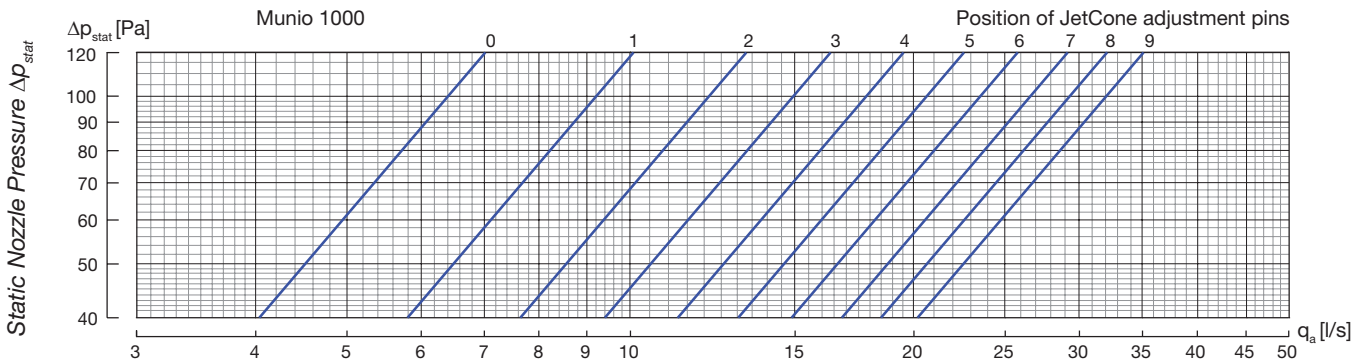

Munio 1200

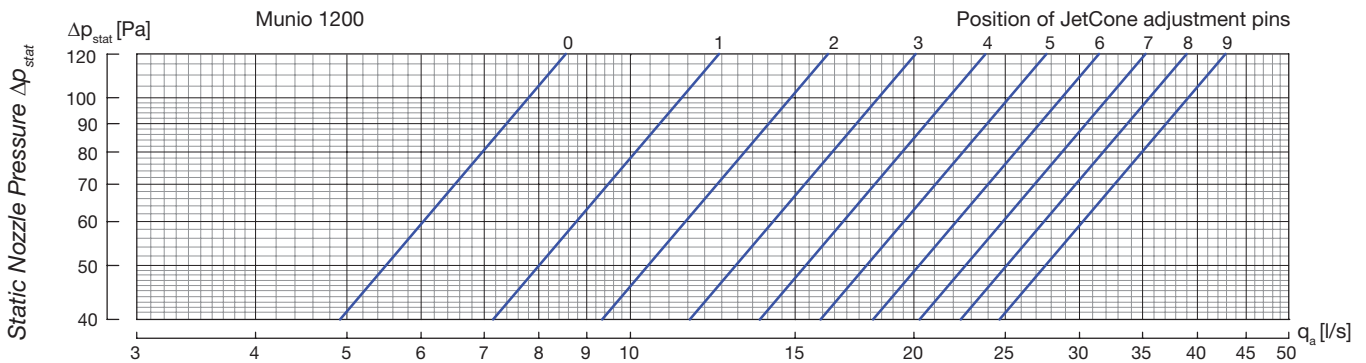

Munio 1400

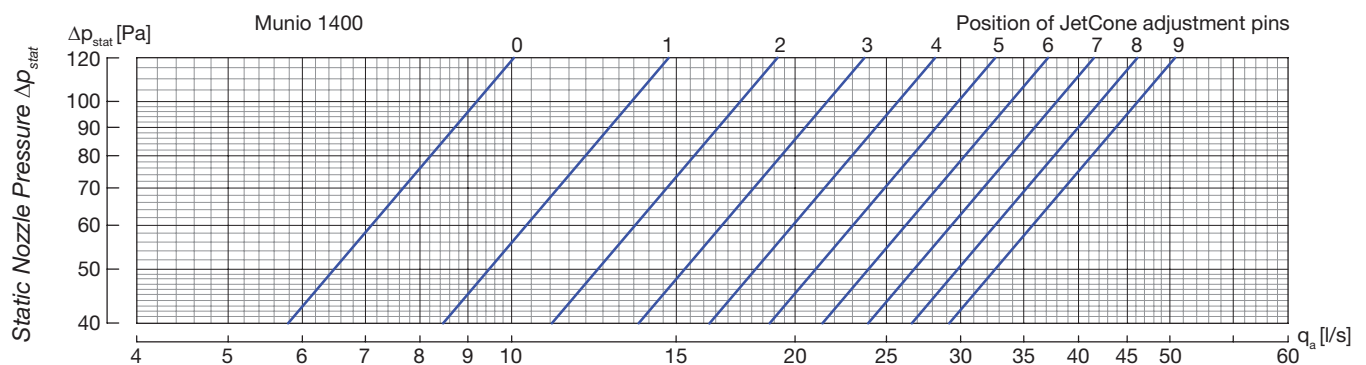

6.4 Water flow rate

6.4.1 Pre-setting of valves

All the integrated control valves (plus feature) are delivered not set. The presetting has to be done on site. For the presetting of valves, please see [LinFlow-A](#) (Angled) and [LinFlow-S](#) (Straight) water valves documentation.

6.4.2 Balancing strategy

Lindab recommends always balancing the water system to guarantee thermal comfort in all areas, to avoid noise nuisance problems and to save energy. A hydraulic balance is obvious to ensure that all the beams (panels or facade units) in the system will always be supplied with their required (planned) water flow rates (calculated with [LindQST waterborne calculator](#)).

Lindab refers to the proportional method, where all beams (panels or facade units) are balanced to the same proportion of the requested water flow rate.

7. Maintenance

The interval of cleaning depends on the indoor environment where the beam is placed. Under optimal conditions the beams only need cleaning every 5 years.

- Remove the outlet front grille (7.1).
- Clean the top side of the battery and the mixing chamber with a vacuum cleaner.
- Open the inlet face plate (7.2).
- Clean the battery downside and the inlet faceplate inner part with a vacuum cleaner.
- Only use lukewarm water and a mild detergent and a piece of wet cloth to clean the inlet face plate and the outlet grille.
- Open the inspection hatch behind the inlet faceplate (7.3).
- Clean the air plenum and air connection with a vacuum cleaner.

7.1 Remove the outlet front grille

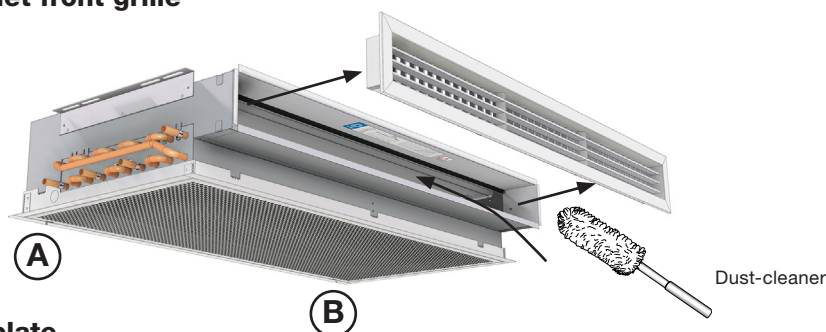

7.2 Open inlet faceplate

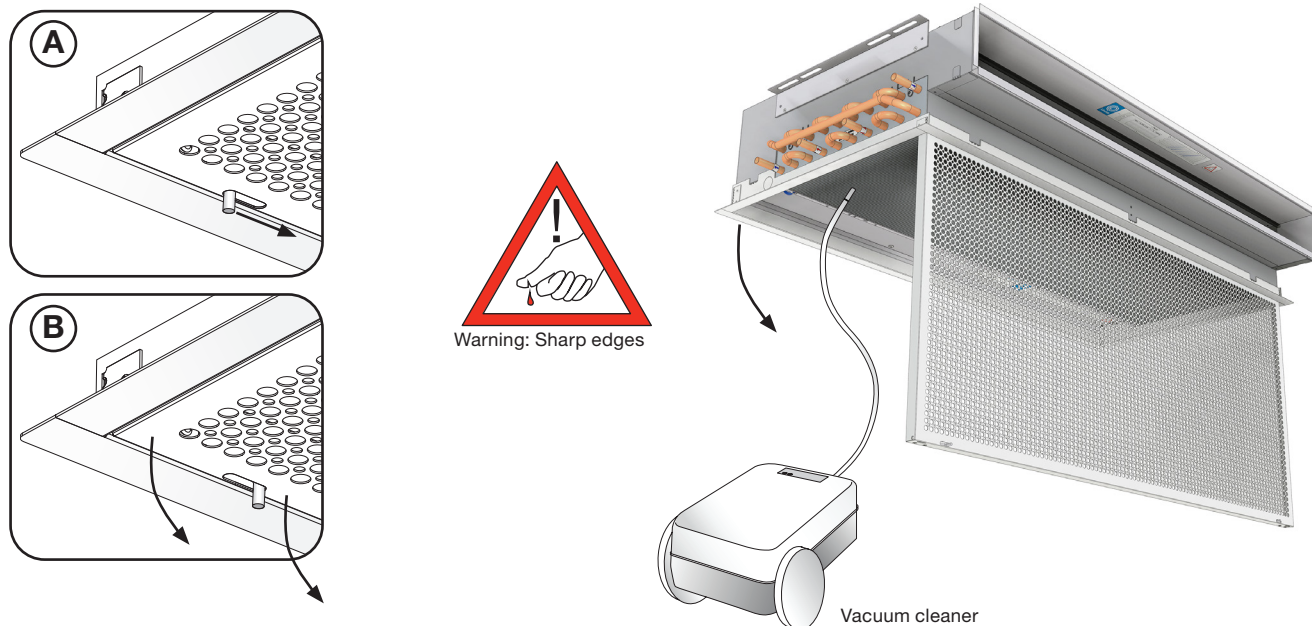

Opening outlet front grille and inlet faceplate.

Installation instruction

Munio

7.3 Opening inspection hatch

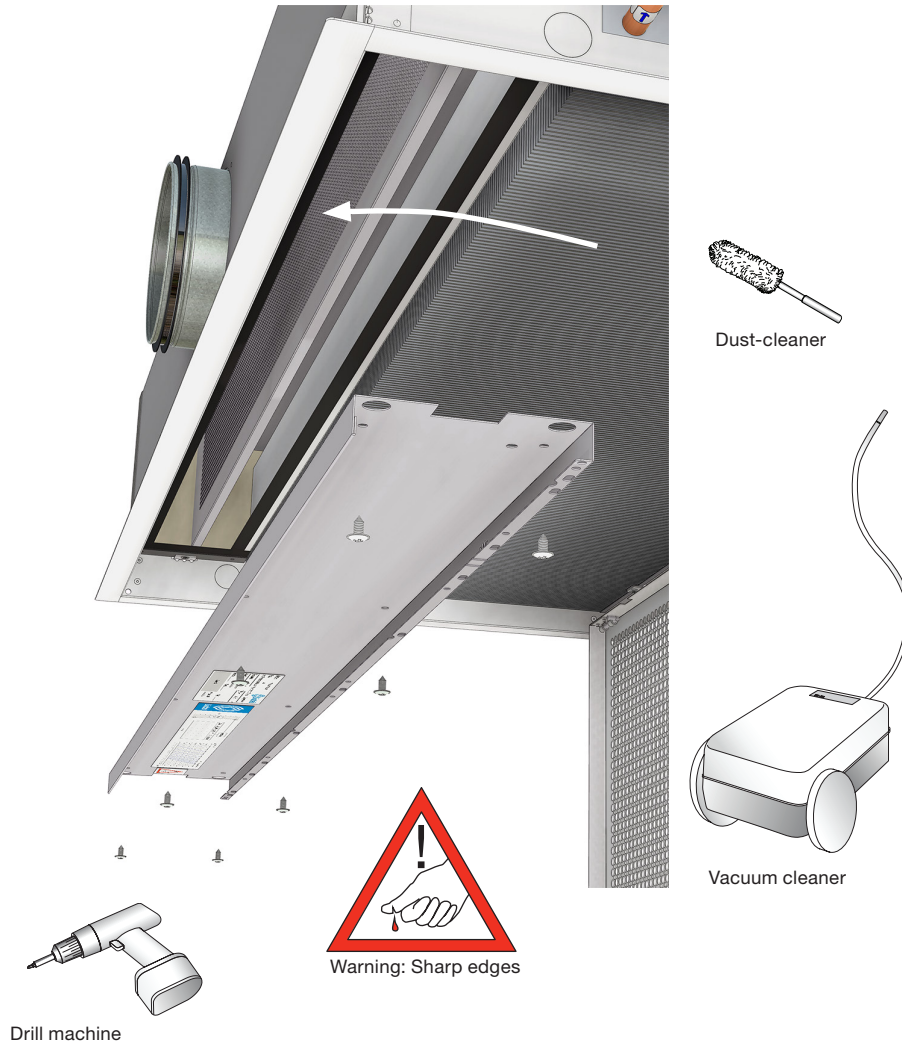

8. Accessories

Ask Lindab for the accessories mentioned in this document. Additional accessories (or additional dimensions) are available on request.**

Order code	Order number
2-way Control valve LinFlow-S-12 straight - push on	686552
2-way Control valve LinFlow-A-12 angled - push on	686554
Actuator A 40405 24 V on/off NC - 1m, non-halogen cable	684601
Actuator A 41405 24 V on/off NO - 1m, non-halogen cable	684603
Actuator APR 40405 0-10 V mod. NC, 1m, non-halogen cable	684667
Actuator APR 40405 0-10 V mod. NC, 1m, cable	684604
AD21CN-M	***
AL21CN-M	***
Ballofix Broen 12mm with handle - shut-off valve	642663
Ballofix Broen 12mm without handle - shut-off valve	642662
Copper insert 12x1,0mm	884022
Flexible hose O2stopp_DN10 0,4m - JG12 push - JG12 push	686566
Flexible hose O2stopp_DN10 0,4m - JG12 push - straight end 12 mm	175984
Lindab PC 410	103344
Pendulum 180-300mm	642480
Pendulum 540-1000mm	646742
Regula Combi see: "Accessories"	**
Regula Connect Card Basic	*/**
Regula Connect Card Multi	*/**
Regula Secura	**
Aerator 12mm - tectite	647690
Tectite angle 12mm	884014
Tectite straight 12mm	884050
Tectite demounting tool 12mm	884087
Tectite demounting tool 12mm small	646881
4 pcs Threaded rod M8 -100mm + 4 pcs z-brackets + 16 pcs screw nuts	on request
Touch-up paint RAL 9003 - 25 ml	174759
Touch-up paint RAL 9010 - 25 ml	642531
Transformer 24V AC output	*/**

Table 4. Accessories.

*see : "[Regula Connect](#) – What do I get?"

**see : "[Accessories](#)"

***see : "[AD21CN-M](#) and [AL21CN-M](#)"



Most of us spend the majority of our time indoors. Indoor climate is crucial to how we feel, how productive we are and if we stay healthy.

We at Lindab have therefore made it our most important objective to contribute to an indoor climate that improves people's lives. We do this by developing energy-efficient ventilation solutions and durable building products. We also aim to contribute to a better climate for our planet by working in a way that is sustainable for both people and the environment.

[Lindab](#) | For a better climate