

Correct wiring

Pascal

LRM/SRM - SRC/ERC

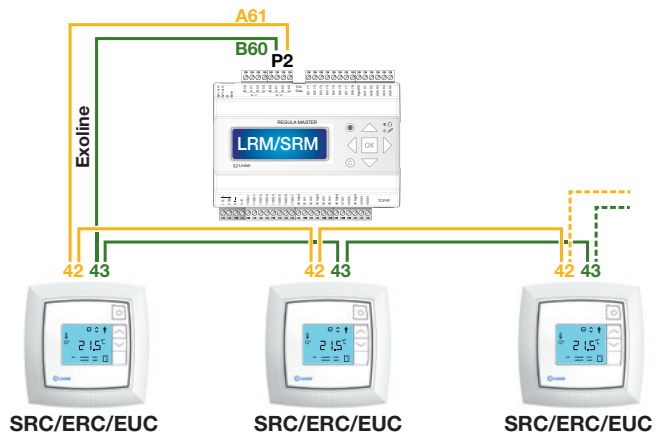

Do not mix A and B. Always use Daisychain connection.

LRM/SRM - Reg. Con. Pascal - SRC/ERC

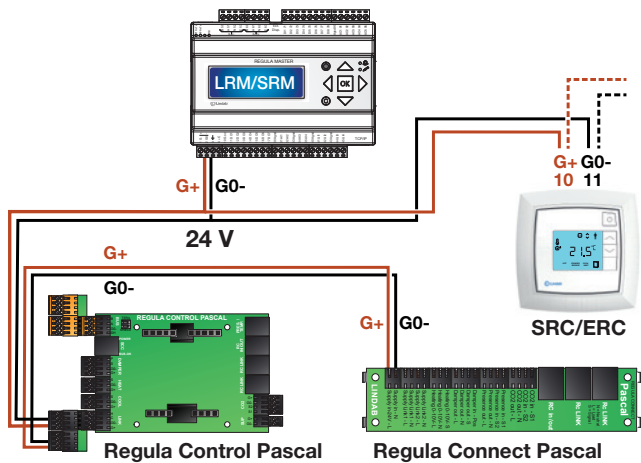

Both star- and chain connection can be used for 24 V power supply. Do not mix G0 and G+!

LRM/SRM - SRC/ERC - Star connection

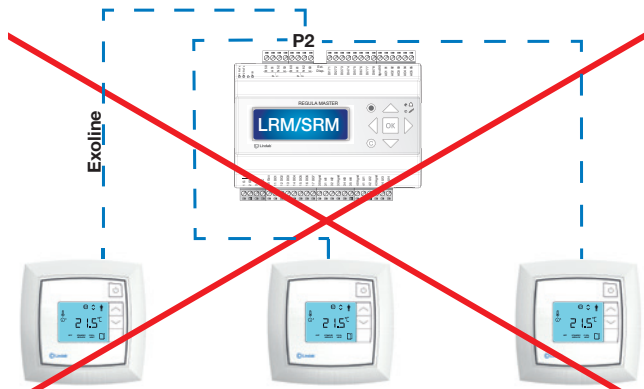

LRM/SRM - Reg. Con. Pascal - SRC/ERC

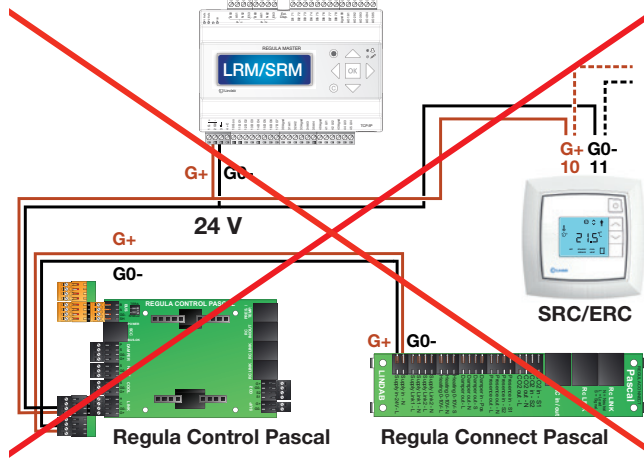

Do not mix G0 and G+!

Correct wiring

Pascal

SRM/SRC/ERC

