

Bend for casting

BUCST



Description

Short installation length with female end and nail flange with pre-punched holes.

Dimensions

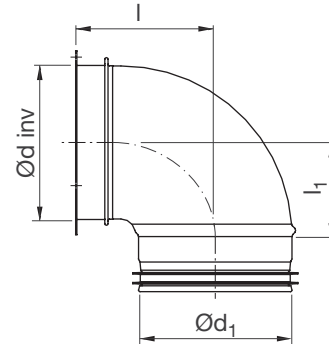

Ød ₁ nom	Ød nom	l [mm]	l ₁ [mm]	m kg
80	80	101	80	0,26
100	100	93	62	0,24
125	125	106	79	0,32
160	160	130	94	0,43

Ordering example

