

Slot diffusers LD-17, LD-18

Application

Slot diffusers LD-17 and LD-18 are designed for supply of cold or warm air in rooms with a height between 2.5 m and 4 m. They allow easy setting of air deflectors for different modes of operation and can be mounted to ceiling or wall.

Description

LD-17 and LD-18 slot diffusers are designed in 1, 2, 3 and 4-slot versions. The unit's front consists of anodised aluminium profiles (on customer's request, these can be powder painted in RAL 9010 or another colour). The individually adjustable air deflectors are made of plastic in white (RAL 9010) or black (RAL 9005) colour). Plenum box is made of galvanised sheet steel. Slot diffusers LD-17 and LD-18 are made in standard lengths: from 200 up to 2000 mm with a 100 mm step (any length available upon request).

Nominal air volume per 1 m of slot:

LD-17 – 150 m³/h

LD-18 – 200 m³/h

($\Delta p_t = 30 \text{ Pa}$, NR = 35 dB)

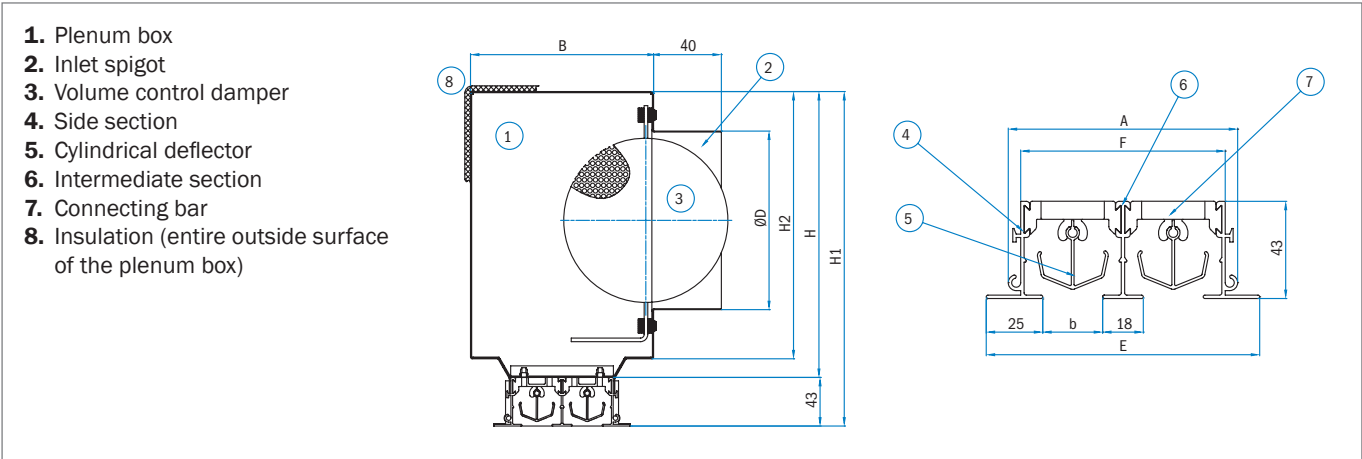

LD-17 b=15

No. of slots	A	F	E	B	H	H1	H2
1	45.5	34.5	65	107	220	263	203.5
2	78.5	67.5	98	139	230	273	213.5
3	111.5	100.5	131	172	250	293	233.5
4	144.5	133.5	164	205	290	333	273.5

LD-18 b=26.5

No. of slots	A	F	E	B	H	H1	H2
1	57.0	46.0	76.5	118	233	276	216.5
2	101.0	90.5	121.0	162	253	296	236.5
3	146.0	135.0	165.5	207	293	336	276.5
4	190.5	179.5	210.0	251	318	361	301.5

VENTILATING GRILLES,
VENTILATING VALVES

CIRCULAR DIFFUSERS,
SQUARE DIFFUSERS

SWIRL DIFFUSERS,
VARIABLE SWIRL
DIFFUSERS

SLOT DIFFUSERS,
ROUND DUCT DIFFUSERS

AIR DISPLACEMENT
UNITS

SUPPLY AIR NOZZLES

EXTERNAL ELEMENTS

AIR FLOW
CONTROL UNITS

SOUND ATTENUATORS,
SOUND ATTENUATING
LOUVERES

Number and diameter of inlet spigots

L	300 to 1000		1100 to 1500		1600 to 2000	
Number of slots	Number and diameter of inlet spigots					
	LD-17	LD-18	LD-17	LD-18	LD-17	LD-18
1	1x98	1x123	2x98	2x123	2x123	2x138
2	1x138	1x158	2x123	2x138	2x138	2x158
3	1x158	1x198	2x138	2x158	2x158	2x198
4	1x198	1x223	2x158	2x198	2x198	2x223

Position of inlet spigots

Number of spigots	Standard length	Position of inlet spigots
1	300-1000	L/2
2	1100-1500	J=300
2	1600-2000	J=400

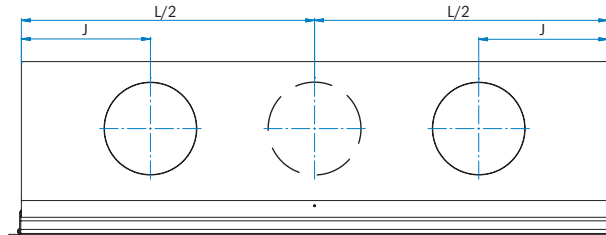

Slot diffuser face plate designs

Slot diffuser face plates are made of linear or angular ended sections, which allow the diffusers to be joined at different angles.

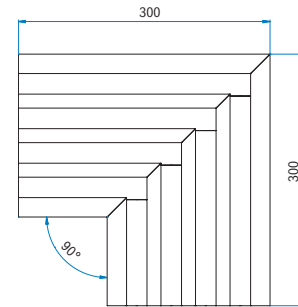
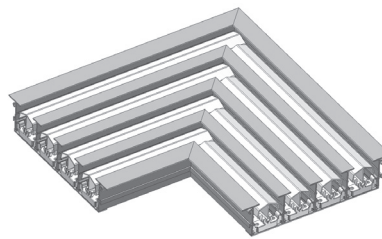

Joining diffusers together in length

Joining in length requires connecting plates (the total length of combined diffusers is not limited).

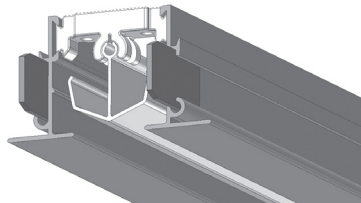

End seals

End seals are components of the diffuser face plate. They are available in two designs:

- as an angle piece (**E** – on both ends, **ET** – on one end only) or
- plates (**F** – on both ends, **FT** – on one end only).

The connecting strip-section has no end anglepieces or plates seals (designation T).

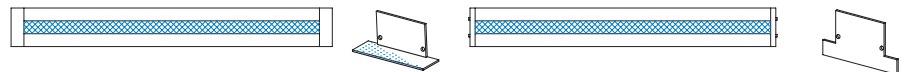

Fixing of the plenum box onto LD-17, LD-18 diffusers

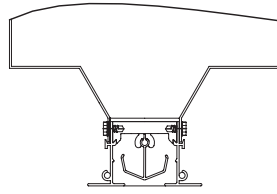

Fixing with self-tapping screws (U)

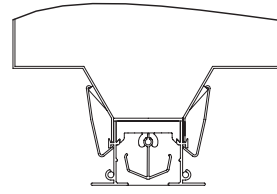

Fixing with spring clamps (S)

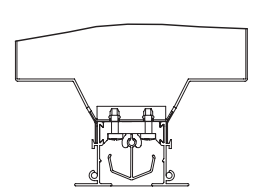

Fixing with a cross-member (Z)

Installation methods

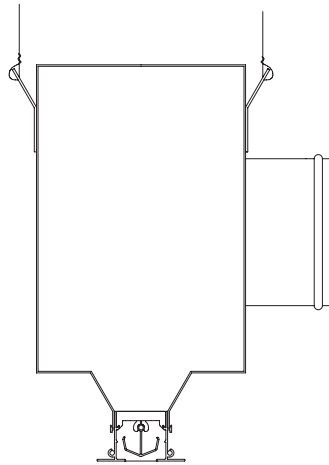

Installation with hangers (P)

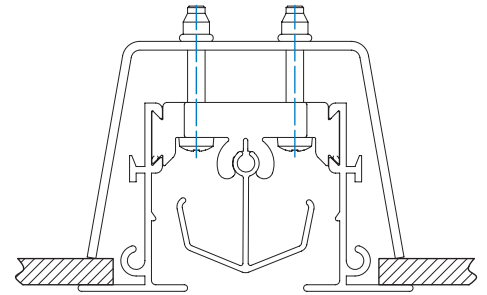

Installation with a cross member without plenum box (N)

Types of air discharges

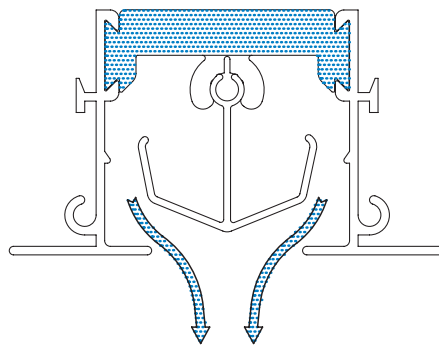

Vertical - heating

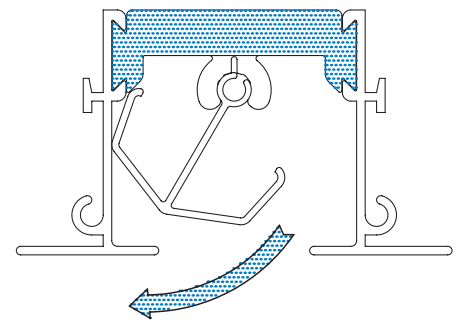

Horizontal - cooling

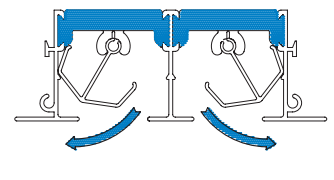
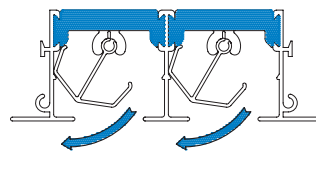
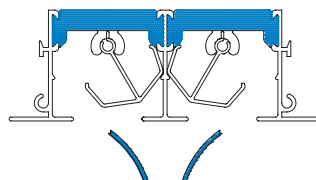
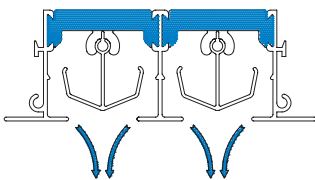

Different settings of the two slot model (similar combinations are possible also for diffusers with more slots).

VENTILATING GRILLES,
VENTILATING VALVES

CIRCULAR DIFFUSERS,
SQUARE DIFFUSERS

SWIRL DIFFUSERS,
VARIABLE SWIRL
DIFFUSERS

SLOT DIFFUSERS,
ROUND DUCT DIFFUSERS

AIR DISPLACEMENT
UNITS

SUPPLY AIR NOZZLES

EXTERNAL ELEMENTS

AIR FLOW
CONTROL UNITS

SOUND ATTENUATORS,
SOUND ATTENUATING
LOUVRES

Ordering key

LD-17/1/B/E/K/M/S/P I5 L=1000 (length L=200, 300, ..., 2000)

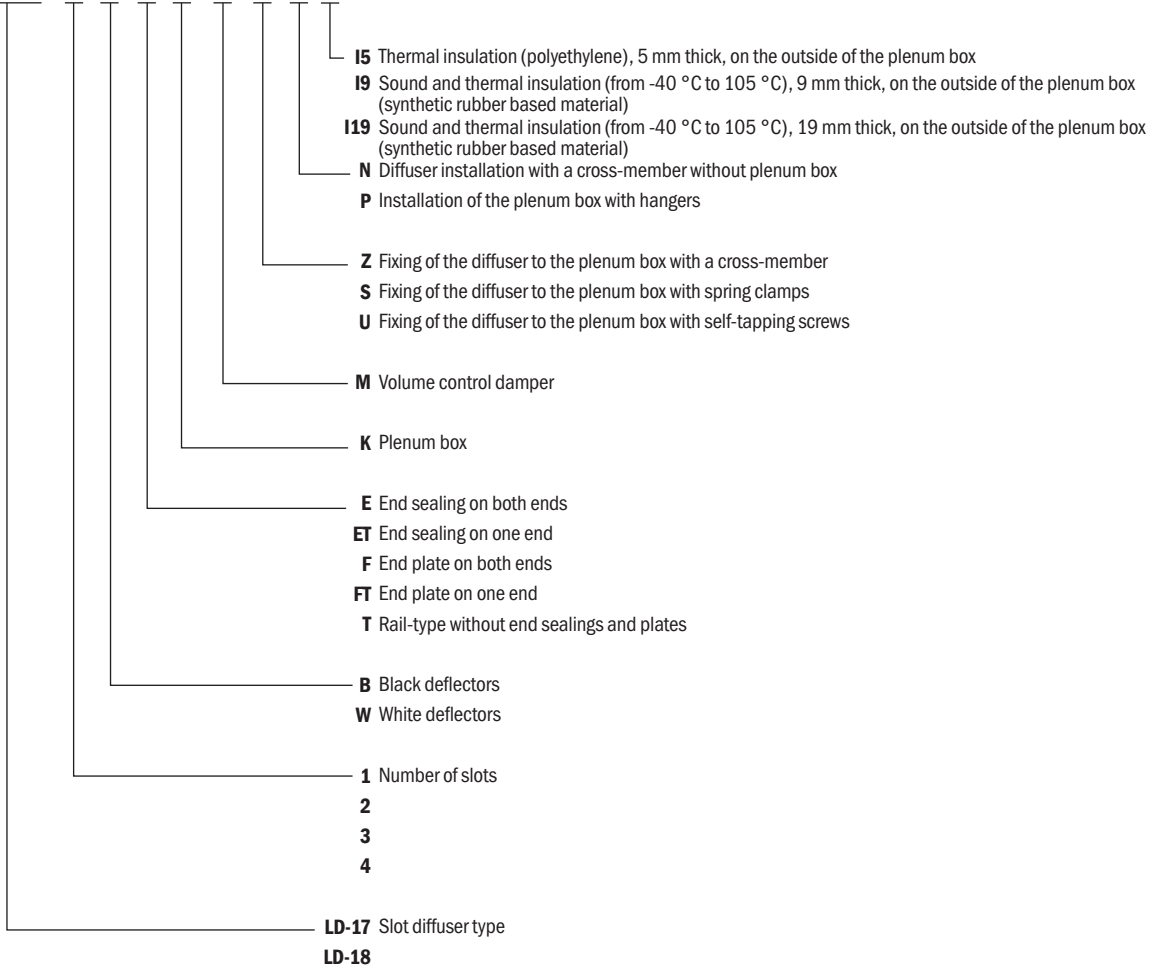

Note:

- Please specify the deflector colour in your order.
- Standard eloxal colour of the aluminium section is the original aluminium colour. Other colours shall be specified in the order.
- When installing in cooling ceilings, consult the manufacturer.
- Versions with insulation on the inside of the plenum box are also available.

Quick selection diagram: $L_{WA} < 35$ dB(A)

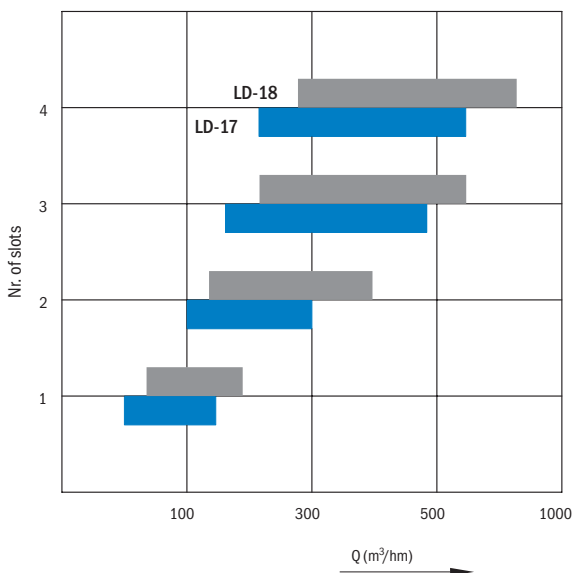

Sound power level, pressure drop and throw distances
LD-17 horizontal discharge

Type	Q	[l/s]	13.9	27.8	41.7	55.6	83.3	111.1	138.9	166.7	194.4	222.2	250.0	277.8	333.3
		[m ² /h]	50	100	150	200	300	400	500	600	700	800	900	1000	1200
LD-17/1 L=500 mm	L _{WA}	[dB (A)]	32	47											
	Δp _t	[Pa]	13	42											
	L _{0.2}	[m]	5.6	6.6											
	L _{min}	[m]	12.5	>15											
LD-17/1 L=1000 mm	L _{WA}	[dB (A)]	27	35	43	50									
	Δp _t	[Pa]	8	27	56	95									
	L _{0.2}	[m]	6	6.5	6.7	6.8									
	L _{min}	[m]	12	>15	>15	>15									
LD-17/1 L=1500 mm	L _{WA}	[dB (A)]	<25	29	34	40	50								
	Δp _t	[Pa]	5	16	32	52	99								
	L _{0.2}	[m]	5.5	6.1	6.5	6.6	6.8								
	L _{min}	[m]	4	12.5	>15	>15	>15								
LD-17/1 L=2000 mm	L _{WA}	[dB (A)]		<25	32	36	43	49							
	Δp _t	[Pa]		2	3	6	11	19							
	L _{0.2}	[m]		5.8	6.1	6.5	6.7	6.8							
	L _{min}	[m]		6.5	12.5	13	>15	>15							
LD-17/2 L=500 mm	L _{WA}	[dB (A)]	<25	34	42	50									
	Δp _t	[Pa]	3	11	22	36									
	L _{0.2}	[m]	5	5.4	5.7	5.8									
	L _{min}	[m]	11.5	14	>15	>15									
LD-17/2 L=1000 mm	L _{WA}	[dB (A)]		27	30	36	45	50							
	Δp _t	[Pa]		7	14	22	48	80							
	L _{0.2}	[m]		5.3	5.4	5.5	5.7	5.8							
	L _{min}	[m]		8	13.2	13.4	>15	>15							
LD-17/2 L=1500 mm	L _{WA}	[dB (A)]			26	30	36	42	46	52					
	Δp _t	[Pa]			8	13	28	44	65	84					
	L _{0.2}	[m]			5.1	5.4	5.5	5.6	5.8	5.8					
	L _{min}	[m]			5.7	13.3	13.5	>15	>15	>15					
LD-17/2 L=2000 mm	L _{WA}	[dB (A)]				26	32	36	41	44	48	51			
	Δp _t	[Pa]				2	4	7	10	13	18	22			
	L _{0.2}	[m]				5.2	5.4	5.5	5.6	5.7	5.7	5.8			
	L _{min}	[m]				7.5	13.2	13.4	>15	>15	>15	>15			
LD-17/3 L=500 mm	L _{WA}	[dB (A)]		30	37	45	54								
	Δp _t	[Pa]		5	12	20	50								
	L _{0.2}	[m]		8	8.5	8.7	9								
	L _{min}	[m]		9	10.5	11.2	13.5								
LD-17/3 L=1000 mm	L _{WA}	[dB (A)]		<25	29	34	42	50							
	Δp _t	[Pa]		3	8	14	32	54							
	L _{0.2}	[m]		7.7	7.9	8	8.5	8.8							
	L _{min}	[m]		6.4	6.9	9	11	12							
LD-17/3 L=1500 mm	L _{WA}	[dB (A)]				28	35	42	48	53					
	Δp _t	[Pa]				8	19	34	52	79					
	L _{0.2}	[m]				7.8	8.2	8.5	8.7	8.7					
	L _{min}	[m]				7.5	9.5	10.8	11.7	12.3					
LD-17/3 L=2000 mm	L _{WA}	[dB (A)]					31	36	41	46	50	54			
	Δp _t	[Pa]					2	4	6	8	12	17			
	L _{0.2}	[m]					7.9	8.1	8.4	8.5	8.6	9			
	L _{min}	[m]					7.7	9.6	10.5	11	11.9	12			

 VENTILATING GRILLES,
VENTILATING VALVES

 CIRCULAR DIFFUSERS,
SQUARE DIFFUSERS

 SWIRL DIFFUSERS,
VARIABLE SWIRL
DIFFUSERS

 SLOT DIFFUSERS,
ROUND DUCT DIFFUSERS

 AIR DISPLACEMENT
UNITS

SUPPLY AIR NOZZLES

EXTERNAL ELEMENTS

 AIR FLOW
CONTROL UNITS

 SOUND ATTENUATORS,
SOUND ATTENUATING
LOUVERES

Type	Q	[l/s]	13.9	27.8	41.7	55.6	83.3	111.1	138.9	166.7	194.4	222.2	250.0	277.8	333.3
		[m³/h]	50	100	150	200	300	400	500	600	700	800	900	1000	1200
LD-17/4 L=500 mm	L _{WA}	[dB (A)]		25	32	40	51	55							
	Δp _t	[Pa]		3	7	12	29	50							
	L _{0.2}	[m]		7.2	7.5	7.6	8	8.1							
	L _{min}	[m]		8.2	9	9.5	10.5	11.2							
LD-17/4 L=1000 mm	L _{WA}	[dB (A)]				35	38	46	53	60					
	Δp _t	[Pa]				9	21	38	56	90					
	L _{0.2}	[m]				7.5	7.6	7.7	7.9	8					
	L _{min}	[m]				8.3	9	9.5	10.5	10.5					
LD-17/4 L=1500 mm	L _{WA}	[dB (A)]					32	38	44	48	52	60			
	Δp _t	[Pa]					10	19	30	44	60	80			
	L _{0.2}	[m]					7.2	7.5	7.6	7.8	7.9	8			
	L _{min}	[m]					7.5	8.7	9.5	9.8	10.2	10.4			
LD-17/4 L=2000 mm	L _{WA}	[dB (A)]						34	38	42	45	49	52	56	60
	Δp _t	[Pa]						3	5	7	9	12	17	23	33
	L _{0.2}	[m]						7.4	7.5	7.6	7.8	7.8	7.8	7.9	8.3
	L _{min}	[m]						8.2	8.6	9.2	9.5	9.7	10.2	10.5	11.3

Definition of symbols

- L_{WA} A-weighted sound power level
- Δp_t Total pressure drop calculated to normal conditions
- L_{0.2} Isothermal throw distance of supply air jet, when its velocity drops down to 0.2 m/s
- L_{min} Minimum distance between diffusers, that the jet velocity is less than or equal to 0.2 m/s

Conditions for L_{min}:

- Q=600 m³/h
- L=1000 mm
- Room height: H=2.8 m
- Occupied zone height: 1.8 m
- Room temperature: 24 °C
- Supply temperature: ΔT= -6 K

Sound power level, pressure drop and throw distances

LD-17 vertical discharge

Type	Q	[l/s]	13.9	27.8	41.7	55.6	83.3	111.1	138.9	166.7	194.4	222.2	250.0	277.8	333.3
		[m³/h]	50	100	150	200	300	400	500	600	700	800	900	1000	1200
LD-17/1 L=500 mm	L _{WA}	[dB (A)]	32	47											
	Δp _t	[Pa]	17	68											
	L _{0.2} (+10K)	[m]	2.4	4.8											
LD-17/1 L=1000 mm	L _{WA}	[dB (A)]	27	35	43	50									
	Δp _t	[Pa]	4	17	39	68									
	L _{0.2} (+10K)	[m]	1	2.4	3.5	5									
LD-17/1 L=1500 mm	L _{WA}	[dB (A)]	<25	29	34	40	50								
	Δp _t	[Pa]	2	8	17	30	68								
	L _{0.2} (+10K)	[m]	0.9	1.5	2.3	3.3	4.7								
LD-17/1 L=2000 mm	L _{WA}	[dB (A)]		<25	32	36	43	49							
	Δp _t	[Pa]		4	10	17	39	68							
	L _{0.2} (+10K)	[m]		0.8	1.8	2.4	3.8	4.8							
LD-17/2 L=500 mm	L _{WA}	[dB (A)]	25	35	43	51									
	Δp _t	[Pa]	4	17	39	68									
	L _{0.2} (+10K)	[m]	1.6	3	4	4.5									
LD-17/2 L=1000 mm	L _{WA}	[dB (A)]		28	31	37	46	51							
	Δp _t	[Pa]		4	10	17	39	68							
	L _{0.2} (+10K)	[m]		1.6	2.6	3	4.2	4.5							

Type	Q	[l/s]	13.9	27.8	41.7	55.6	83.3	111.1	138.9	166.7	194.4	222.2	250.0	277.8	333.3
		[m ² /h]	50	100	150	200	300	400	500	600	700	800	900	1000	1200
LD-17/2 L=1500 mm	L _{WA}	[dB (A)]			26	30	36	42	46	52					
	Δp _t	[Pa]			4	8	17	30	48	68					
	L _{0,2} (+10K)	[m]			1.6	2.5	3.2	3.6	4	4.5					
LD-17/2 L=2000 mm	L _{WA}	[dB (A)]				26	32	36	41	44	48	51			
	Δp _t	[Pa]				4	10	17	27	39	52	68			
	L _{0,2} (+10K)	[m]				1.8	2.5	3.1	3.5	3.8	4.3	4.5			
LD-17/3 L=500 mm	L _{WA}	[dB (A)]		31	38	46	55								
	Δp _t	[Pa]		8	17	30	68								
	L _{0,2} (+10K)	[m]		3.1	4.2	5.5	7.5								
LD-17/3 L=1000 mm	L _{WA}	[dB (A)]			31	36	44	52							
	Δp _t	[Pa]			4	8	17	30							
	L _{0,2} (+10K)	[m]			1.9	3.1	4.2	5.5							
LD-17/3 L=1500 mm	L _{WA}	[dB (A)]				30	37	44	50	55					
	Δp _t	[Pa]				3	8	14	21	30					
	L _{0,2} (+10K)	[m]				1.5	2.9	3.8	4.8	5.5					
LD-17/3 L=2000 mm	L _{WA}	[dB (A)]					32	37	42	47	51	55			
	Δp _t	[Pa]					4	8	12	17	23	30			
	L _{0,2} (+10K)	[m]					1.9	3.1	3.8	4.3	5	5.5			
LD-17/4 L=500 mm	L _{WA}	[dB (A)]		27	34	42	53	57							
	Δp _t	[Pa]		4	10	17	39	68							
	L _{0,2} (+10K)	[m]		3.1	4.3	5.2	6.8	7.7							
LD-17/4 L=1000 mm	L _{WA}	[dB (A)]				36	39	47	54	61					
	Δp _t	[Pa]				4	10	17	27	39					
	L _{0,2} (+10K)	[m]				3	4.4	5.2	6.1	6.7					
LD-17/4 L=1500 mm	L _{WA}	[dB (A)]					33	39	45	49	53	61			
	Δp _t	[Pa]					4	8	12	17	23	30			
	L _{0,2} (+10K)	[m]					2.9	4.1	4.8	5.2	5.8	6.2			
LD-17/4 L=2000 mm	L _{WA}	[dB (A)]						35	39	43	46	50	53	57	61
	Δp _t	[Pa]						4	7	10	13	17	22	27	39
	L _{0,2} (+10K)	[m]						3.1	4	4.3	4.8	5.3	5.8	6.1	6.8

Definition of symbols

L _{WA}	A-weighted sound power level
Δp _t	Total pressure drop calculated to normal conditions
L _{0,2} (+10 °C)	Isothermal throw distance of supply air jet with temperature +10K, when its velocity drops down to 0.2 m/s

 VENTILATING GRILLES,
VENTILATING VALVES

 CIRCULAR DIFFUSERS,
SQUARE DIFFUSERS

 SWIRL DIFFUSERS,
VARIABLE SWIRL
DIFFUSERS

 SLOT DIFFUSERS,
ROUND DUCT DIFFUSERS

 AIR DISPLACEMENT
UNITS

SUPPLY AIR NOZZLES

EXTERNAL ELEMENTS

 AIR FLOW
CONTROL UNITS

 SOUND ATTENUATORS,
SOUND ATTENUATING
LOUVRES

Sound power level, pressure drop and throw distances

LD-18 horizontal discharge

Type	Q	[l/s]	27.8	41.7	55.6	83.3	111.1	138.9	166.7	194.4	222.2	250.0	277.8	333.3	388.9
		[m³/h]	100	150	200	300	400	500	600	700	800	900	1000	1200	1400
LD-18/1 L=500 mm	L _{WA}	[dB (A)]	41	51											
	Δp _t	[Pa]	24	53											
	L _{0.2}	[m]	6.6	6.9											
	L _{min}	[m]	>15	>15											
LD-18/1 L=1000 mm	L _{WA}	[dB (A)]	29	37	44										
	Δp _t	[Pa]	16	36	64										
	L _{0.2}	[m]	6.2	6.5	6.7										
	L _{min}	[m]	12.8	>15	>15										
LD-18/1 L=1500 mm	L _{WA}	[dB (A)]	25	31	36	46									
	Δp _t	[Pa]	9	19	34	77									
	L _{0.2}	[m]	5.8	6.2	6.4	6.6									
	L _{min}	[m]	4.2	12.8	>15	>15									
LD-18/1 L=2000 mm	L _{WA}	[dB (A)]	<25	28	32	40	47	53	58	62					
	Δp _t	[Pa]	1	2	4	9	15	24	35	47					
	L _{0.2}	[m]	5.2	5.9	6.2	6.5	6.7	6.8	6.9	6.9					
	L _{min}	[m]	2	6.6	12.8	>15	>15	>15	>15	>15					
LD-18/2 L=500 mm	L _{WA}	[dB (A)]	29	37	45	56									
	Δp _t	[Pa]	6	13	24	53									
	L _{0.2}	[m]	5.4	5.6	5.7	5.8									
	L _{min}	[m]	14	>15	>15	>15									
LD-18/2 L=1000 mm	L _{WA}	[dB (A)]	<25	27	32	40	48								
	Δp _t	[Pa]	4	9	16	37	65								
	L _{0.2}	[m]	5	5.3	5.5	5.6	5.7								
	L _{min}	[m]	2	8	13.4	>15	>15								
LD-18/2 L=1500 mm	L _{WA}	[dB (A)]		<25	27	34	40	45	50						
	Δp _t	[Pa]		5	9	20	35	55	80						
	L _{0.2}	[m]		5	5.2	5.4	5.6	5.7	5.7						
	L _{min}	[m]		2	5.8	13.4	>15	>15	>15						
LD-18/2 L=2000 mm	L _{WA}	[dB (A)]			25	30	35	39	44	47	51	54	57	62	67
	Δp _t	[Pa]			1	3	6	9	13	18	23	29	36	52	71
	L _{0.2}	[m]			5	5.3	5.4	5.5	5.6	5.7	5.7	5.7	5.8	5.8	5.8
	L _{min}	[m]			2	8	13.4	>15	>15	>15	>15	>15	>15	>15	>15
LD-18/3 L=500 mm	L _{WA}	[dB (A)]	<25	31	37	48	56	63							
	Δp _t	[Pa]	3	6	11	24	42	66							
	L _{0.2}	[m]	8	8.3	8.6	8.8	9	9.1							
	L _{min}	[m]	8	10	11.2	12.6	13.4	13.8							
LD-18/3 L=1000 mm	L _{WA}	[dB (A)]		<25	27	34	40	46	51	55					
	Δp _t	[Pa]		4	7	16	29	45	65	88					
	L _{0.2}	[m]		7.7	8	8.3	8.6	8.7	8.8	8.9					
	L _{min}	[m]		6.4	8	10	11.2	12	12.6	13					
LD-18/3 L=1500 mm	L _{WA}	[dB (A)]			<25	29	34	38	42	46	50	53	56		
	Δp _t	[Pa]			4	9	15	24	34	47	61	77	96		
	L _{0.2}	[m]			7.6	8	8.2	8.4	8.6	8.7	8.7	8.8	8.9		
	L _{min}	[m]			5.8	8.2	9.6	10.6	11.2	11.8	12.2	12.6	12.8		
LD-18/3 L=2000 mm	L _{WA}	[dB (A)]				26	30	34	37	40	44	46	49	54	58
	Δp _t	[Pa]				1	2	3	4	6	8	10	12	17	23
	L _{0.2}	[m]				7.7	8	8.2	8.4	8.5	8.6	8.6	8.7	8.8	8.9
	L _{min}	[m]				6.4	8	9.2	10	10.8	11.2	11.8	12	12.6	13

Type	Q	[l/s]	27.8	41.7	55.6	83.3	111.1	138.9	166.7	194.4	222.2	250.0	277.8	333.3	388.9
		[m ³ /h]	100	150	200	300	400	500	600	700	800	900	1000	1200	1400
LD-18/4 L=500 mm	L _{WA}	[dB (A)]		28	34	44	52	58	64	68					
	Δp _t	[Pa]		3	6	13	24	37	53	72					
	L _{0.2}	[m]		7.4	7.6	7.8	8	8.1	8.2	8.3					
	L _{min}	[m]		8.2	9	10.2	10.6	11	11.2	11.4					
LD-18/4 L=1000 mm	L _{WA}	[dB (A)]			<25	31	37	42	47	51	55	58			
	Δp _t	[Pa]			4	9	16	26	37	50	65	83			
	L _{0.2}	[m]			7	7.4	7.6	7.7	7.8	7.9	8	8			
	L _{min}	[m]			6.2	8.2	9	9.6	10.2	10.4	10.6	10.8			
LD-18/4 L=1500 mm	L _{WA}	[dB (A)]				26	31	35	38	42	45	48	51	56	
	Δp _t	[Pa]				5	9	14	20	28	36	46	57	82	
	L _{0.2}	[m]				7	7.3	7.4	7.6	7.7	7.8	7.8	7.9	8	
	L _{min}	[m]				6.2	7.6	8.4	9	9.6	9.8	10	10.4	10.6	
LD-18/4 L=2000 mm	L _{WA}	[dB (A)]					28	31	34	37	40	42	45	50	54
	Δp _t	[Pa]					2	3	4	6	7	9	11	16	22
	L _{0.2}	[m]					7	7.2	7.4	7.5	7.6	7.7	7.7	7.8	7.9
	L _{min}	[m]					6.2	7.4	8.2	8.6	9.2	9.4	9.8	10.2	10.4

Definition of symbols

L _{WA}	A-weighted sound power level
Δp _t	Total pressure drop calculated to normal conditions
L _{0.2}	Isothermal throw distance of supply air jet, when its velocity drops down to 0.2 m/s
L _{min}	Minimum distance between diffusers, that the jet velocity is less than or equal to 0.2 m/s

Conditions for L_{min}:

Q=600 m ³ /h	
L=1000 mm	
Room height:	H=2.8 m
Occupied zone height:	1.8 m
Room temperature:	24 °C
Supply temperature:	ΔT= -6 K

Sound power level, pressure drop and throw distances

LD-18 vertical discharge

Type	Q	[l/s]	27.8	41.7	55.6	83.3	111.1	138.9	166.7	194.4	222.2	250.0	277.8	333.3	388.9
		[m ³ /h]	100	150	200	300	400	500	600	700	800	900	1000	1200	1400
LD-18/1 L=500 mm	L _{WA}	[dB (A)]	40	51											
	Δp _t	[Pa]	25	56											
	L _{0.2} (+10K)	[m]	3.4	5.1											
LD-18/1 L=1000 mm	L _{WA}	[dB (A)]	29	36	43										
	Δp _t	[Pa]	17	39	69										
	L _{0.2} (+10K)	[m]	1.5	2.5	3.4										
LD-18/1 L=1500 mm	L _{WA}	[dB (A)]	25	31	36	45									
	Δp _t	[Pa]	10	21	38	86									
	L _{0.2} (+10K)	[m]	0.7	1.5	2.2	3.5									
LD-18/1 L=2000 mm	L _{WA}	[dB (A)]		28	32	39	46	52	57						
	Δp _t	[Pa]		4	7	17	30	47	67						
	L _{0.2} (+10K)	[m]		0.9	2	2.5	3.5	4.4	5.2						
LD-18/2 L=500 mm	L _{WA}	[dB (A)]	29	37	44	55									
	Δp _t	[Pa]	6	14	25	56									
	L _{0.2} (+10K)	[m]	2.4	3.2	3.8	4.6									
LD-18/2 L=1000 mm	L _{WA}	[dB (A)]	<25	27	32	40	47								
	Δp _t	[Pa]	4	10	17	39	69								
	L _{0.2} (+10K)	[m]	1	1.9	2.4	3.2	3.8								
LD-18/2 L=1500 mm	L _{WA}	[dB (A)]		<25	27	33	39	44	49						
	Δp _t	[Pa]		6	10	22	39	61	88						
	L _{0.2} (+10K)	[m]		1.1	1.7	2.4	3	3.4	3.8						
LD-18/2 L=2000 mm	L _{WA}	[dB (A)]			25	30	35	39	43	47	50	53	56	61	
	Δp _t	[Pa]			2	5	9	15	21	29	38	48	59	85	
	L _{0.2} (+10K)	[m]			1	1.9	2.4	2.9	3.2	3.5	3.8	4	4.3	4.6	
LD-18/3 L=500 mm	L _{WA}	[dB (A)]	23	30	36	46	54	60							
	Δp _t	[Pa]	3	6	11	25	44	69							
	L _{0.2} (+10K)	[m]	1.9	3.1	4	5.7	7.1	8.2							
LD-18/3 L=1000 mm	L _{WA}	[dB (A)]		<25	26	33	39	44	49	53					
	Δp _t	[Pa]		4	8	17	31	49	70	95					
	L _{0.2} (+10K)	[m]		1.3	1.9	3.1	4	5	5.8	6.5					
LD-18/3 L=1500 mm	L _{WA}	[dB (A)]			23	28	33	37	41	45	48	51			
	Δp _t	[Pa]			5	10	18	28	41	56	73	92			
	L _{0.2} (+10K)	[m]			1	1.9	2.7	3.4	4	4.7	5.2	5.8			
LD-18/3 L=2000 mm	L _{WA}	[dB (A)]				26	29	33	36	39	42	45	47	52	56
	Δp _t	[Pa]				3	5	8	12	16	21	27	34	48	66
	L _{0.2} (+10K)	[m]				1.3	1.9	2.5	3.1	3.6	4	4.5	5	5.8	6.5
LD-18/4 L=500 mm	L _{WA}	[dB (A)]	21	27	33	42	50	56	61						
	Δp _t	[Pa]	2	3	6	14	25	39	56						
	L _{0.2} (+10K)	[m]	2.1	3.3	4.1	5.4	6.4	7.2	7.9						

Definition of symbols

L_{WA} A-weighted sound power level

Δp_t Total pressure drop calculated to normal conditions

L_{0.2} (+10 °C) Isothermal throw distance of supply air jet with temperature +10K, when its velocity drops down to 0.2 m/s

Type	Q	[l/s]	27.8	41.7	55.6	83.3	111.1	138.9	166.7	194.4	222.2	250.0	277.8	333.3	388.9
		[m ³ /h]	100	150	200	300	400	500	600	700	800	900	1000	1200	1400
LD-18/4 L=1000 mm	L _{WA}	[dB (A)]			<25	30	36	41	45	49	53	56			
	Δp _t	[Pa]			4	10	18	27	39	54	70	89			
	L _{0.2} (+10K)	[m]			2.1	3.3	4.1	4.8	5.4	6	6.5	6.9			
LD-18/4 L=1500 mm	L _{WA}	[dB (A)]				26	30	34	37	41	44	47	50	54	
	Δp _t	[Pa]				6	10	16	23	32	41	52	65	93	
	L _{0.2} (+10K)	[m]				2.1	2.9	3.6	4.1	4.6	5	5.5	5.8	6.5	
LD-18/4 L=2000 mm	L _{WA}	[dB (A)]					27	30	33	36	39	41	44	48	52
	Δp _t	[Pa]					3	5	7	10	13	16	20	29	39
	L _{0.2} (+10K)	[m]					2.1	2.8	3.3	3.8	4.2	4.5	4.8	5.5	6

Pressure drop

(valid for horizontal discharge and plenum box with 100 % opened volume control damper)

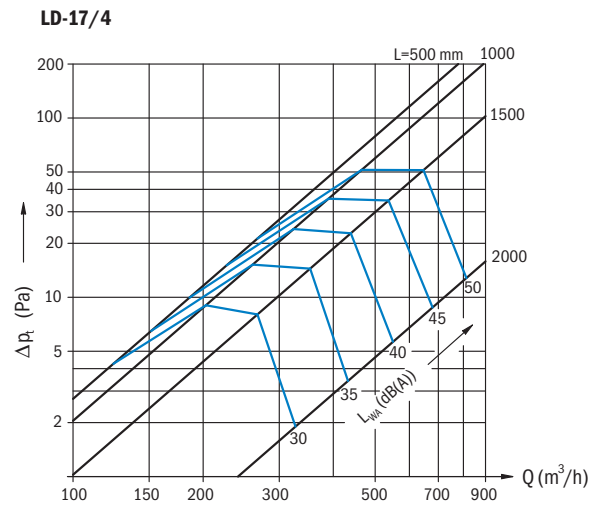
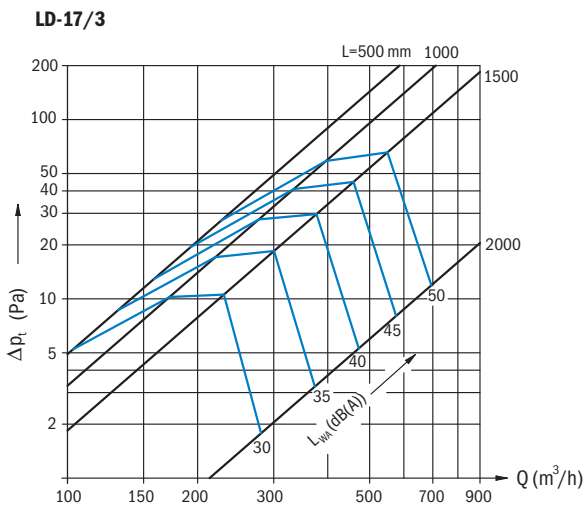
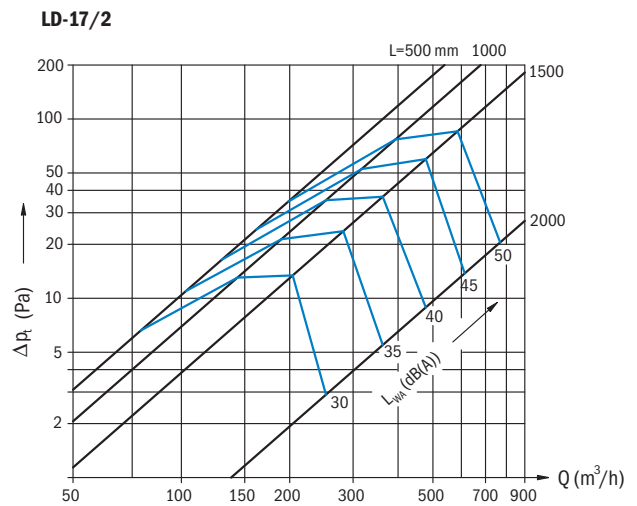
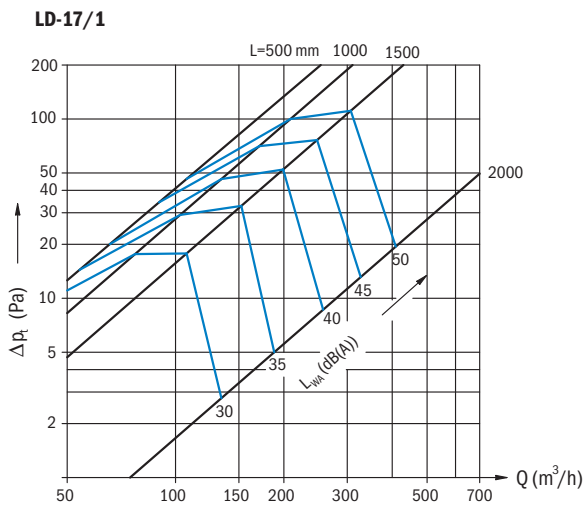

VENTILATING GRILLES, VENTILATING VALVES
 CIRCULAR DIFFUSERS, SQUARE DIFFUSERS
 SWIRL DIFFUSERS, VARIABLE SWIRL DIFFUSERS
 SLOT DIFFUSERS, ROUND DUCT DIFFUSERS
 AIR DISPLACEMENT UNITS
 SUPPLY AIR NOZZLES
 EXTERNAL ELEMENTS
 AIR FLOW CONTROL UNITS
 SOUND ATTENUATORS, SOUND ATTENUATING LOUVERES

Correction factors

LD-17/1	Type of discharge	Horizontal		Vertical	
		Open	Closed	Open	Closed
L=500	Δp_t	x 1	x 1.1	x 1.1	x 1.5
	L_{WA}	-	+ 1	-	+ 2
L=1000	Δp_t	x 1	x 1.2	x 1.2	x 1.5
	L_{WA}	-	+ 2	-	+ 1
L=1500	Δp_t	x 1	x 1.3	x 1.2	x 1.6
	L_{WA}	-	+ 2	-	+ 1
L=2000	Δp_t	x 1	x 2.9	x 2.0	x 2.7
	L_{WA}	-	+ 2	-	-

LD-17/2	Type of discharge	Horizontal		Vertical	
		Open	Closed	Open	Closed
L=500	Δp_t	x 1	x 2	x 1.0	x 2.2
	L_{WA}	-	+ 4	+ 1	+ 2
L=1000	Δp_t	x 1	x 2.3	x 1.2	x 2.2
	L_{WA}	-	+ 4	+ 1	+ 2
L=1500	Δp_t	x 1	x 2.3	x 1.2	x 2.3
	L_{WA}	-	+ 3	-	+ 1
L=2000	Δp_t	x 1	x 3	x 1.6	x 3.4
	L_{WA}	-	+ 3	-	+ 1

LD-17/3	Type of discharge	Horizontal		Vertical	
		Open	Closed	Open	Closed
L=500	Δp_t	x 1	x 2.5	x 1.1	x 2.4
	L_{WA}	-	+ 5	+ 1	+ 4
L=1000	Δp_t	x 1	x 2.6	x 1.2	x 2.5
	L_{WA}	-	+ 6	+ 2	+ 4
L=1500	Δp_t	x 1	x 2.7	x 1.2	x 2.8
	L_{WA}	-	+ 6	+ 2	+ 3
L=2000	Δp_t	x 1	x 3.2	x 2.5	x 6
	L_{WA}	-	+ 5	+ 1	+ 2

LD-17/4	Type of discharge	Horizontal		Vertical	
		Open	Closed	Open	Closed
L=500	Δp_t	x 1	x 2.2	x 1.2	x 2.4
	L_{WA}	-	+ 6	+ 2	+ 3
L=1000	Δp_t	x 1	x 2.4	x 1.2	x 2.4
	L_{WA}	-	+ 5	+ 1	+ 3
L=1500	Δp_t	x 1	x 2.7	x 1.2	x 2.7
	L_{WA}	-	+ 6	+ 1	+ 2
L=2000	Δp_t	x 1	x 5	x 1.9	x 4.3
	L_{WA}	-	+ 6	+ 1	+ 2

Pressure drop

(valid for horizontal discharge and plenum box with 100 % opened volume control damper)

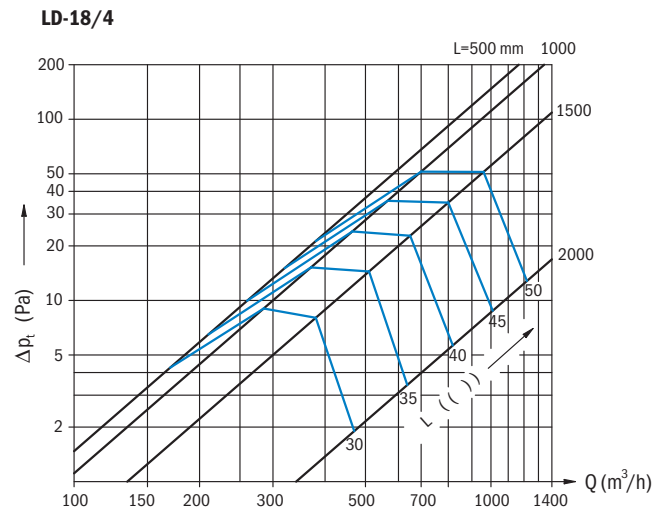
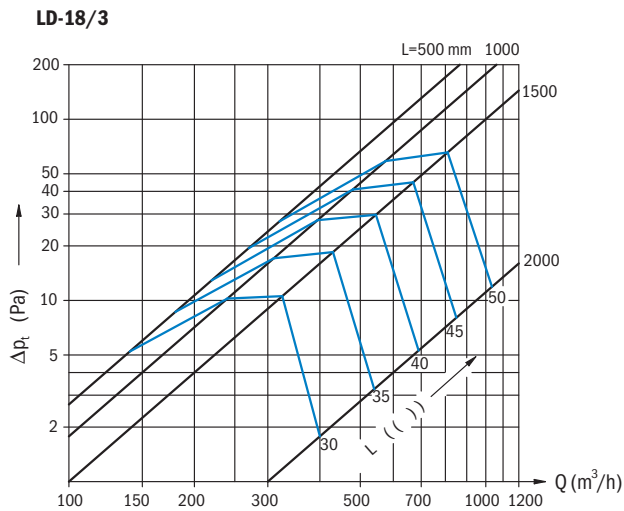
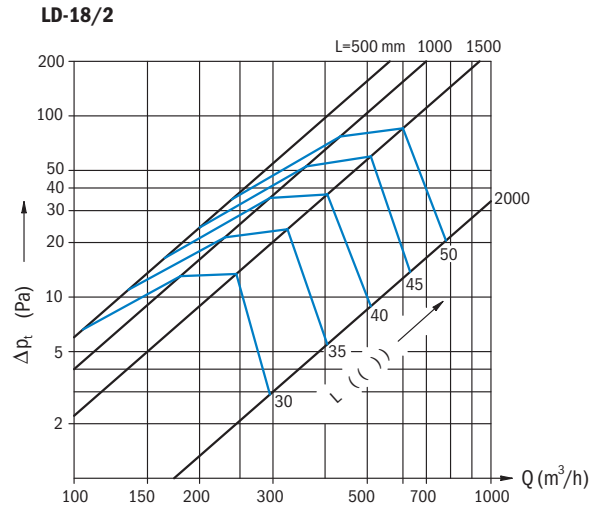
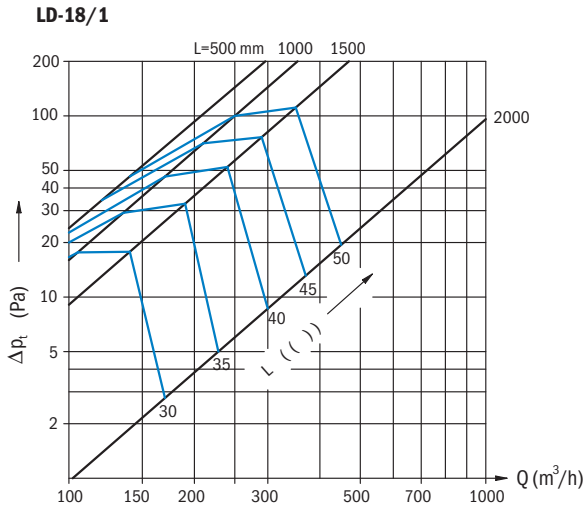

VENTILATING GRILLES,
VENTILATING VALVES

CIRCULAR DIFFUSERS,
SQUARE DIFFUSERS

SWIRL DIFFUSERS,
VARIABLE SWIRL
DIFFUSERS

SLOT DIFFUSERS,
ROUND DUCT DIFFUSERS

AIR DISPLACEMENT
UNITS

SUPPLY AIR NOZZLES

EXTERNAL ELEMENTS

AIR FLOW
CONTROL UNITS

SOUND ATTENUATORS,
SOUND ATTENUATING
LOUVRES

Correction factors

LD-18/1	Type of discharge	Horizontal		Vertical	
		Open	Closed	Open	Closed
Length	Volume control damper				
L=500	Δp_t	x 1	x 1	x 1	x 1.4
	L_{WA}	-	+ 1	-	-
L=1000	Δp_t	x 1	x 1.1	x 1.1	x 1.4
	L_{WA}	-	+ 1	-	-
L=1500	Δp_t	x 1	x 1.2	x 1.1	x 1.5
	L_{WA}	-	+ 1	-	-
L=2000	Δp_t	x 1	x 2.8	x 1.9	x 2.6
	L_{WA}	-	+ 1	-	-

LD-18/2	Type of discharge	Horizontal		Vertical	
		Open	Closed	Open	Closed
Length	Volume control damper				
L=500	Δp_t	x 1	x 2.1	x 1	x 2.1
	L_{WA}	-	+ 3	-	+ 1
L=1000	Δp_t	x 1	x 2.2	x 1.1	x 2.1
	L_{WA}	-	+ 3	-	+ 1
L=1500	Δp_t	x 1	x 2.2	x 1.1	x 2.2
	L_{WA}	-	+ 3	-	+ 1
L=2000	Δp_t	x 1	x 3	x 1.6	x 3.3
	L_{WA}	-	+ 3	-	+ 1

LD-18/3	Type of discharge	Horizontal		Vertical	
		Open	Closed	Open	Closed
Length	Volume control damper				
L=500	Δp_t	x 1	x 2.5	x 1.0	x 2.4
	L_{WA}	-	+ 6	-	+ 3
L=1000	Δp_t	x 1	x 2.5	x 1.1	x 2.5
	L_{WA}	-	+ 6	-	+ 3
L=1500	Δp_t	x 1	x 2.5	x 1.2	x 2.7
	L_{WA}	-	+ 6	-	+ 2
L=2000	Δp_t	x 1	x 3.1	x 2.8	x 6.5
	L_{WA}	-	+ 6	-	+ 3

LD-18/4	Type of discharge	Horizontal		Vertical	
		Open	Closed	Open	Closed
Length	Volume control damper				
L=500	Δp_t	x 1	x 2.2	x 1	x 2.4
	L_{WA}	-	+ 5	+ 1	+ 2
L=1000	Δp_t	x 1	x 2.3	x 1.1	x 2.5
	L_{WA}	-	+ 5	-	+ 2
L=1500	Δp_t	x 1	x 2.6	x 1.1	x 2.6
	L_{WA}	-	+ 5	-	+ 2
L=2000	Δp_t	x 1	x 5	x 1.8	x 4.3
	L_{WA}	-	+ 4	-	+ 2