



FORMO

Mounting instruction
Montage vejledning
Montageanvisning
Asennusohje
Montageanweisung
Istruzioni di montaggio
Инструкция по монтажу
Instructions de montage

PKA



PCA

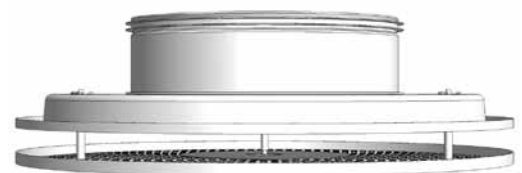

LKA

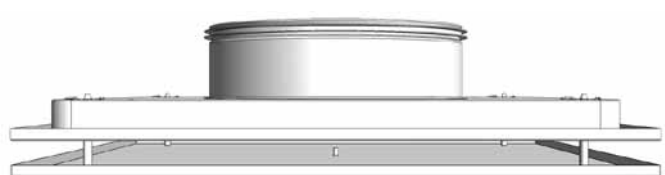

LCA

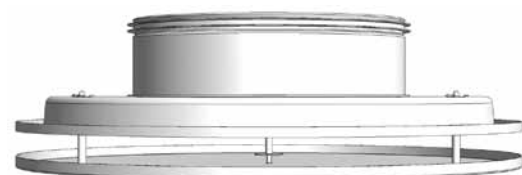

CRL

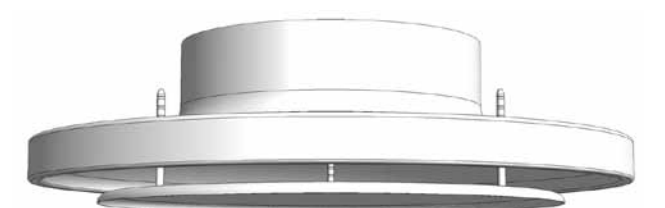



Formo

Contents	Maintenance / Vedligeholdelse / Underhåll / Huolto / Wartung /	
Indhold	Manutenzione / Обозначения / Entretien.....	2
Innehållsförteckning	Symbols / Symboler / Symbolit / Symbole / Simboli / Обозначения / Symboles.....	2
Sisällysluettelo	PKA.....	3
Inhalt	PCA.....	4
Sommario	LKA.....	5
Содержание	LCA.....	6
Sommaire	CRL.....	7
	Accessories - Order code / Tilbehør - Bestillings kode / Tillbehör - Beställningskod /	
	Lisävarusteet - Tilaukoodi / Zubehör - Bestellcode / accessori - Ordinazione /	
	Аксессуары - Код Заказа / Accessoires - codification.....	8
	DKZ / DDZ / DCZ.....	9
	DAZ.....	12
	DRZ /CAZ	
	Damper / Spjæld / Spjäll / Säästöpeltil / Drossel / Serranda / Регулятор / Registre.....	13
	MBB	
	Plenum box / Trykfordelingsboks / Tryckfördelningslåda / Liitäntälaatikko	
	Anschlusskasten / Plenum / Расширительные камеры / Plénum.....	14
	LM	
	Module plates / modulplader / Modulramar / Beställningskod / Moduulilevy / Modulplatten /	
	Piastra modulare per controsoffiti / Zubehör / Module plates / Plaque d'habillage.....	18

Maintenance	UK	- The diffuser can be demounted and vacuum cleaned by using a smooth nozzle brush or wiped off by using a sponge or wiped off with a clean damp sponge or soft cotton cloth.
Vedligeholdelse	DK	- Diffusoren kan demonteres og støvsuges med et blødt børstestykke eller aftørres med en fugtig klud.
Underhåll	SE	- Donet kan demonteras och dammsugas med ett mjukt borstmunstycke eller torkas av med en fuktig trasa.
Huolto	FI	- Laite voidaan puhdistaa imurilla käyttäen pehmeää harjaosaa tai se voidaan pyyhkiä kostutetulla kangasliinalla.
Wartung	DE	- Der Durchlass kann zur Reinigung demontiert werden. Die Reinigung erfolgt entweder mit einem Staubsauger mit einer weichen Düsenbürste oder mit einem weichen Baumwolltuch, das in klares Wasser getaucht und gut ausgewrungen wurde.
Manutenzione	IT	- Il diffusore può essere pulito con una spazzola morbida oppure con una spugna o un panno di cotone leggermente umidi.
Обслуживание	RU	- Диффузор можно очищать, используя гладкую щетку, вытирать губкой или влажной сильно отжатой хлопчатобумажной тканью.
Entretien	FR	- Le diffuseur peut être démonté et nettoyé avec une brosse d'aspirateur, une éponge propre ou un chiffon humide doux en coton.

Symbols Symboler Symboler Symbolit Symbole Simboli Обозначения Symboles		Supply air Indblæsning Tilluft Sisäänpuhallus Zuluft Aria di mandata Приточная вентиляция Soufflage		Exhaust air Udsugning Frånluft Poistoilma Abluft Aria di estrazione Вытяжная вентиляция Extraction		1, 2, 3 - way 1, 2, 3 - vejs
						1, 2, 3 - vägs 1, 2, 3 - suuntaa
						1, 2, 3 - seitig 1, 2, 3 - vie
						1, 2, 3 - сторониий 1, 2, 3 - directions



Formo

PKA

Measure / weight
 Mål / vægt
 Mått / vikt
 Mitta / paino
 Abmessungen /Gewicht
 Misure / peso
 Размер / вес
 Dimensions / poids

PKA

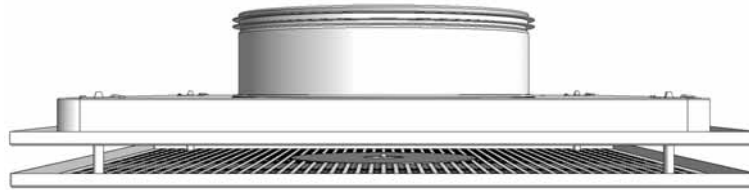

Ød mm	A mm	U mm	kg
125	235	200	1,10
160	295	260	1,80
200	395	360	2,80
250	495	460	4,20
315	595	560	5,70
400	595	560	5,70

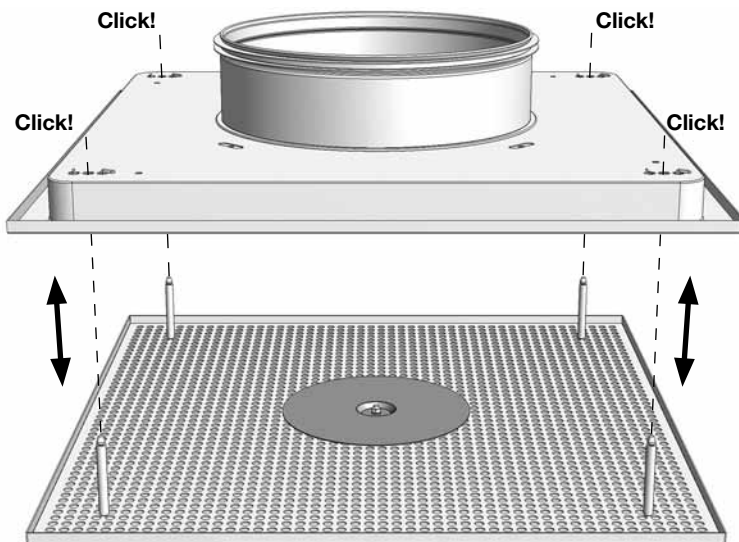
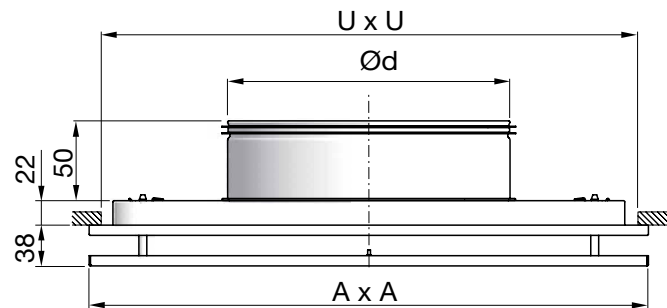

No tools
 Ingen værktøj
 Inga verktyg
 Ei työkaluja
 Keine Werkzeuge
 Nessun attrezzo
 Без инструмента
 Sans outil

Order code
 Ordre kode
 Beställningskod
 Tuotekoodi
 Bestellcode
 Codice d'ordine
 Код Заказа
 Codification

PKA — Ød



Formo

PCA

Measure / weight
 Mål / vægt
 Mått / vikt
 Mitta / paino
 Abmessungen / Gewicht
 Misure / peso
 Размер / вес
 Dimensions / poids

PCA

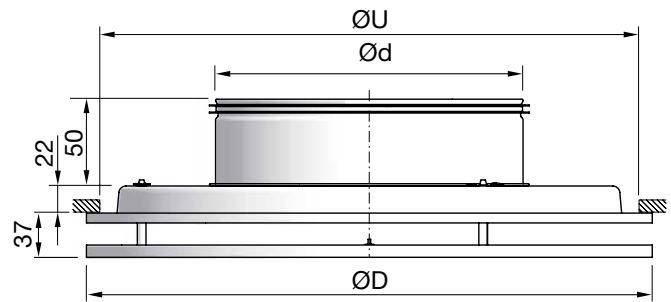
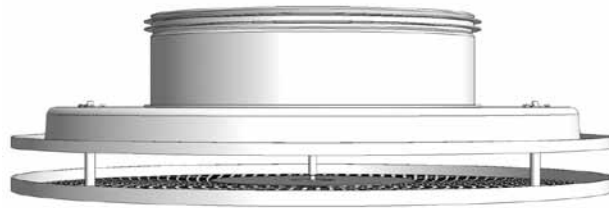

Ød mm	ØD mm	ØU mm	kg
100	240	200	1,00
125	240	200	1,00
160	300	260	1,50
200	360	320	2,30
250	460	420	3,40
315	540	500	4,60
400	540	500	4,60

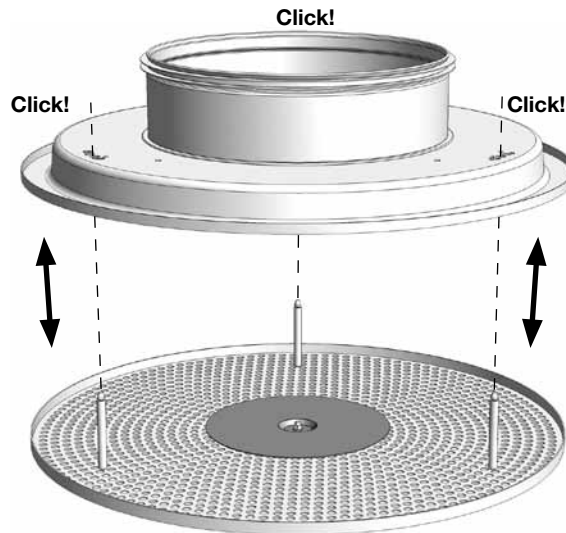

No tools
 Ingen værktøj
 Inga verktyg
 Ei työkaluja
 Keine Werkzeuge
 Nessun attrezzo
 Без инструмента
 Sans outil

Order code
 Ordre kode
 Beställningskod
 Tuotekoodi
 Bestellcode
 Codice d'ordine
 Код Заказа
 Codification

PCA — Ød



Formo

LKA

Measure / weight
 Mål / vægt
 Mått / vikt
 Mitta / paino
 Abmessungen / Gewicht
 Misure / peso
 Размер / вес
 Dimensions / poids

LKA

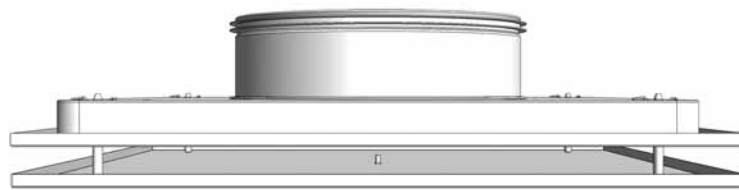

Ød mm	A mm	U mm	kg
125	235	200	1,10
160	295	260	1,80
200	395	360	2,80
250	495	460	4,20
315	595	560	5,70
400	595	560	5,70

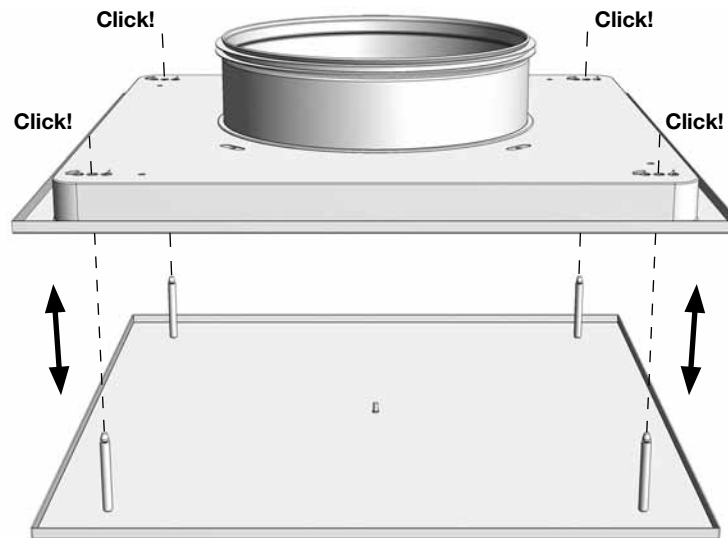
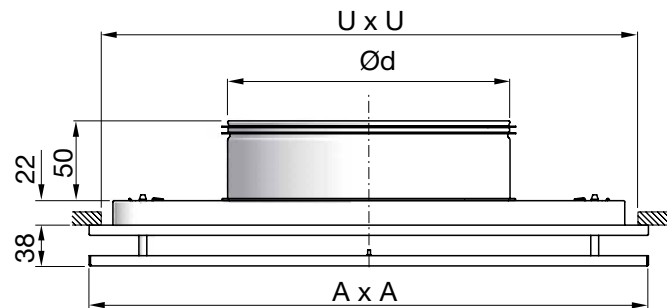

No tools
 Ingen værktøj
 Inga verktyg
 Ei työkaluja
 Keine Werkzeuge
 Nessun attrezzo
 Без инструмента
 Sans outil

Order code
 Ordre kode
 Beställningskod
 Tuotekoodi
 Bestellcode
 Codice d'ordine
 Код Заказа
 Codification

LKA — **Ød**



Formo

LCA

Measure / weight
 Mål / vægt
 Mått / vikt
 Mitta / paino
 Abmessungen / Gewicht
 Misure / peso
 Размер / вес
 Dimensions / poids

LCA

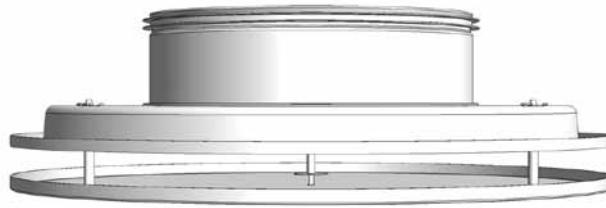

Ød mm	ØD mm	ØU mm	kg
100	240	200	1,00
125	240	200	1,00
160	300	260	1,50
200	360	320	2,30
250	460	420	3,40
315	540	500	4,60
400	540	500	4,60

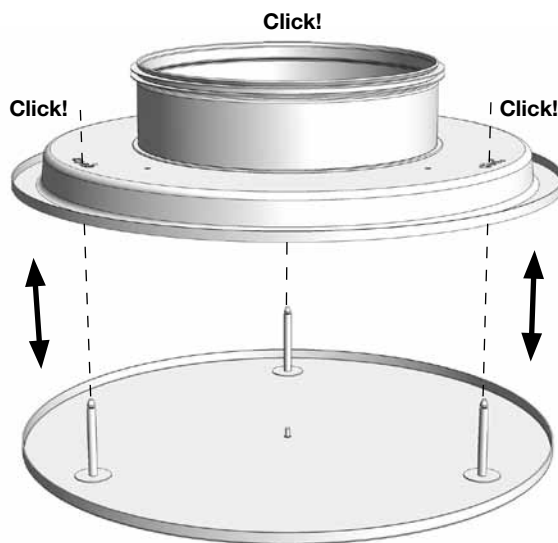
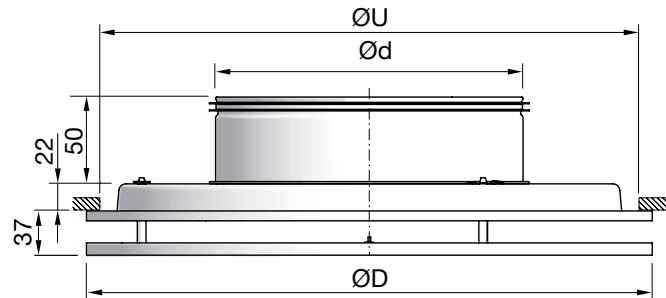

No tools
 Ingen værktøj
 Inga verktyg
 Ei työkaluja
 Keine Werkzeuge
 Nessun attrezzo
 Без инструмента
 Sans outil

Order code
 Ordre kode
 Beställningskod
 Tuotekoodi
 Bestellcode
 Codice d'ordine
 Код Заказа
 Codification

LCA — **Ød**



Formo

CRL

Measure / weight
 Mål / vægt
 Mått / vikt
 Mitta / paino
 Abmessungen / Gewicht
 Misure / peso
 Размер / вес
 Dimensions / poids

CRL

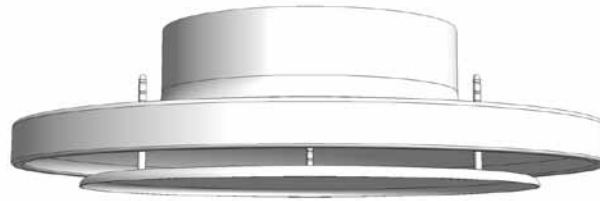

Ød mm	ØA mm	B mm	C mm	ØE mm	ØU mm	kg
100	188	15	60	146	170	0,30
125	238	20	65	180	210	0,50
160	288	25	65	220	255	0,60
200	388	28	72	300	355	1,10
250	488	33	82	380	390	1,60
315	588	33	97	490	465	2,50
400	720	40	100	590	670	3,80

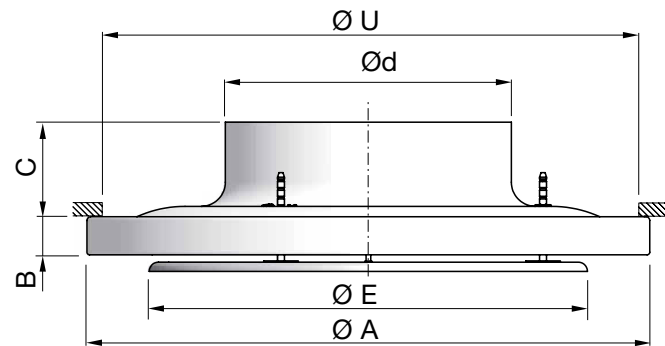

Vertical supply air
 Vertikal Indblæsning
 Vertikal inblåsning
 Pystysuora puhalluskuvio
 Vertikale Luftführung
 Mandata verticale
 Вертикальная подача воздуха
 Soufflage vertical

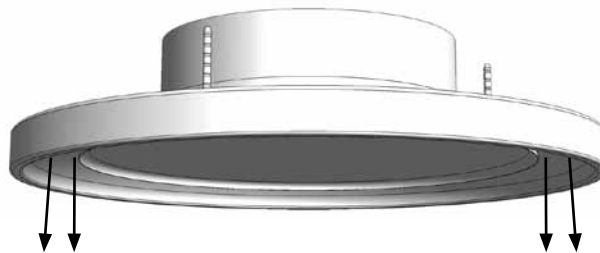

No tools
 Ingen værktøj
 Inga verktyg
 Ei työkaluja
 Keine Werkzeuge
 Nessun attrezzo
 Без инструмента
 Sans outil

Horizontal supply air
 Horizontal Indblæsning
 Horisontell inblåsning
 Vaakasuora puhalluskuvio
 Horizontale Luftführung
 Mandata orrizzontale
 Горизонтальная подача воздуха
 Soufflage horizontal

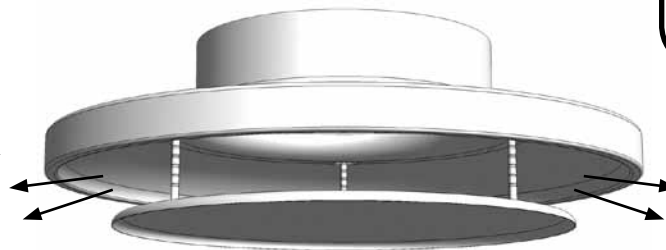

Order code
 Ordre kode
 Beställningskod
 Tuotekoodi
 Bestellcode
 Codice d'ordine
 Код Заказа
 Codification





Formo

Overview

Oversigt

Överikt

Yleiskatsaus

Übersicht

Panoramica

Обзор

Aperçu

Accessories / Order code
Tilbehør / Bestillings kode
Tillbehör / Beställningskod
Lisävarusteet / Jotta koodi
Zubehör / Bestellbeispiel
Accessori / Ordinanzaione
Аксессуары / Код Заказа
Accessoires / codification

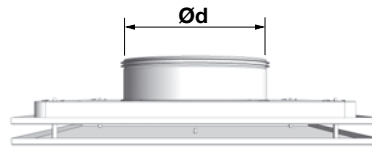

DKZ/DDZ/DCZ



DKZ (PKA, LKA)
DDZ (PCA, LCA)
DCZ (CRL)



DAZ

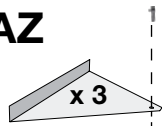

DRZ / CAZ

Damper - Spjæld - Spjäll - Säätöpelti -
 Drossel - Serranda - Регулятор - Register



DRZ (PKA, PCA, LKA, LCA)



CAZ (CRL)

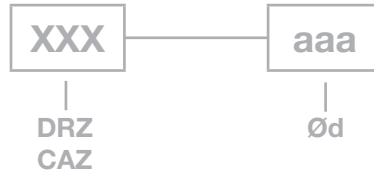

MBB

PKA, LKA, PCA, LCA, CRL

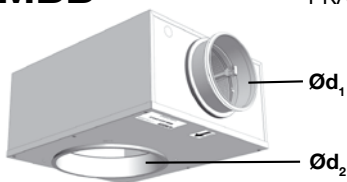

(Ød₂ ≈ Ød)

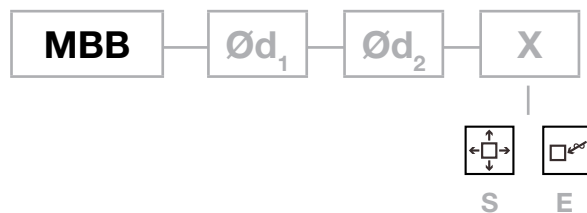

LM

PKA, LKA, PCA, LCA

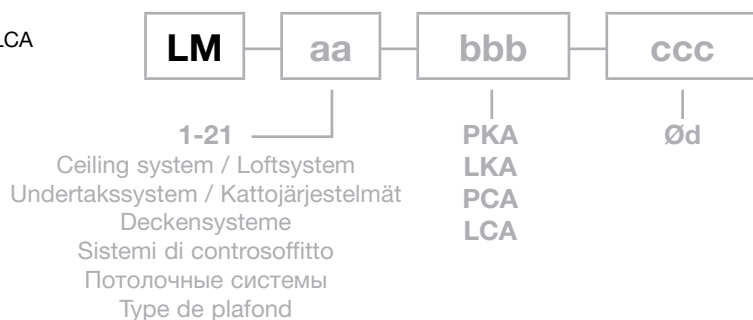
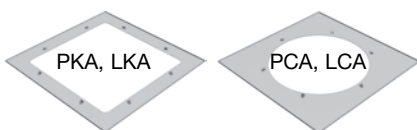



Formo

DKZ/DDZ/DCZ

Accessories Tilbehør Tillbehör Lisävarusteet Zubehör Accessori Аксессуары Accessoires

Accessories
Tilbehør
Tillbehör
Lisävarusteet
Zubehör
Accessori
Аксессуары
Accessoires

DKZ/DDZ/DCZ

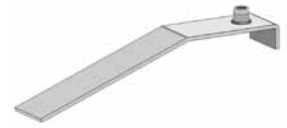
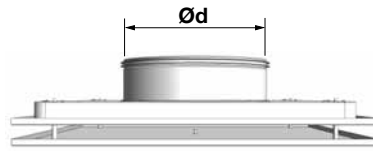



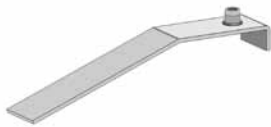

DKZ/DDZ/DCZ

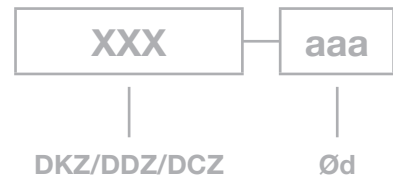

DKZ (PKA, LKA)
DDZ (PCA, LCA)
DCZ (CRL)



Set / Sæt / Sats / Saja / Set / Set / Set (RUS) / Kit			
DKZ (PKA / LKA)	=		x 4
DCZ (CRL)	=		x 3
DDZ (PCA / LCA)	Ød =125 =		x 2
	Ød >125 =		x 4

PKA, LKA

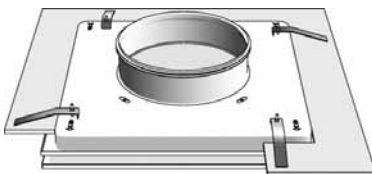

PCA, LCA



CRL

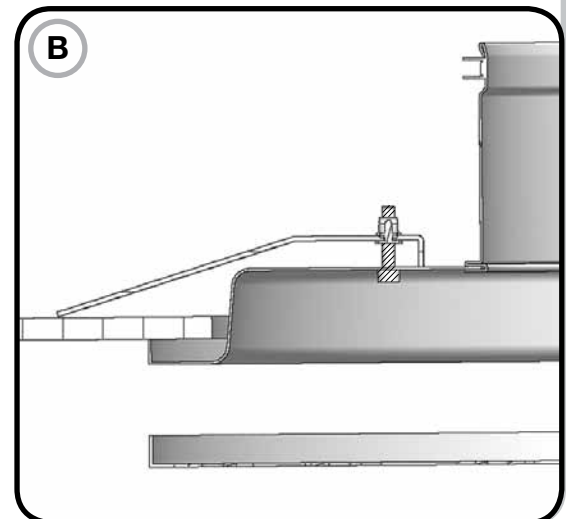
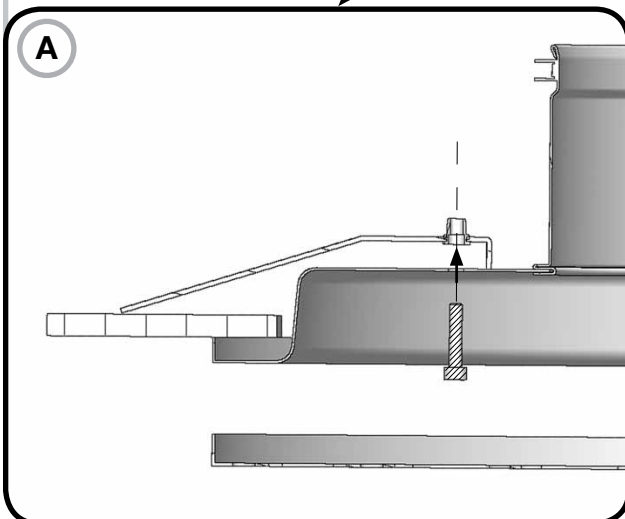
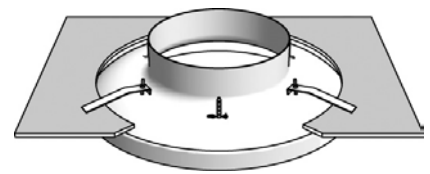



FORMO

DKZ/DDZ/DCZ

Accessories

Tilbehør

Tillbehör

Lisävarusteet

Zubehör

Accessori

Аксессуары

Accessoires

Ceiling grid opening
Udsparing
Håltagning
Rakenneaukko
Aussparung erstellen
Dimensione del foro
Отверстие в потолке
Ouverture dans le plafond

DKZ/DDZ/DCZ

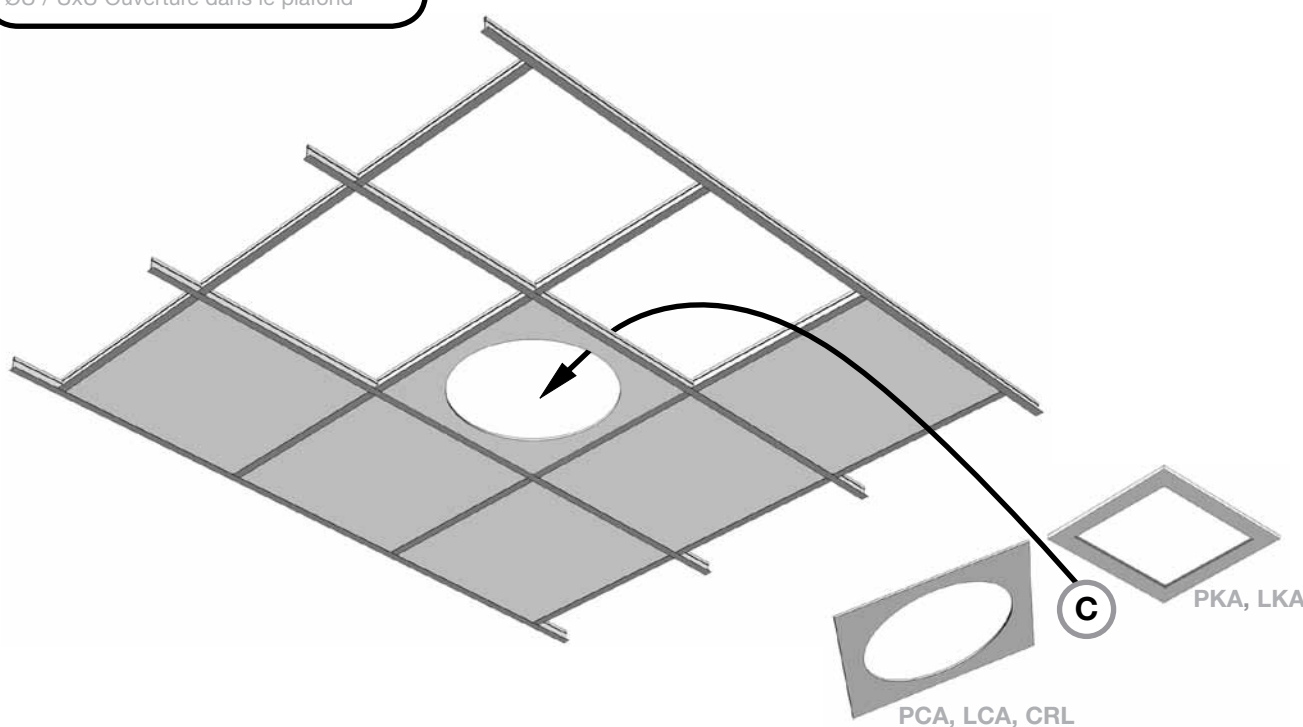
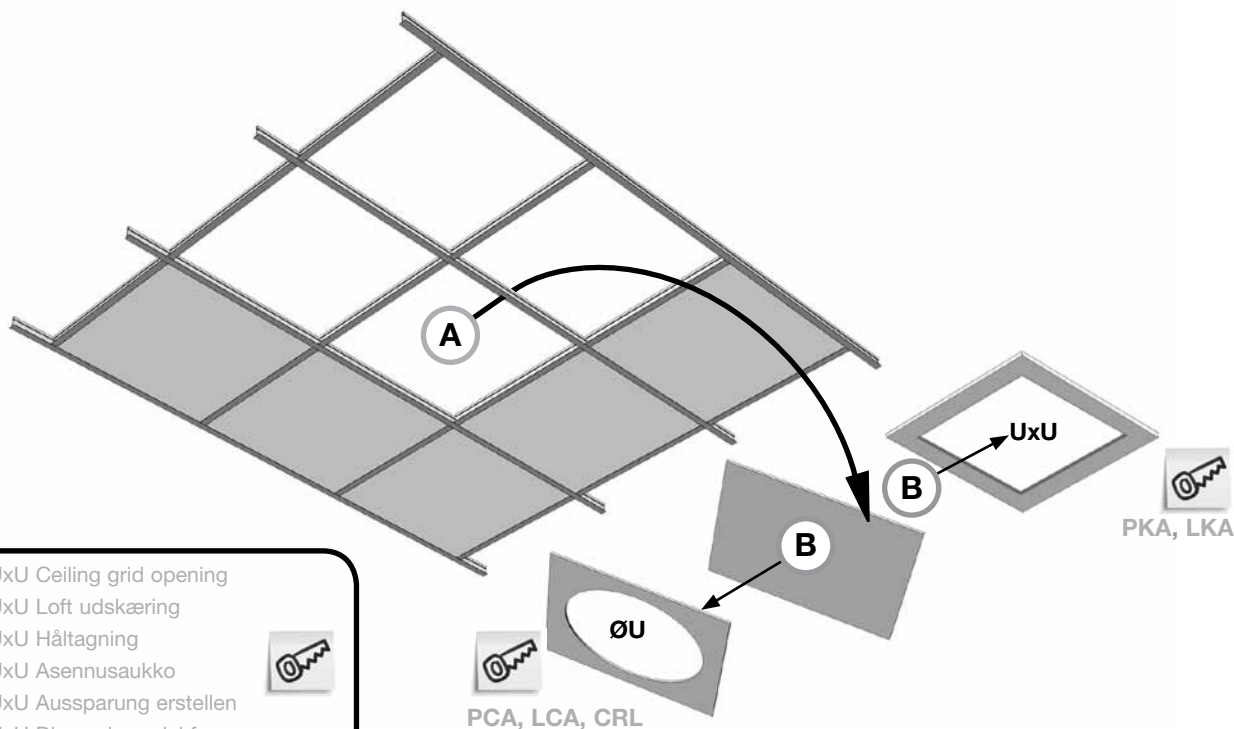



FORMO

DKZ/DDZ/DCZ

Accessories

Tilbehør

Tillbehör

Lisävarusteet

Zubehör

Accessori



Аксессуары

Accessoires

Mount diffuser with mounting brackets
Monter armatur med monteringsbøjler
Montera don med monteringsklammer
Mount diffuser with mounting brackets -FIN
Montieren Sie der Durchlass mit Montagebügel
Installazione del diffusore con staffe di montaggio
Mount diffuser with mounting brackets -RUS
Installation du diffuseur avec pattes de montage

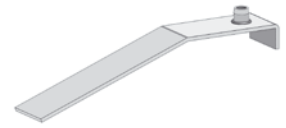
DKZ/DDZ/DCZ



Set / Sæt / Sats / Saja / Set / Set / Set / Kit			
DKZ (PKA / LKA)	=		x 4
DCZ (CRL)	=		x 3
DDZ (PCA / LCA)	Ød =125	=	x 2
	Ød >125	=	x 4

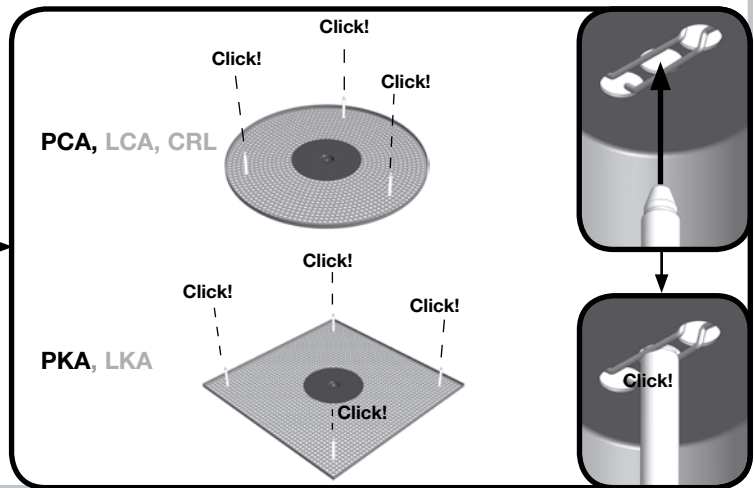
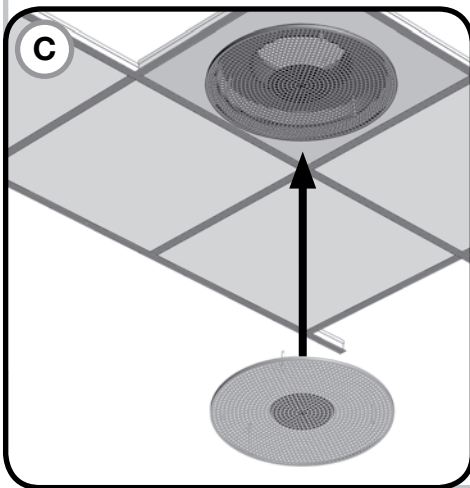
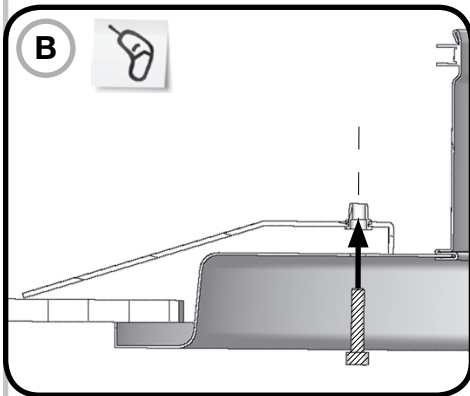
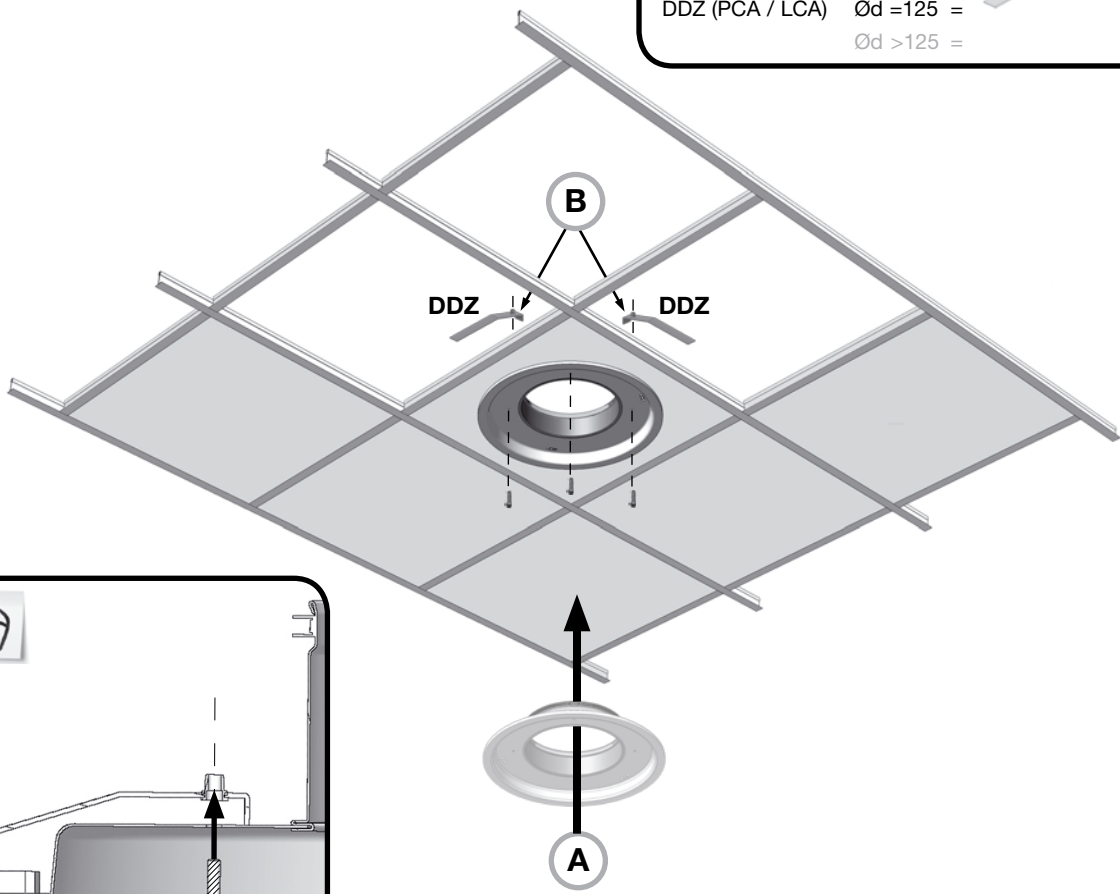



Formo

DAZ

Accessories Tilbehør Tillbehör Lisävarusteet Zubehör Accessori Аксессуары Accessoires

Accessories
Tilbehør
Tillbehör
Lisävarusteet
Zubehör
Accessori
Аксессуары
Accessoires

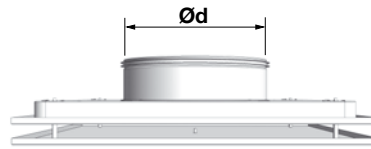

DAZ



PKA, LKA, PCA, LCA

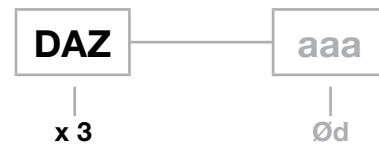

Set / Sæt / Sats / Saja
 Set /Set (ITA) / Set (RUS) / Kit

PKA, LKA

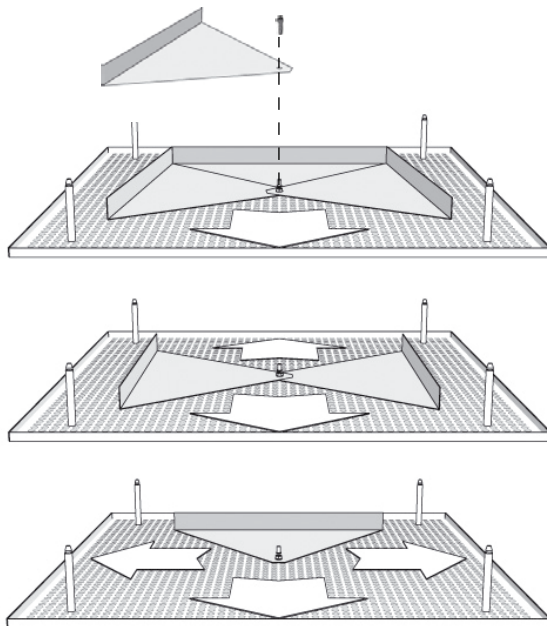

PCA, LCA

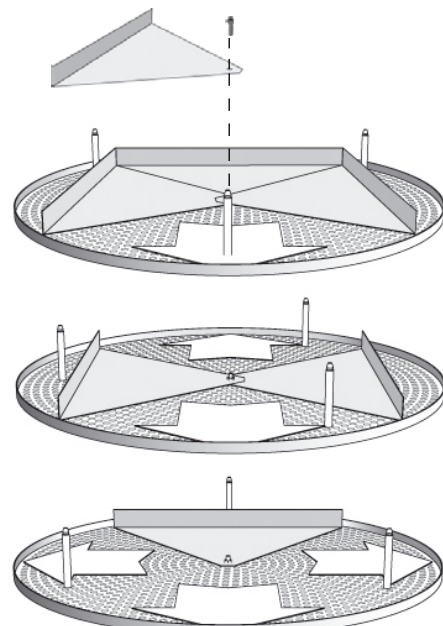

!

UK - DAZ is not used with CRL
DK - DAZ anvendes ikke til CRL
SE - DAZ används inte för CRL
FI - DAZ is not used with CRL - FIN
DE - DAZ wird nicht mit CRL verwendet!
ITA - DAZ non usato per CRL
RUS - DAZ is not used with CRL
FR - DAZ n'est pas compatible avec CRL



Formo

DRZ/CAZ

Accessories Tilbehør Tillbehör Lisävarusteet Zubehör Accessori Аксессуары Accessoires

Accessories - Damper
Tilbehør - Spjæld
Tillbehör - Spjäll
Lisävarusteet - Säätöpelti
Zubehör - Drossel
Accessori - Serranda
Аксессуары - Регулятор
Accessoires - Registre

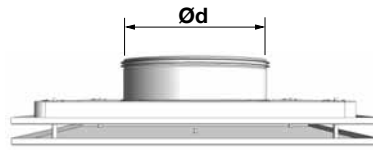

DRZ / CAZ



DRZ / CAZ Damper - Spjæld - Spjäll - Säätöpelti -
 Drossel - Serranda - Регулятор - Registre

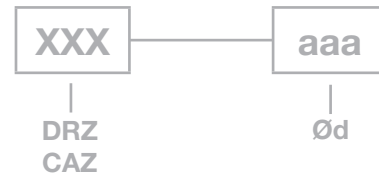

DRZ (PKA, PCA, LKA, LCA)



CAZ (CRL)

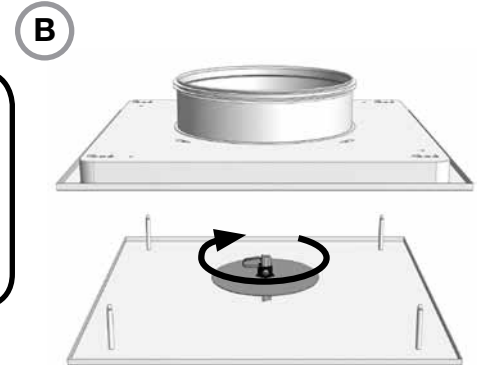
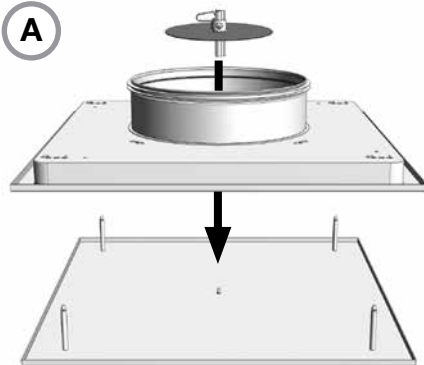

Without deflector plate
 Uden preplade
 Without deflectorplate SWE
 Without deflectorplate -FIN
 Ohne Prallplatte - DE
 Senza piastra deflettrice
 Without deflectorplate -RUS
 Sans plaque déflectrice

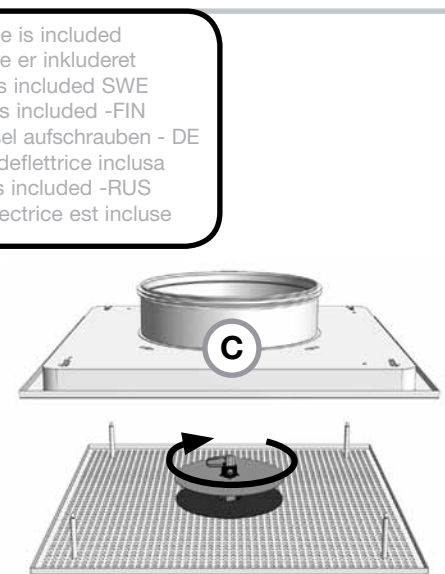
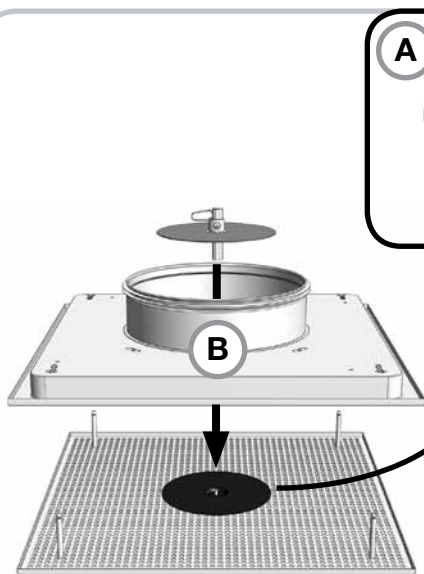

A
 Demount nut - if deflector plate is included
 Demonter møtrik - hvis preplade er inkluderet
 Demount nut - if deflector plate is included SWE
 Demount nut - if deflector plate is included -FIN
 Prallplatte über Mutter lösen und Drossel aufschrauben - DE
 Dado di smontaggio - con piastra deflettrice inclusa
 Demount nut - if deflector plate is included -RUS
 Démontez l'écrou - si la plaque déflectrice est incluse



Formo

MBB

Accessories Tilbehør Tillbehör Lisävarusteet Zubehör Accessori Аксессуары Accessoires

Accessories / Plenum box MBB
Tilbehør / Trykfordelingsboks MBB
Tillbehör / Tryckfördelningslåda MBB
Lisävarusteet / Liitäntälaatikko MBB
Zubehör / Anschlusskasten MBB
Accessori / Plenum MBB
Аксессуары / Расширительные камеры MBB
Accessoires / plénum

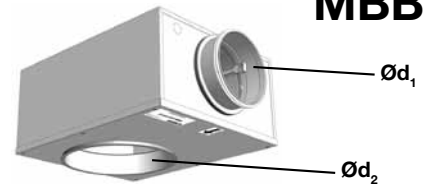
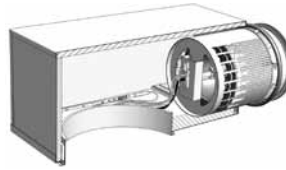

MBB

Damper
Spjæld
Spjäll
Säätöpelti
Drossel
Serranda
Регулятор
Registre

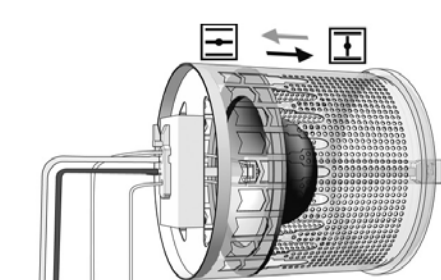

Measuring outlets
 Måleudtag
 Mätuttag
 Mittausyhteet
 Für den Anschluß
 eines Meßgerätes
 Punti per misura
 pressione
 Измерительные
 патрубки
 Prises de pression

Read the k-factor scale
 Aflæs af k-faktor skalaen
 Avläs k-faktorn
 Lue k-arvo asteikolta
 k-Wert ablesen.
 Lettura della scala
 graduate del fattore k
 Определение значения
 К-фактор
 Lire la réglette coefficient k

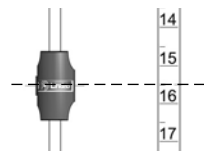

Dimensions
Dimensioner
Dimensioner
Mitat
Dimensionen
Dimensioni
Размеры
Dimensions

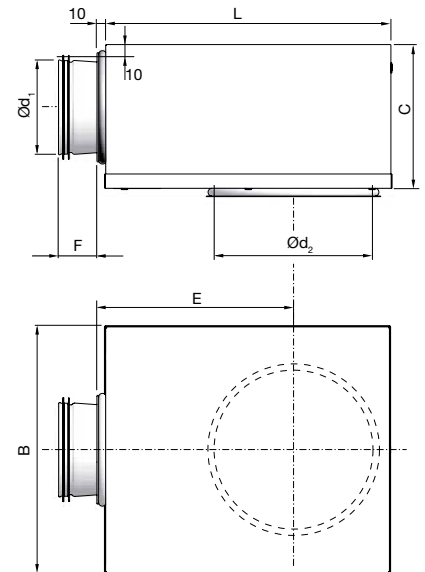

Ød ₁ mm	Ød ₂ mm	B mm	C mm	E mm	F mm	L mm	m kg
100	100	260	159	216	50	310	2,6
100	125	260	159	216	50	310	2,6
100	160	260	159	216	50	310	2,6
125	125	310	184	262	50	376	3,7
125	160	310	184	262	50	376	3,7
125	200	310	184	262	50	376	3,7
160	160	380	220	323	50	459	5,5
160	200	380	220	323	50	459	5,5
160	250	380	220	323	50	459	5,5
200	200	460	259	396	70	565	7,3
200	250	460	259	396	70	565	7,3
200	315	460	259	396	70	565	7,3
250	250	540	309	486	70	698	10,6
250	315	540	309	486	70	698	10,6
250	400	540	309	486	70	698	10,6
315	315	540	373	646	70	858	13,5
315	400	540	373	646	70	858	13,5

Order code
Ordre kode
Beställningskod
Tuotekoodi
Bestellcode
Codice d'ordine
Код Заказа
Codification

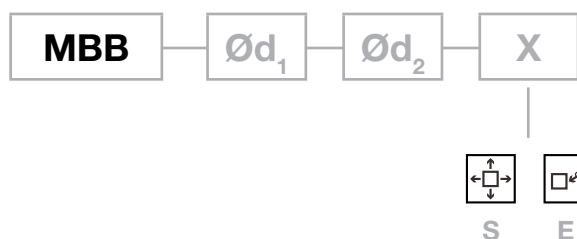



Formo

MBB

Accessories

Tilbehør

Tillbehör

Lisävarusteet

Zubehör

Accessori

Аксессуары

Accessoires

- Mounting of MBB - MHS
- Ophængning af MBB - MHS
- Upphängning av MBB - MHS
- Kannakointi MBB - MHS
- Montage des MBB - MHS
- Montaggio di MBB - MHS
- Монтаж MBB - MHS
- Montage de MBB - MHS

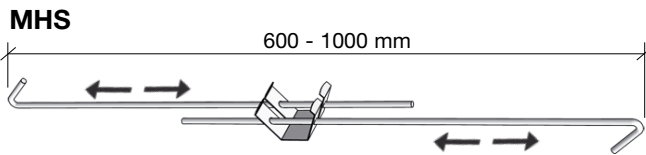
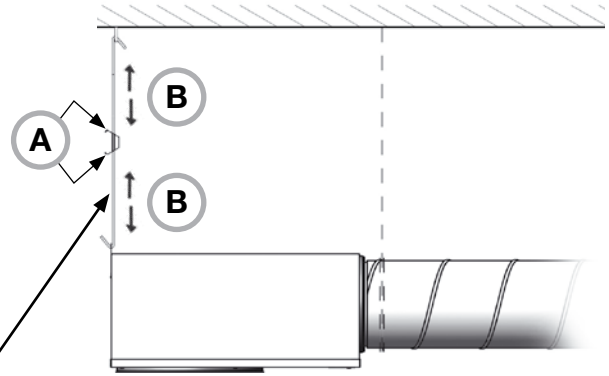

- Threaded bar
- Gevindstang
- Gängstång
- Kierretanko
- Gewindestange
- Barre filettate
- Крепежная шпилька
- Tiges filettées

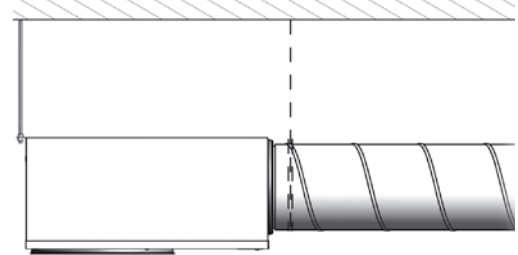
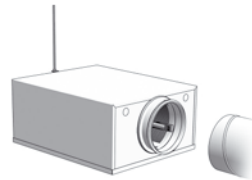

- Directly against ceiling
- Direkte mod loft
- Dikt mot tak
- Suoraan kattopintaan
- Direkt an die Decke
- Direttamente a soffitto
- к потолку
- Directement contre le plafond

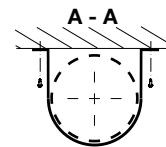
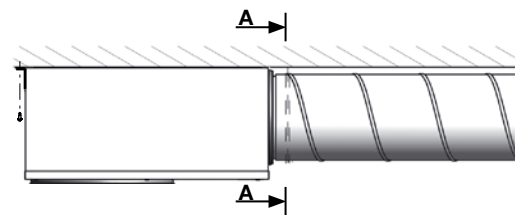
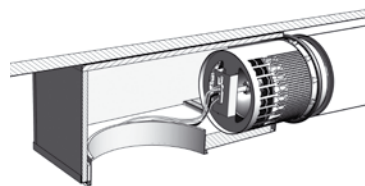

- | | |
|---------------------------------------|---|
| Mounting of MBB, details go to | - Mounting -and balancing instruction |
| Ophængning af MBB, detaljer se | - Montage -og indregulerings vejledning |
| Upphängning av MBB, details go to | - Montage och injusteringsinstruktion |
| Kannakointi MBB, details go to | - Asennus- ja säätöohjeet |
| Montage des MBB, details go to | - Montage und Einregulierungsanweisung |
| Montaggio di MBB, per dettagli vedere | - Istruzioni di montaggio e bilanciamento |
| Монтаж MBB, details go to | - Инструкция по монтажу и балансировке |
| Montage de MBB, détails voir | - Instructions de montage et réglage |





Formo

MBB

Accessories

Tilbehør

Tillbehör

Lisävarusteet

Zubehör

Accessori

Аксессуары

Accessoires

Mounting of diffuser in MBB
Montering af armatur i MBB
Mounting of diffuser in MBB - SWE
Mounting of diffuser in MBB -FIN
Durchlassmontage im MBB
Montaggio del diffusore in MBB
Mounting of diffuser in MBB -RUS
Montage du diffuseur dans MBB

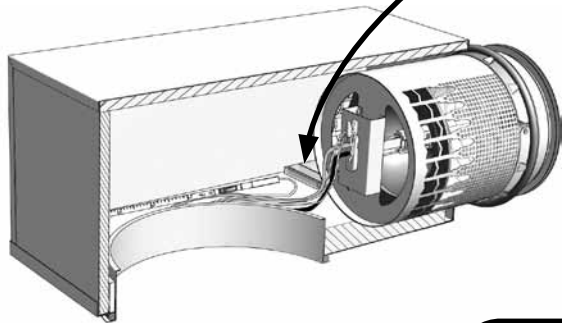

4 x Ø4,2 x 40

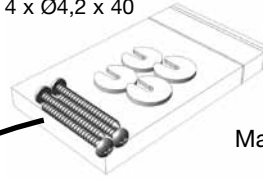

Included accessories
 Inkluderet tilbehør
 Medföljande tillbehör
 Varusteet laitteen mukana
 Enthaltene Zubehör
 Materiali inclusi in fornitura standard
 Аксессуары в комплекте
 Accessoires inclus



Screws only for mounting of diffuser + MBB
 Skruer kun til montering af armatur + MBB
 Skruvar bara för montage av don + MBB
 Screws only for mounting of diffuser + MBB -FIN
 Schrauben nur zu Montage des Durchlasses + MBB
 Viti solo per il montaggio del diffusore + MBB - ITA
 Screws only for mounting of diffuser + MBB - RUS
 Vis seulement pour le montage du diffuseur

Example:
 Eksempel:
 Exempel: MBB
 Esimerkki: 160-250-S
 Beispiel: +
 Esempio: PCA-250
 Пример:
 Exemple:

A

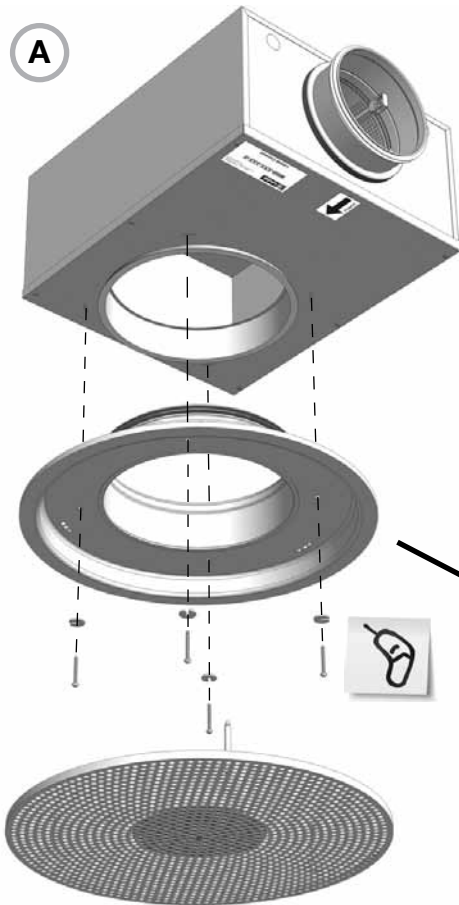

B

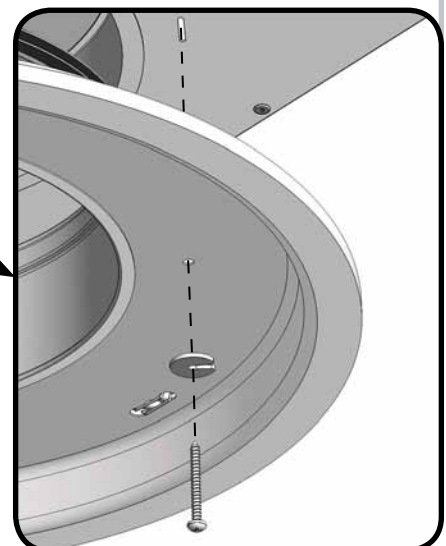
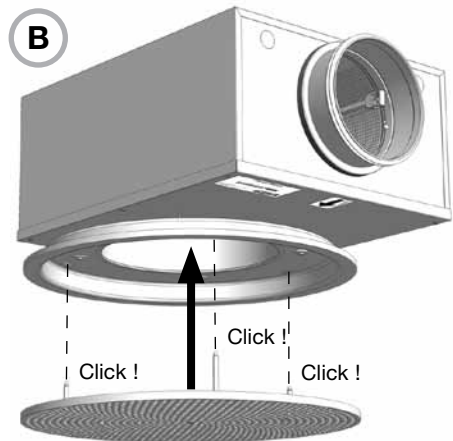



Formo

MBB/MBZ

Accessories

Tilbehør

Tillbehör

Lisävarusteet

Zubehör

Accessori

Аксессуары

Accessoires

- MBZ - Optional accessories**
- MBZ - Ekstra tilbehør**
- MBZ - Tillbehör som tillval**
- MBZ - Lisävarusteet tilauksesta**
- MBZ - Verlängerungsstutzen**
- MBZ - Accessori su richiesta**
- MBZ - Дополнительные аксессуары**
- MBZ - Accessoires optionnels**

MBZ

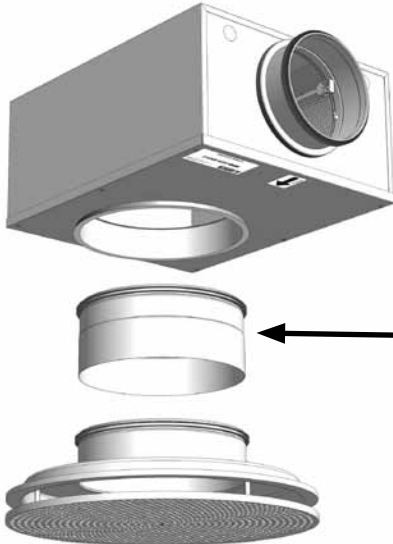

- Extension piece
- Forlængerstykke
- Förlängningsstos
- Jatkokappale
- Verlängerungsstutzen
- Manicotto maschio femmina di prolungamento
- Удлинитель
- Rallonge

! **CRL** **!**

Using CRL + MBB	=>	Always use MBZ !
Anvendelse af CRL + MBB	=>	Brug altid MBZ !
Användning av CRL + MBB	=>	Använd alltid MBZ !
Käytettäessä CRL+MBB	=>	Käytä aina MBZ liitososa !
CRL + MBB	=>	immer MBZ verwenden !
Per CRL + MBB	=>	Usare sempre MBZ!>
Using CRL + MBB	=>	Always use MBZ ! - RUS
Utiliser CRL + MBB	=>	Toujours utiliser MBZ

This will ensure full motion of faceplate
 Dette vil sikre fuld bevægelse af bundpladen
 Detta kommer att säkerställa full rörlighet av bottenplattan
 This will ensure full motion of faceplate -FIN
 Dies garantiert die Verstellbarkeit der Frontplatte! - DE
 Questo assicura la completa mobilità della piastra frontale
 This will ensure full motion of faceplate - RUS
 Ceci permettra l'utilisation optimale du cône réglable

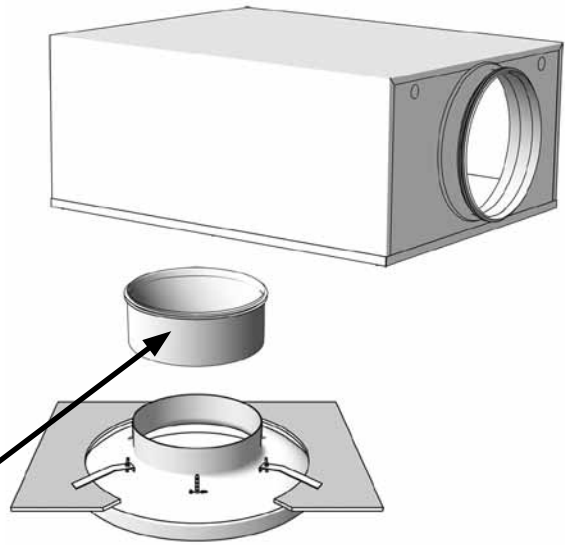



Formo

LM

Accessories

Tilbehør

Tillbehör

Lisävarusteet

Zubehör

Accessori

Аксессуары

Accessoires

Mounting of diffuser on the LM module plate
Montering af armatur på LM modulplade
Montering av don på LM modulram
Mounting of diffuser on LM module plate-FIN
Montage des Durchlasses an der Modulplatte LM
Montaggio del diffusore su cornice LM
Mounting of diffuser on LM module plate -RUS
Montage du diffuseur sur la plaque d'habillage LM

LM

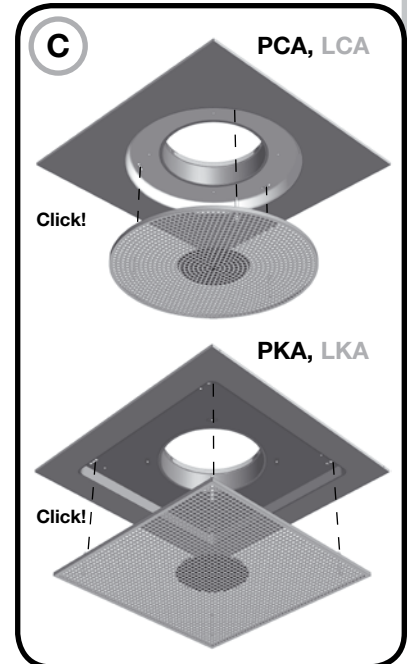
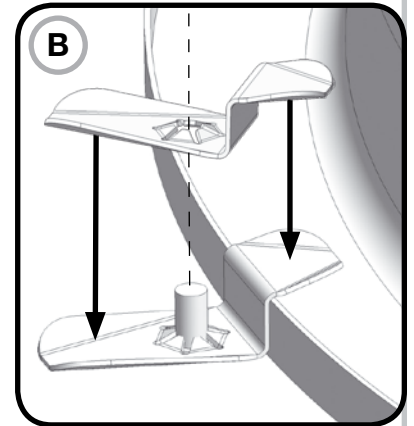
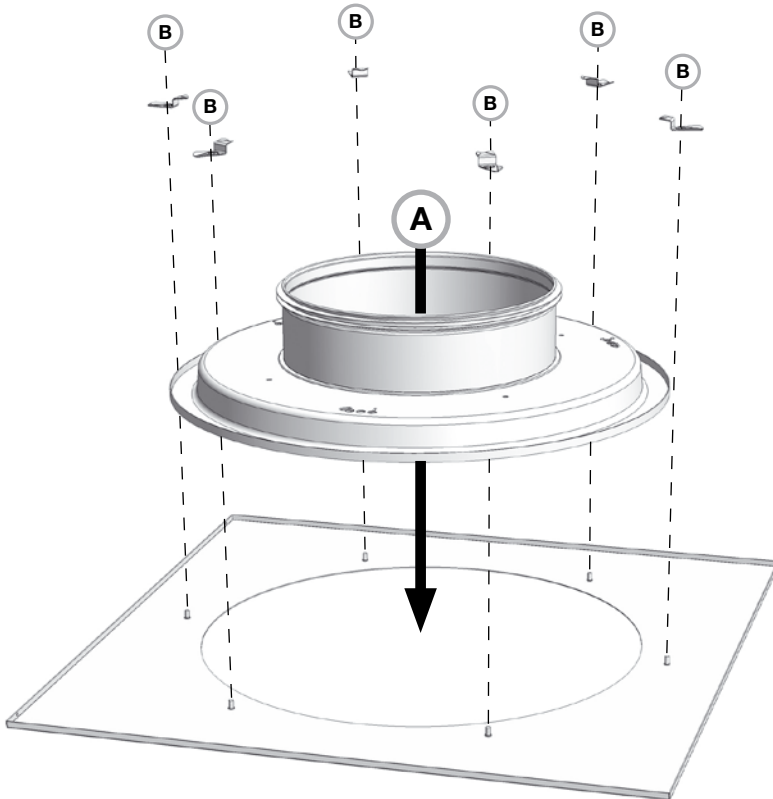
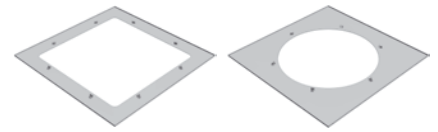

!

UK - LM module plates adapted to ceiling system 1 - 21
DK - LM modulplader tilpasset loftsystem 1 - 21
SE - LM modulramar anpassat till undertakssystem 1 - 21
FI - LM module plates adapted to ceiling system 1 - 21 - FIN
DE - LM Modulplatten angepasst für Deckensysteme 1-21
IT - La cornice LM è adatta per sistemi di controsoffitto tipo 1 - 21
RU - LM module plates adapted to ceiling system 1 - 21 - RUS
 Plaque d'habillage LM adaptées aux systèmes de plafond 1 - 21

LM PKA, LKA, PCA, LCA

PKA, LKA PCA, LCA

! CRL ~~LM~~ **!**

LM — **aa** — **bbb** — **ccc**

1-21 PKA
 Ceiling system / Loftsystem LKA
 Undertakssystem / Kattojärjestelmät PCA
 Deckensysteme LCA
 Sistemi di controsoffitto
 Потолочные системы
 Type de plafond Ød



Formo

LM

Accessories

Tilbehør

Tillbehör

Lisävarusteet

Zubehör

Accessori

Аксессуары

Accessoires

- Mounting of diffuser in ceiling with LM module plate**
- Montering af armatur i loft med LM modulplade**
- Montering av don i tak med LM modulram**
- Mounting of diffuser in ceiling with LM module plate-FIN**
- Montage des Durchlasses in der Decke mit LM Modulplatte**
- Montaggio del diffusore nel controsoffitto usando la cornice LM**
- Mounting of diffuser in ceiling with LM module plate -RUS**
- Montage du diffuseur dans le plafond avec plaque d'habillage LM**

LM

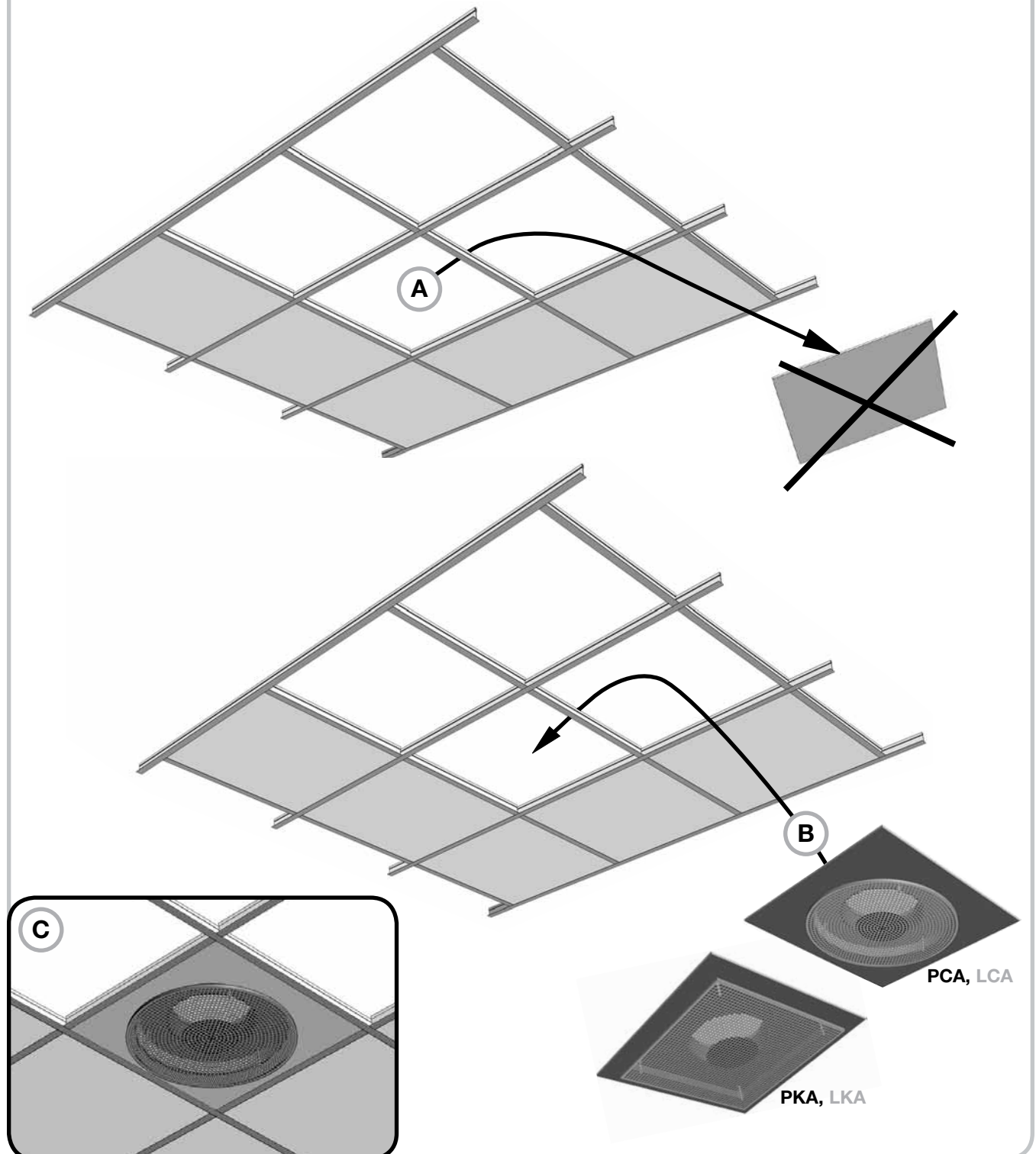
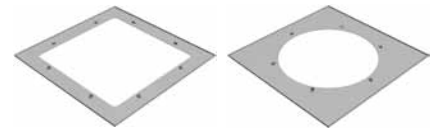



Formo

LM

Accessories

Tilbehør

Tillbehör

Lisävarusteet

Zubehör

Accessori

Аксессуары

Accessoires

- Mounting of diffuser + MBB in ceiling with LM module plate**
- Montering af armatur + MBB i loft med LM modulplade**
- Montering av don + MBB i tak med LM modulram**
- Mounting of diffuser + MBB in ceiling with LM module plate-FIN**
- Montage des Durchlasses + MBB in der Decke mit LM Modulplatte**
- Montaggio del diffusore + MBB in controsoffitto con cornice LM**
- Mounting of diffuser + MBB in ceiling with LM module plate -RUS**
- Montage du diffuseur + MBB dans le plafond avec plaque d'habillage LM**

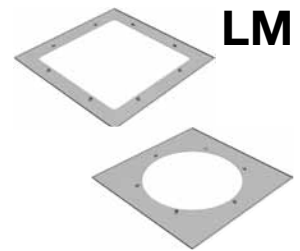

!

UK - The MBB must shortly be lifted - Otherwise see next page
DK - MBB boksen må et øjeblik løftes - Ellers se næste side
SE - The MBB must shotly be lifted - Otherwise see next page
FI - The MBB must shotly be lifted - Otherwise see next page
DE - Der MBB muss kurzzeitig nach oben gedrückt werden -
 Sonst siehe nächste Seite
IT - MBB deve essere sollevabile - in caso contrario vedere
 pagina seguente
RU - The MBB must shotly be lifted - Otherwise see next page
FR - Le MBB doit être légèrement surélevé - alternative voir page
 suivante

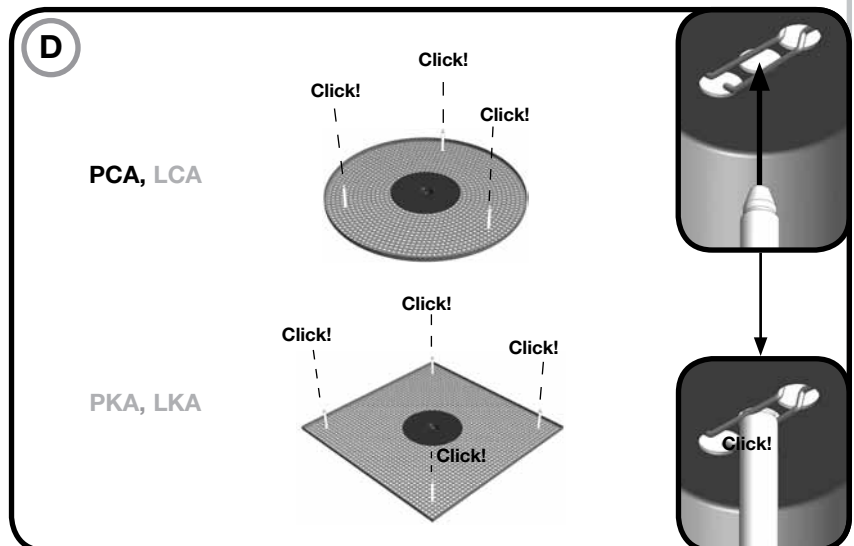
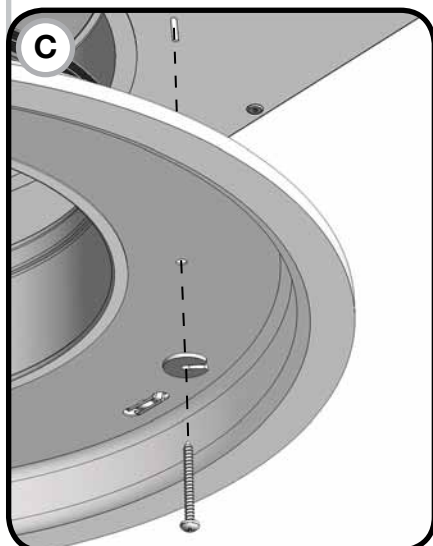
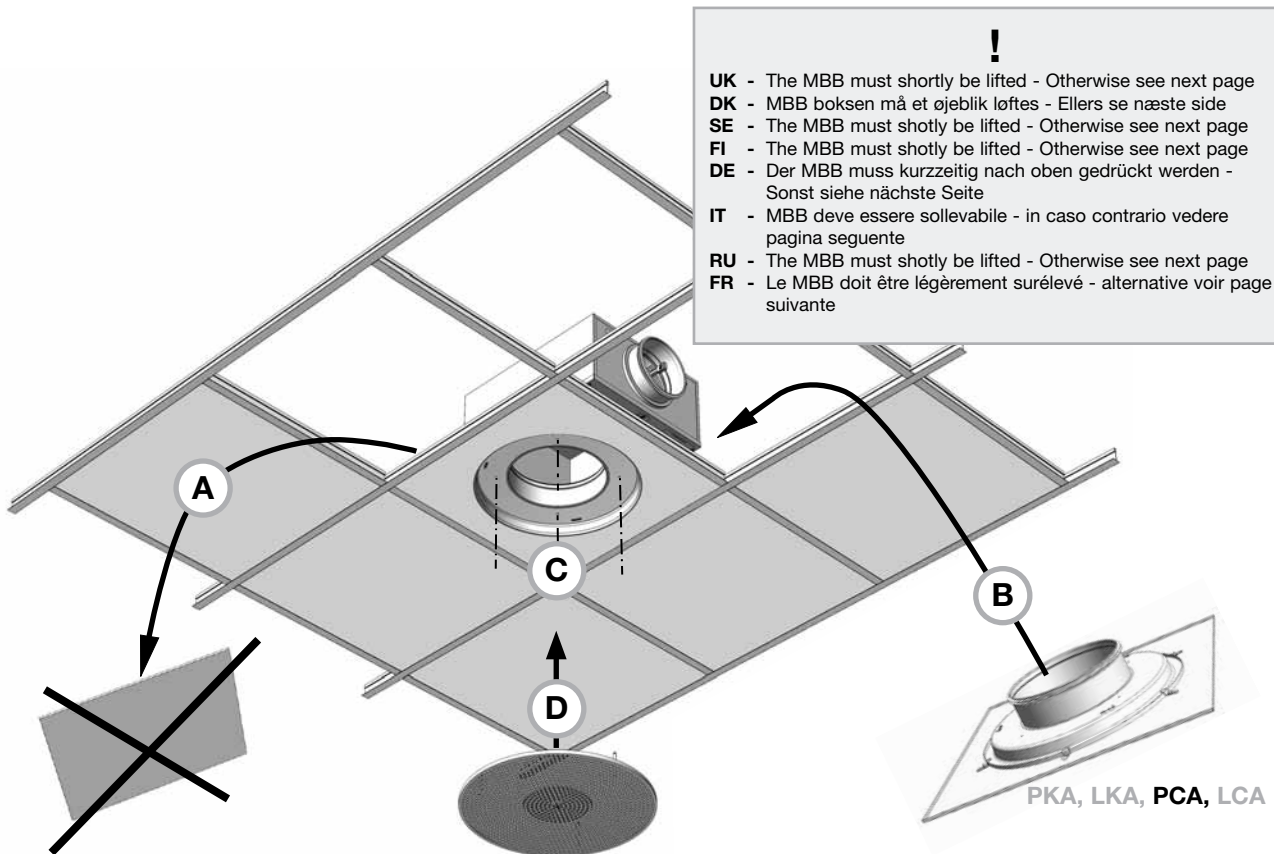



Formo

LM

Accessories

Tilbehør

Tillbehör

Lisävarusteet

Zubehör

Accessori

Аксессуары

Accessoires

Mounting of diffuser + MBB in ceiling with LM module plate
Montering af armatur + MBB i loft med LM modulplade
Montering av don + MBB i tak med LM modulram
Mounting of diffuser + MBB in ceiling with LM module plate-FIN
Montage des Durchlasses + MBB in der Decke mit LM Modulplatte
Montaggio del diffusore + MBB in controsoffitto con cornice LM
Mounting of diffuser + MBB in ceiling with LM module plate -RUS
Montage du diffuseur + MBB dans le plafond avec plaque d'habillage LM

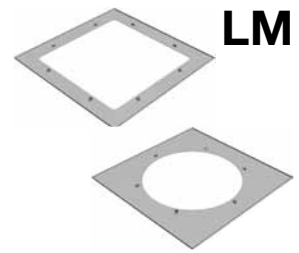

- UK** - Not enough space above suspended ceiling when mounting MBB + LM - Remove one T-runner while mounting
DK - For lidt plads over nedsænket loft ved montage af MBB + LM - Fjern en loft-skinne under montage
SE - Not enough space above suspended ceiling when mounting MBB + LM - Remove one T-runner while mounting -SWE
UK - Not enough space above suspended ceiling when mounting MBB + LM - Remove one T-runner while mounting -FIN
DE - Wenig Platz im Deckenhohlraum bei Montage MBB + LM - Entfernen Sie einen T-Träger für die Montage
IT - In caso non vi sia spazio in fase di montaggio dell'MBB + LM - Smontare una barra a T
FR - Pas assez de place dans le plafond lors du montage de MBB + LM - Retirer un support en T pendant le montage

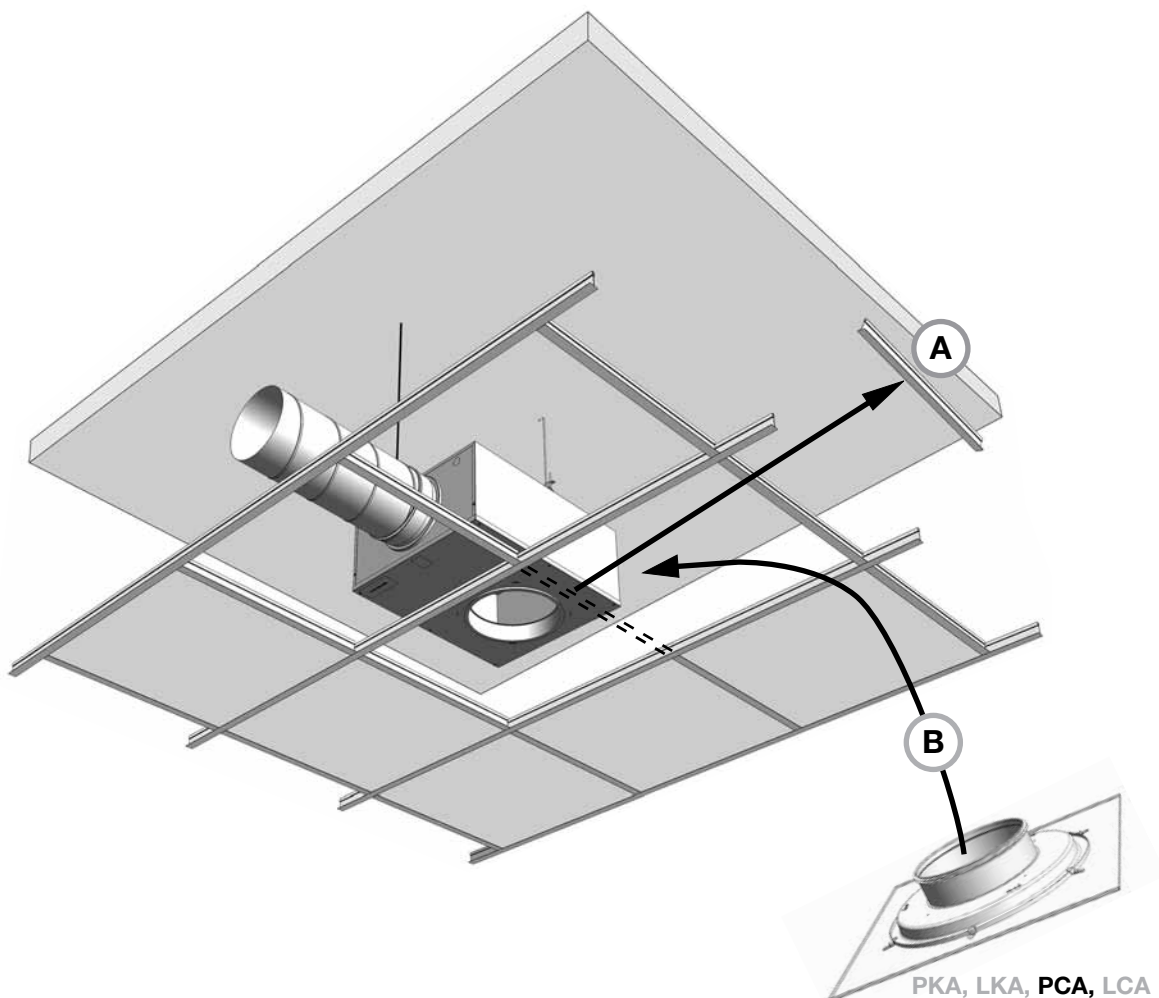



Formo

LM

Overview - LM Oversigt - LM Översikt - LM Yleiskatsaus - LM Übersicht - LM Panoramica - LM Обзор -LM Aperçu - LM

Overview LM module plates
Oversigt LM modulplader
Översikt LM Modulamar
Yleiskatsaus LM Moduulilevy
Übersicht LM Modulplatten
Panoramica LM Piastra modulare per controsoffiti
Обзор LM
Aperçu plaques d'habillage LM

! **LM**

UK - LM module plate adapted to ceiling system 1 - 21
 DK - LM modulplader tilpasset loftsystem 1 - 21
 SE - LM modulamar anpassat till undertakssystem 1 - 21
 FI - LM module plate adapted to ceiling system 1 - 21 _FIN
 DE - LM Modulplatten angepasst für Deckensysteme 1-21
 IT - La cornice LM è adatta per sistemi di controsoffitto tipo 1 - 21
 RU - LM module plate adapted to ceiling system 1 - 21 - RUS
 Plaques d'habillage LM adaptées aux systèmes de plafond 1 - 21

1, 21

1. = 600 x 600
 21.= 625 x 625

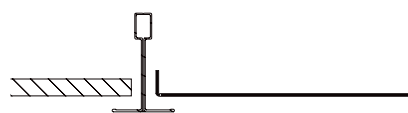

4, 5, 6

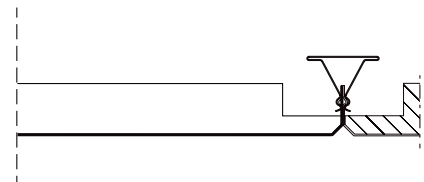
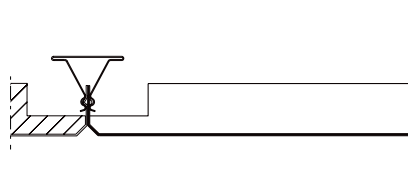

7, 8

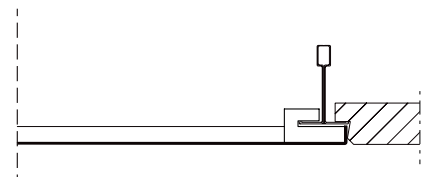
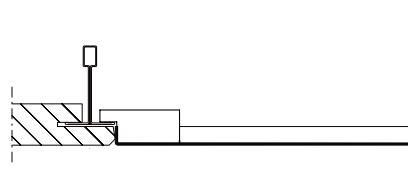

9, 10

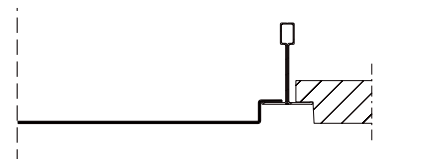
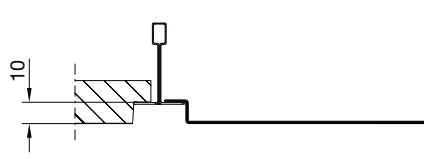

11

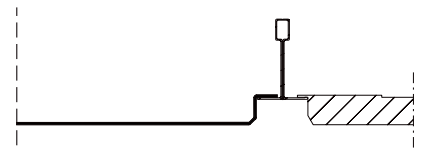
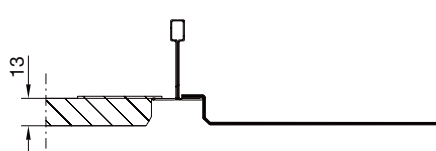

14

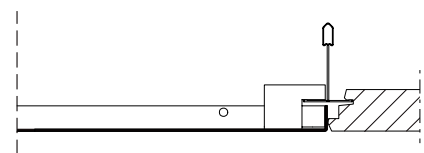
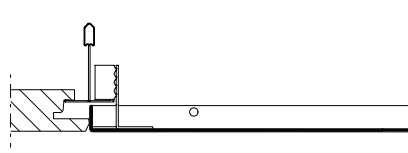



Formo

Overview

Oversigt

Översikt

Yleiskatsaus

Übersicht

Panoramica

Обзор

Aperçu

Overview - Ceiling systems

Oversigt - loftsystemer

Översikt - Undertakssystem

Yleiskatsaus - Kattojärjestelmät

Übersicht - Deckensysteme

Panoramica - Sistemi di controsoffitto

Обзор - Потолочные системы

Aperçu - Systèmes de plafond

1.
21.

T24/T15 = 600 x 600
22 = 625 x 625

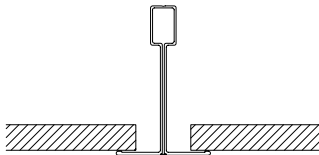

3.

Permanent ceiling
Fast loft / Fast undertak
Kiinteä alakatto
Geschlossene Decke
Soffitto permanente
Сплошной потолок
Plafond non démontable



4.

Dampa Clip-in

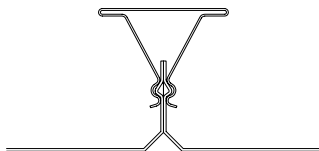

5.

Dampa Clip-in

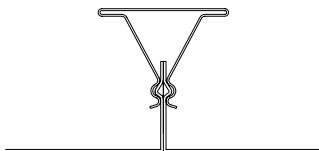

6.

Luxalon Clip-in

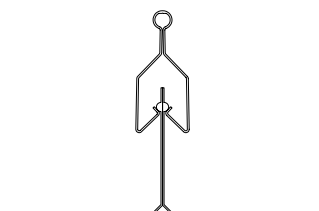

7.

Danotile Contur / Ecophon D
Rockfon D-XL

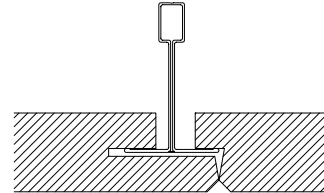

8.

Ecophon Focus DG

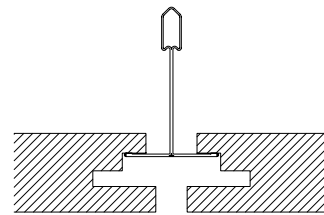

9.

Rockfon E10 24 / Ecophon E / T24

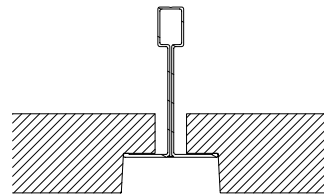

10.

Rockfon E10 15 / Ecophon E / T15

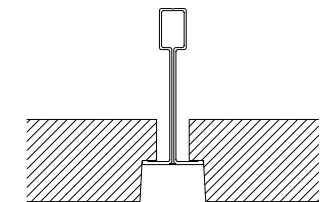

11.

Danotile Markant

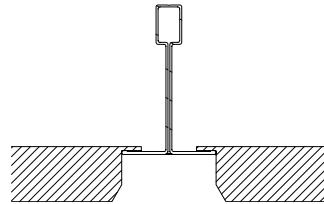

14.

Ecophon Focus DS

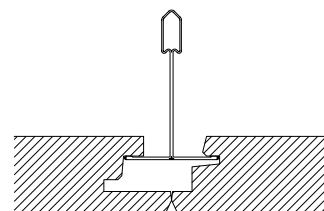

Support
Hjælp
Hjälp
Tuotetuki
Unterstützung
Supporto
Помощь
Support

UK - Here you can find product updates/mounting instructions and support telephone number/mail.

www.lindab.com

Right to alterations reserved.

DK - Her kan du finde seneste produkt opdateringer/ montagevejledninger samt support tlf. nr/mail.

www.lindab.dk

Ret til ændringer forbeholdes.

SE - Här kan du alltid hitta senaste produktuppdateringarna/montageanvisningarna samt support tel. /e-mail.

www.lindab.se

Rätt till ändringar förbehålles.

FI - Täältä löydät uusimmat tuotetiedot ja asennusohjeet sekä tuotetuen yhteystiedot.

www.lindab.fi

Oikeus muutoksiin pidätetään.

DE - Hier finden Sie aktuelle Produktinformationen/ Montageanleitungen und Telefonnummer/ E-Mail-Adressen der Ansprechpartner.

www.lindab.de

Änderungen vorbehalten.

IT - Qui potete trovare istruzioni di montaggio, informazioni sul prodotto ed un supporto tecnico qualificato
Tel. 011 9952099 - e-mail: lindab@lindab.it

www.lindab.it

Soggetto a modifica senza obbligo di preavviso.

RU - Здесь вы можете найти обновления изделия/ инструкции по монтажу и техн. поддержку по тел. / электронной почте.

www.lindab.ru

Сохраняется право на внесение изменений

FR - Vous trouverez les fiches produits ou de montage actualisées ainsi que les coordonnées du support téléphonique à l'adresse suivante :

www.lindab.fr

Toutes modifications réservées.

**Do you have trouble finding your local contacts
please go to:**

www.lindabcomfort.com

FORMO-13102011



www.lindabcomfort.com