

# Damper with flow meter

DIRU

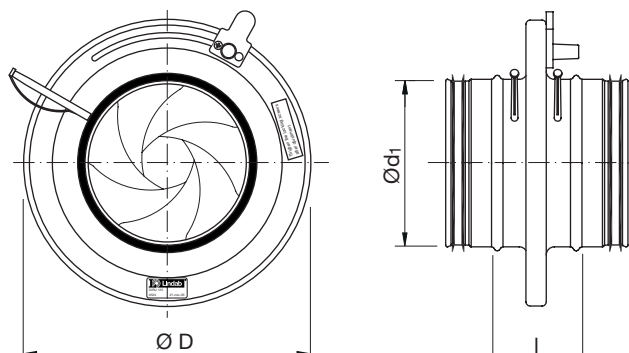

## Dimensions



## Description

The damper DIRU with flow meter offers measurement of the air flow. DIRU has the following characteristics: low noise level, centric flow, fixed measurement nozzles for accurate flow measurement and is equipped with regulating facilities that can be fully opened, which means that you do not need cleaning covers. It fulfils tightness class C.

The dimension graph is to be used to determine the pressure drop over the damper with flow meter and to give information regarding the sound effect level at different settings. When balancing the system the balancing graph should be used.

There is a separate assembly, measuring, balancing and maintenance instruction for dampers with flow meter.

The damper blades forms a measuring flange which allows flow measuring. By measuring the pressure difference between the measure nozzles, you can through the equation on the damper derive the flow  $q$  [l/s]. The setting value of the damper and the correction factor (k-factor) is the same number which means that you do not have to read a graph in order to get the k-factor from a setting value.

The air flow is regulated with a handle.

Ø 80–250 fullfills pressure class A in closed position.

### Material

The damper is made of hot-dip galvanized sheet steel.

### Installation

Consider required straight distance after or before disturbance, as mentioned on the card attached to the measurement nozzles, to obtain accurate flow measurement.

### Cleaning

By fully open the damper, one get access to the duct. Do not forget to readjust the damper after cleaning.

Ød <sub>1</sub> nom	ØD mm	l mm	m kg
100	163	54	0,80
125	210	63	1,20
160	230	60	1,40
200	285	62	2,00
250	333	62	2,60

## Order code

Product	DIRU	160
Dimension Ød <sub>1</sub>		

