

# Bend

# BU 90°

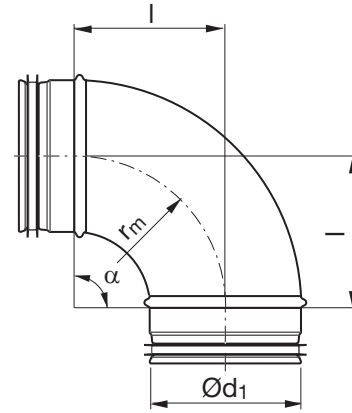

## Dimensions



$r_m \approx 1 \cdot d_1$

## Description

Pressed and seam welded bend.

Ød <sub>1</sub> nom	l mm	m kg
80	105	0,26
100	100	0,31
125	125	0,48
160	160	0,62
180	180	1,02
200	200	1,12
224	225	1,33
250	242	1,77
315 *	315	3,00

\* Segmented and lockseamed

## Order code

