

Bend

BUSS 90°

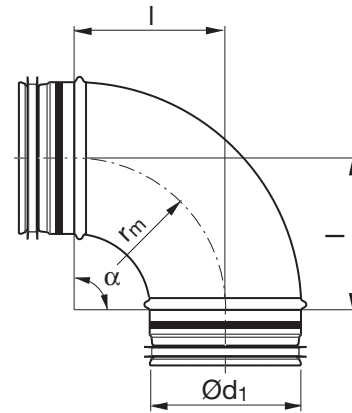

Dimensions



$$r_m \approx 1 \cdot d_1$$

Description

Pressed and seam welded bend.

The product is CE marked according to EN 12101-7 and used in a circular smoke control system - single compartment (see declaration of performance).

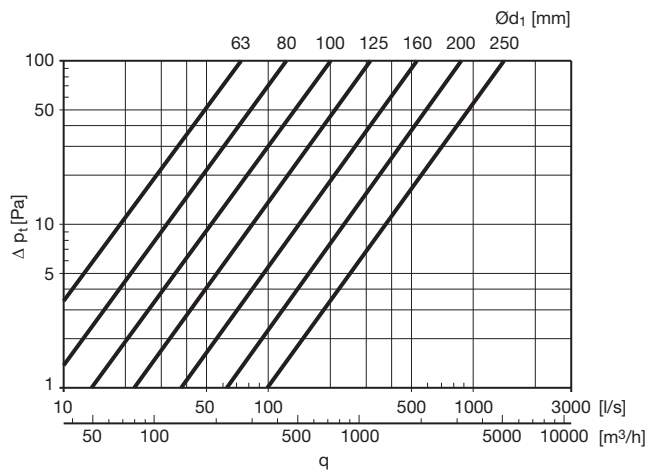

$\text{O}d_1$ nom	l mm	m kg
100	100	0,31
112	120	0,39
125	125	0,48
140	140	0,66
150	150	0,66
160	160	0,62
180	180	1,02
200	200	1,12
224	225	1,33
250	242	1,77

Ordering example

