

Cabin unit

HPB



Description

HPB is a Cabin Unit specially designed for use in high pressure systems where high flexibility has to be combined with minimum installation space. An internal scale makes it possible to preadjust the flow in order to minimize commissioning costs and document settings.

The matching diffuser HPBDC allows the user to adjust the flow within a preadjusted range.

- Adjustable damper with scale for required flowlevel-setting.
- Low noise level even at pressure above 1000 Pa.
- Flow range from 50 to 350 m³/h.
- Easy mounting with prefitted brackets.
- Excellent air distribution.
- Diffuser and inlet take off fitted with Lindab Safe rubber gasket for perfect tightness and low noise generation.
- User adjustable flow within the min./max. flow range.
- Adjustable mounting of diffuser for perfect fitting in ceiling.
- Low weight.

Maintenance

Faceplate can be removed without tools to enable cleaning of internal parts or to gain access to the box. The visible parts of the diffuser can be wiped with a damp cloth. Box can be opened for cleaning.

Diffuser for CabinUnit is ordered separately.

Ordering example

Product	HPB	100
Size		

Dimensions

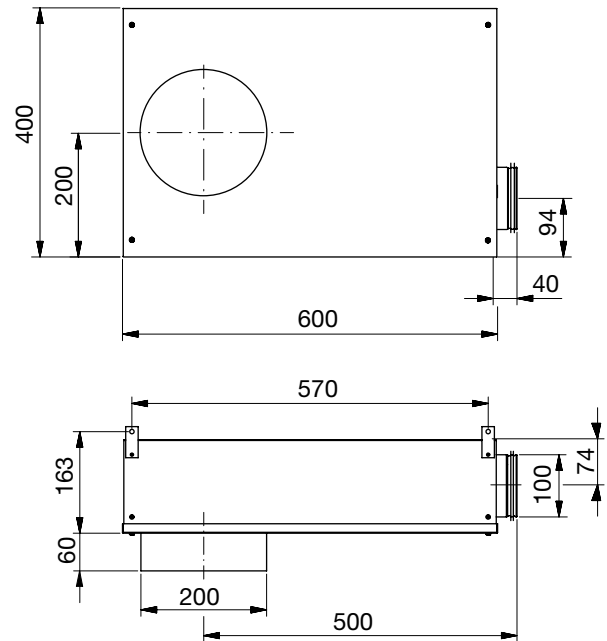

Options

- Electrical heating element. 230V AC with selectable effects of 250, 500 or 1000 Watt.
- Integrated thermostat with selectable operating temperature between 30-110° C.
- Manual safety switch cuts off electricity if the temperature exceeds 113° C
- Non-combustible mineral wool insulation
- External room thermostat

Materials and finish

Material: Galvanised steel.

Insulation: Non-flammable melamine foam plastic.

Please contact Lindab sales department for further information