

Bend

BSTR 60°



Description

Pressed and seam welded bend.

Dimensions

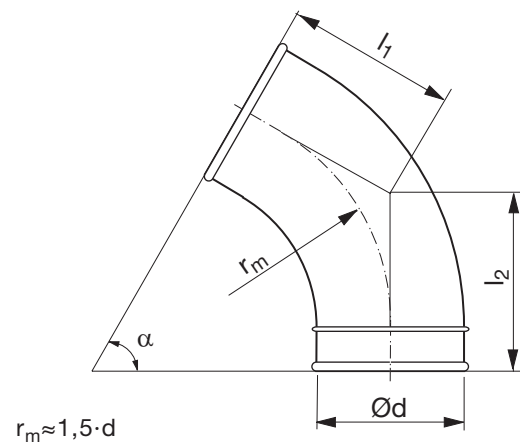

| Ød nom | t [mm] | r _m [mm] | l ₁ [mm] | l ₂ [mm] | m [kg] |
|-----------|-----------|------------------------|------------------------|------------------------|-----------|
| 100 * | 0,6 | 150 | 117 | 143 | 0,40 |
| 125 * | 0,7 | 190 | 140 | 166 | 0,60 |
| 150 * | 0,7 | 225 | 160 | 186 | 0,70 |
| 160 * | 0,7 | 240 | 169 | 195 | 0,80 |
| 180 * | 0,7 | 270 | 181 | 208 | 1,20 |
| 200 ** | 0,7 | 300 | 225 | 225 | 1,13 |

* 1 swaged-on end

** 2 swaged-on ends

Ordering example

| | | | |
|--------------|-------------|------------|-----------|
| | BSTR | 200 | 60 |
| Product | | | |
| Dimension Ød | | | |
| Angle α | | | |