

Bend

BSTR 15°



Description

Pressed and seam welded bend.

Dimensions

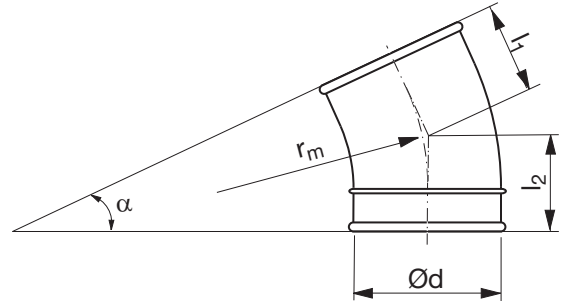

$$r_m \approx 1,5 \cdot d$$

Ød nom	t [mm]	r _m [mm]	l ₁ [mm]	l ₂ [mm]	m [kg]
100 *	0,6	150	50	76	0,20
125 *	0,7	190	55	81	0,40
150 *	0,7	225	60	86	0,40
160 *	0,7	240	62	88	0,40
180 *	0,7	270	61	88	0,50
200 **	0,7	300	91	91	0,62

* 1 swaged-on end

** 2 swaged-on ends

Ordering example

