

Installation booklet  
English

CIRCULAR SERIES WH25 - 500 Pa

Cert. N° 1812-CPR-1023 EN 15650

\*1MUBWH25UEN-LIND\* rev 19-05



[www.lindab.com](http://www.lindab.com) - Fire dampers are manufactured by MP3 Srl [www.mp3-italia.it](http://www.mp3-italia.it)

For further information please refer to the Technical Manual.

As the manufacturer is constantly improving its products, the aesthetic or dimensional features, the technical data, the equipment and accessories indicated could be subject to variations.

This is a 23 page installation booklet.

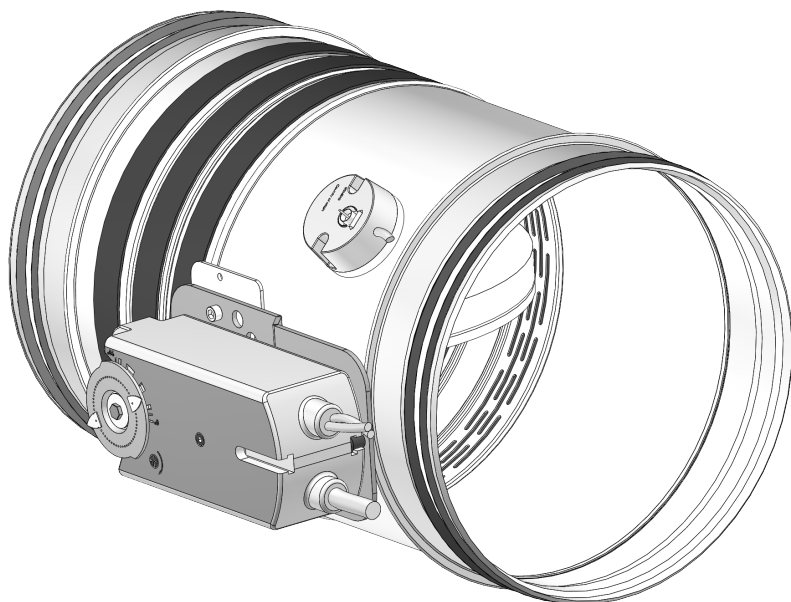

# OVERVIEW

## ■ Mechanism type

### ■ Manual and compact manual

#### Manual

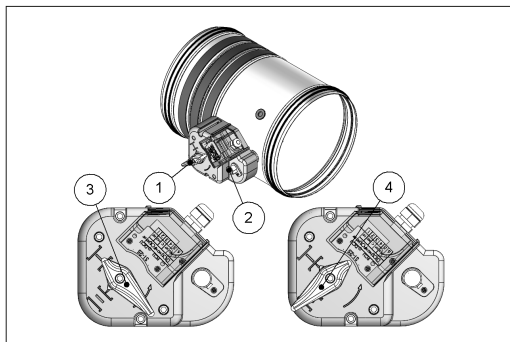

#### Compact manual

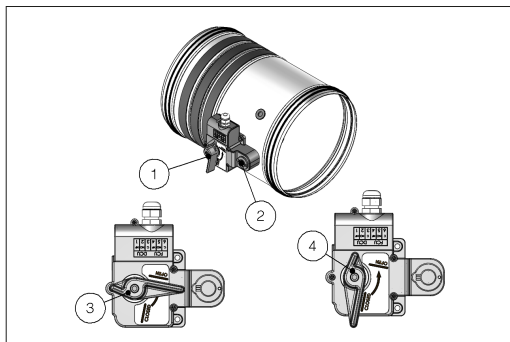

1. Manual opening lever
2. Manual closing button
3. Lever position when the blade is open
4. Lever position when the blade is closed

#### Blade closing mode

Automatic closing with thermal fuse.

The control mechanism has a thermosensitive element that automatically closes the blade when the temperature in the duct exceeds 70°C (or 95°C for the fire damper with 95°C thermal fuse).

It is possible to close the damper by pressing the indicated button.

#### Blade opening mode

The damper must be opened when the ventilation system is switched off.

It is possible to open the damper blade by rotating the lever anticlockwise.

In case of closed damper as a result of the action of the thermosensitive element, it is possible to manually reopen the damper by rotating the lever counterclockwise once the element has been replaced.

#### Position indication microswitches

On request, the fire damper can be supplied with position microswitches (S2 optional) that signal the blade position (open or closed). Refer to the section Electrical connections for more details.

#### Closing by remote control

Not available

#### Temperature calibration of thermosensitive element for automatic damper closing

70 °C±7 °C (Standard)

95 °C±9 °C (On request).

**CAUTION: The compact mechanism is not interchangeable with other types of manual mechanism.**

### ■ Manual with magnet

1. Manual opening lever
2. Manual closing button
3. Lever position when the blade is open
4. Lever position when the blade is closed

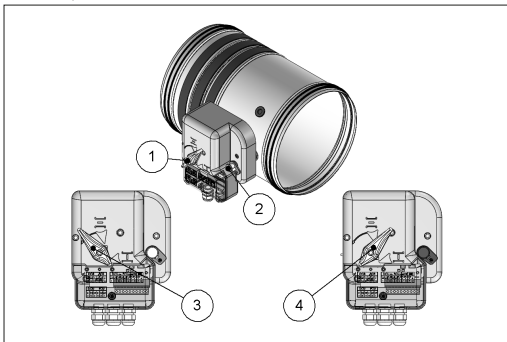

#### Blade closing mode

Automatic closing with thermal fuse.

The control mechanism has a thermosensitive element that automatically closes the blade when the temperature in the duct exceeds 70°C (or 95°C for the fire damper with 95°C thermal fuse).

It is possible to close the damper by pressing the indicated button.

It is possible to remotely close the fire damper.

The manual command mechanism with magnet is equipped with an electromagnet which, in case power is interrupted (interruption magnet version) or when power is supplied (input magnet version), commands the closing of the damper.

#### Blade opening mode

The damper must be opened when the ventilation system is switched off.

In case of closed damper by pressing the closing button or remotely by electromagnet, it is possible to manually open the fire damper blade by rotating the lever anticlockwise.

In case of closed damper as a result of the action of the thermosensitive element, it is possible to manually reopen the damper by rotating the lever counterclockwise once the element has been replaced.

#### Position indication microswitches

It is advisable to install the fire damper with position microswitches (S2 optional) which signal the position of the blade (open or closed). Refer to the section Electrical connections for more details.

#### Closing by remote control

With power supply input or interruption magnet.

#### Temperature calibration of thermosensitive element for automatic damper closing

70 °C±7 °C (Standard)

95 °C±9 °C (On request).

#### ■ Belimo motorized version

1. Manual closing switch
2. Manual opening lever
3. Position indicator
4. Blade locking lever

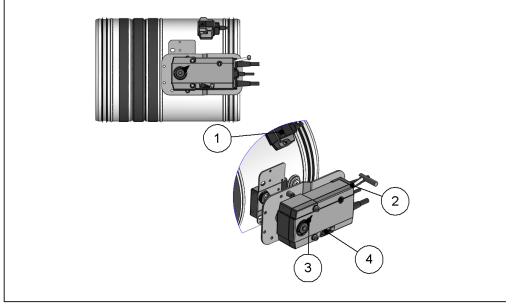

#### Blade closing mode

Automatic closing with thermal fuse.

The WH25VPB/DPB control mechanism has a thermosensitive element that automatically closes the blade when the temperature in the duct or in the room exceeds 72°C (or 95°C for the 95°C version). To close the damper when the motor is connected, press the switch on the temperature sensor or cut off the power supply.

#### Blade opening mode

The damper must be opened when the ventilation system if switched off.

To open the damper with the electric motor driven actuator, provide power supply to the motor. Refer to the section Electrical connections for further information.

To manually open the damper, use the handle supplied and carefully rotate clockwise to the 90° indicator. To hold the damper in open position operate on the lever indicated in figure.

During the manual opening of the damper, power must not be supplied to the motor.

#### Position indication microswitches

The motorized versions are supplied with two microswitches to show the blade's position (open or closed). Refer to the section Electrical connections for further information.

#### Closing by remote control

If power to the motor is cut off, the blade will close.

#### Temperature calibration of thermosensitive element for automatic damper closing

72 °C±7 °C (Standard)

95 °C±9 °C (On request).

#### ■ Siemens motorized version

1. Manual closing switch
2. Manual opening lever
3. Screwdriver
4. Position indicator

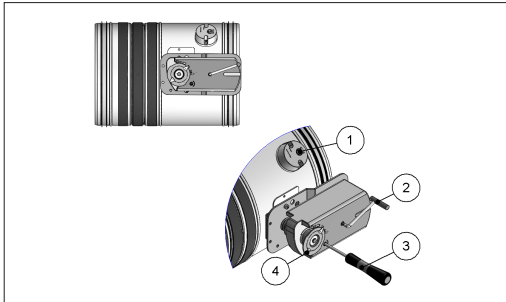

#### Blade closing mode

Automatic closing with thermal fuse.

The control mechanism has a thermosensitive element that automatically closes the blade when the temperature in the duct or in the room exceeds 72°C (or 95°C for the 95°C version).

To close the damper when the motor is connected, press the switch on the temperature sensor or cut off the power supply.

#### Blade opening mode

The damper must be opened when the ventilation system if switched off.

To open the damper with the electric motor driven actuator, provide power supply to the motor. Refer to the section Electrical connections for further information.

To manually open the damper, use the handle supplied and carefully rotate counterclockwise to the 90° indicator. To hold the damper in open position, rotate the screw anticlockwise as shown in the picture.

During the manual opening of the damper, power must not be supplied to the motor.

#### Position indication microswitches

The motorized versions are supplied with two microswitches to show the blade's position (open or closed). Refer to the section Electrical connections for further information.

#### Closing by remote control

If power to the motor is cut off, the blade will close.

#### Temperature calibration of thermosensitive element for automatic damper closing

72 °C±7 °C (Standard)

95 °C±9 °C (On request).

		EI 120 S (500 Pa)	EI 90 S (500 Pa)	EI 60 S (500 Pa)	EI 30 S (500 Pa)
Rigid wall	EI 120 S Installation within vertical rigid wall				
	Wall minimum thickness 100 mm Wall minimum density 550 kg/m <sup>3</sup> Mortar or plaster putty sealing ve (i↔o)	W	∅ min 100 max 315	∅ min 100 max 315	∅ min 100 max 315
	EI 90 S Installation within vertical rigid wall				
	Wall minimum thickness 100 mm Wall minimum density 550 kg/m <sup>3</sup> Plasterboard and rock wool 100 kg/m <sup>3</sup> sealing ve (i↔o)	D	-	∅ min 100 max 315	∅ min 100 max 315
Flexible wall	EI 60 S Installation within vertical light wall (plasterboard)				
	Wall minimum thickness 100 mm Wall rock wool density up to 80 kg/m <sup>3</sup> (optional) Plasterboard and rock wool 80 kg/m <sup>3</sup> density sealing ve (i↔o)	D	-	∅ min 100 max 315	∅ min 100 max 315
	EI 90 S Installation within vertical light wall (plasterboard)				
	Wall minimum thickness 100 mm Wall rock wool density up to 80 kg/m <sup>3</sup> (optional) Plasterboard and rock wool 100 kg/m <sup>3</sup> density sealing ve (i↔o)	D	-	∅ min 100 max 315	∅ min 100 max 315
	EI 120 S Installation within vertical light wall (plasterboard)				
	Wall minimum thickness 100 mm Wall rock wool density up to 80 kg/m <sup>3</sup> (optional) Mortar or plaster putty sealing ve (i↔o)	W	∅ min 100 max 315	∅ min 100 max 315	∅ min 100 max 315
Floor	EI 90 S Installation within vertical light wall (gypsum blocks wall)				
	Wall minimum thickness 70 mm Wall minimum density 995 kg/m <sup>3</sup> Plaster putty sealing ve (i↔o)	W	-	∅ min 100 max 315	∅ min 100 max 315
	EI 120 S Installation within vertical light wall (gypsum blocks wall)				
	Wall minimum thickness 100 mm Wall minimum density 995 kg/m <sup>3</sup> Plaster putty sealing ve (i↔o)	W	∅ min 100 max 315	∅ min 100 max 315	∅ min 100 max 315
Floor	EI 90 S Installation within floor				
	Floor minimum thickness 100 mm Floor minimum density 650 kg/m <sup>3</sup> Mortar sealing ho (i↔o)	W	-	∅ min 100 max 315	∅ min 100 max 315
Floor	EI 120 S Installation within floor				
	Floor minimum thickness 150 mm Floor minimum density 650 kg/m <sup>3</sup> Mortar sealing ho (i↔o)	W	∅ min 100 max 315	∅ min 100 max 315	∅ min 100 max 315

∅ is the minimum and maximum nominal diameter of fire dampers in mm

- ve Vertical installation
- ho Horizontal installation
- (i↔o) Origin of fire irrelevant
- Pa Pascal of depression
- E Integrity
- I Thermal insulation
- S Smoke seal
- W Wet method sealing
- D Dry method sealing

Cert. N° 1812-CPR-1023 EN 15650

■ Fire Batt (Weichschott) sealings

		EI 120 S (300 Pa)	EI 90 S (300 Pa)	EI 60 S (300 Pa)	EI 30 S (300 Pa)
EI 120 S Installation within vertical rigid wall with Fire Batt (Weichschott) sealing					
Rigid wall	Wall minimum thickness 100 mm Wall minimum density 550 kg/m <sup>3</sup> Rock wool 140 kg/m <sup>3</sup> and endothermic varnish sealing ve (↔→○)	W Ø min 100 max 315	Ø min 100 max 315	Ø min 100 max 315	Ø min 100 max 315
	Minimum distance allowed between 2 dampers	200 mm	50 mm	50 mm	50 mm
EI 120 S Installation within vertical light wall (plasterboard) with Fire Batt (Weichschott) sealing					
Flexible wall	Wall minimum thickness 100 mm Wall rock wool density up to 80 kg/m <sup>3</sup> (optional) Rock wool density 140 kg/m <sup>3</sup> and endothermic varnish sealing ve (↔→○)	W Ø min 100 max 315	Ø min 100 max 315	Ø min 100 max 315	Ø min 100 max 315
	Minimum distance allowed between 2 dampers	200 mm	50 mm	50 mm	50 mm
EI 120 S Installation within vertical light wall (gypsum blocks wall) with Fire Batt (Weichschott) sealing					
Flexible wall	Wall minimum thickness 100 mm Wall minimum density 995 kg/m <sup>3</sup> Rock wool 140 kg/m <sup>3</sup> and endothermic varnish sealing ve (↔→○)	W Ø min 100 max 315	Ø min 100 max 315	Ø min 100 max 315	Ø min 100 max 315
	Minimum distance allowed between 2 dampers	200 mm	50 mm	50 mm	50 mm
EI 90 S Installation within floor and Fire Batt (Weichschott) sealing					
Floor	Floor minimum thickness 150 mm Floor minimum density 650 kg/m <sup>3</sup> Rock wool 140 kg/m <sup>3</sup> and endothermic varnish sealing ho (↔→○)	W -	Ø min 100 max 315	Ø min 100 max 315	Ø min 100 max 315
	Minimum distance allowed between 2 dampers	-	200 mm	200 mm	200 mm

■ Installation remote from construction support

		EI 120 S (300 Pa)	EI 90 S (500 Pa)	EI 60 S (500 Pa)	EI 30 S (500 Pa)
Rigid wall	EI 120 S Installation remote from the vertical rigid wall				
	Wall minimum thickness 100 mm Wall minimum density 550 kg/m <sup>3</sup> Mortar or plaster putty sealing ve (↔→)	W	∅ min 100 max 315	∅ min 100 max 315	∅ min 100 max 315
	EI 120 S Installation remote from the vertical rigid wall with Fire Batt (Weichschott) sealing				
	Wall minimum thickness 100 mm Wall minimum density 550 kg/m <sup>3</sup> Rock wool 140 kg/m <sup>3</sup> and endothermic varnish sealing ve (↔→)	D	∅ min 100 max 315	∅ min 100 max 315	∅ min 100 max 315
Flexible wall	EI 120 S Installation remote from the vertical light wall (plasterboard)				
	Wall minimum thickness 100 mm Wall rock wool density up to 100 kg/m <sup>3</sup> (optional) Plasterboard and rock wool 100 kg/m <sup>3</sup> or mortar or plaster putty sealing ve (↔→)	D/W	∅ min 100 max 315	∅ min 100 max 315	∅ min 100 max 315
	EI 120 S Installation remote from the vertical light wall (plasterboard) with Fire Batt (Weichschott) sealing				
	Wall minimum thickness 100 mm Wall rock wool density up to 100 kg/m <sup>3</sup> (optional) Rock wool density 140 kg/m <sup>3</sup> and endothermic varnish sealing ve (↔→)	D	∅ min 100 max 315	∅ min 100 max 315	∅ min 100 max 315
	EI 120 S Installation remote from the vertical light wall (gypsum blocks wall)				
	Wall minimum thickness 100 mm Wall minimum density 995 kg/m <sup>3</sup> Mortar or plaster putty sealing ve (↔→)	W	∅ min 100 max 315	∅ min 100 max 315	∅ min 100 max 315
Floor	EI 120 S Installation remote from the floor				
	Floor minimum thickness 150 mm Floor minimum density 650 kg/m <sup>3</sup> Mortar or plaster putty sealing ho (↔→)	W	∅ min 100 max 315	∅ min 100 max 315	∅ min 100 max 315
	EI 90 S Installation remote from the floor				
	Floor minimum thickness 100 mm Floor minimum density 650 kg/m <sup>3</sup> Mortar or plaster putty sealing ho (↔→)	W	-	∅ min 100 max 315	∅ min 100 max 315

■ Installations within vertical light wall (Shaft wall)

		EI 90 S (300 Pa)	EI 60 S (300 Pa)	EI 30 S (300 Pa)
Flexible wall	EI 90 S Installation within vertical light wall (Shaft wall)			
	Wall minimum thickness 90 mm Plasterboard and mortar or plaster putty sealing ve (↔→)	W	∅ min 100 max 315	∅ min 100 max 315

## ELECTRICAL CONNECTIONS

■ Electrical wiring

Electrical connections must be done by qualified and trained people. Switch off the power supply before starting any work on the electric elements. Never switch on the power supply during electrical connections.

Manual and compact manual  
**S1-25 electric board (S2 optional) for blade position microswitches (manual)**

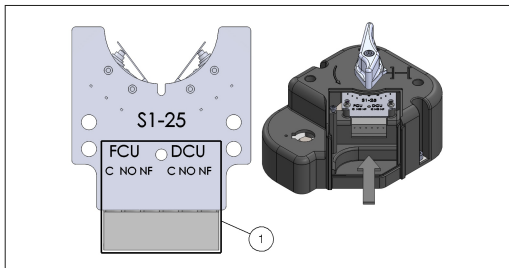

**S1-25-B electric board (S2 optional) for blade position microswitches (compact manual)**

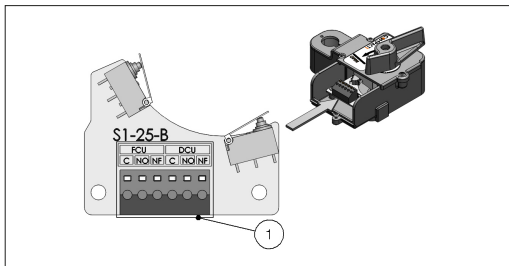

- 1 Microswitch contacts for blade position  
 FCU Closed blade contact  
 DCU Open blade contact  
 NO Normally open  
 C Common  
 NF Normally closed

Manual with magnet - MR/MI version (the magnet is powered using 24 V DC/48 V DC through S0-25 electric board)

**S0-25 electronic board (S2 optional) for 24V DC / 48V DC power supply. Blade position microswitches included**

- 1 Microswitch contacts for blade position  
 2 Magnet power supply contacts. 24V DC or 48V DC. Keep to the polarity for input magnet

- MAG Magnet power supply  
 FCU Closed blade contact  
 DCU Open blade contact  
 NO Normally open  
 C Common  
 NF Normally closed

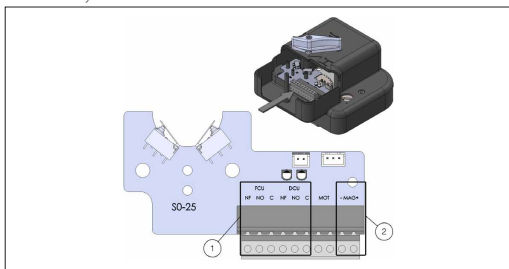

S2 microswitches position for manual control and magnetic control

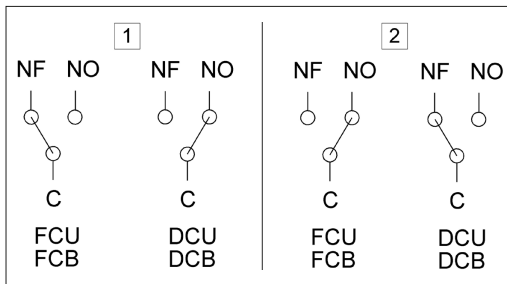

1. The fire damper's blade is open (the air flow is allowed)  
 2. The fire damper's blade is closed (the air flow is not allowed)  
 FCU Closed blade contact  
 DCU Open blade contact  
 NO Normally open  
 C Common  
 NF Normally closed

Motorized version

**Belimo servomotor:**

BFL24T, BFN24T, BF24T, BFL230T, BFN230T, BF230T.

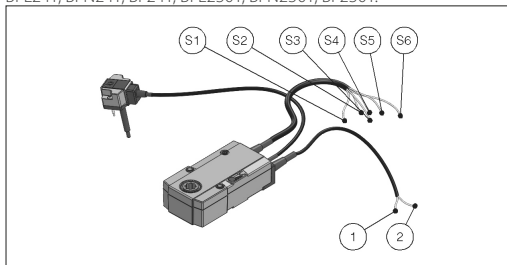

**Siemens servomotor:**

GRA126, GNA126, GGA126.

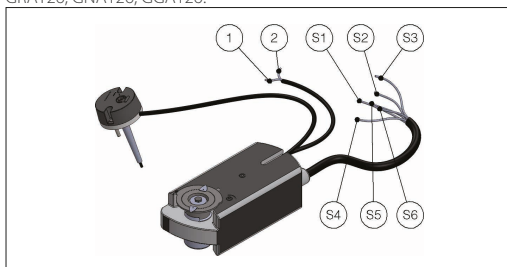

**Siemens servomotor:**

GRA326, GNA326, GGA326.

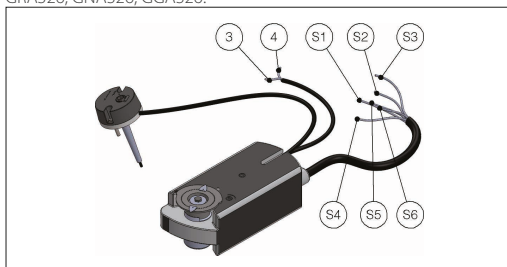

### Motorized fire dampers electrical wiring

To connect the dampers to the power supply, proceed as follows:

- Check that the voltage and electrical frequency are equivalent to those of the motor of the servomotor (check the motor's information label);
- Make the connections as shown in the below diagram.

### Microswitches position for motorized version

24V AC/DC power supply

/- Negative (DC) or neutral (AC) black wire

~/+ Positive (DC) or phase (AC) red wire

230V AC power supply

N Neutral blue wire

L Phase brown wire

Microswitches position contacts

S1 Common closed damper microswitch

S2 Normally closed, closed damper microswitch

S3 Normally opened, closed damper microswitch

S4 Common open damper microswitch

S5 Normally closed, open damper microswitch

S6 Normally opened, open damper microswitch

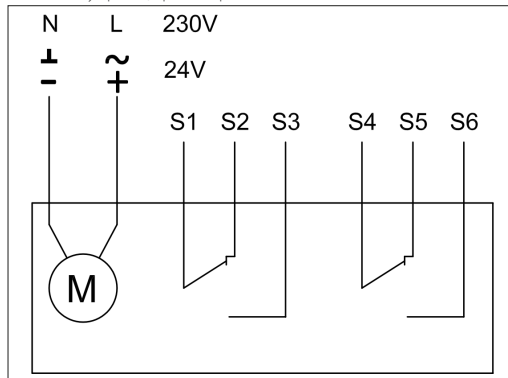

### Electrical specifications

	Manual and compact manual	Manual with magnet Belimo motorized version Siemens motorized version
Voltage and power consumption	-	<p>Magnet (WH25MR/MI): 24/48 V DC (automatic voltage switching on S0-25 electric board for 24 V magnet)</p> <p>Power interruption magnet (MR): P = 1,6 W</p> <p>Power input magnet (MI): P = 3,4 W</p> <p>Motor 24 V AC/DC (WH25VSB): Belimo BFL24T Opening: 2,5 W In stand-by: 0,8 W</p> <p>Motor 230 V AC (WH25DSB): Belimo BFL230T Opening: 3,5 W In stand-by: 1,1 W</p> <p>Motor 24 V AC/DC (WH25VSS): Siemens GRA126 Opening: 3,5 W In stand-by: 2 W</p> <p>Motor 230 V AC (WH25DSS): Siemens GRA326 Opening: 4,5 W In stand-by: 3,5 W</p>
Microswitches position contacts	Manual control version: 12 V DC / 2 A 125 V AC / 0,1 A	Motorized version: Siemens: AC 24 V...230 V / 6 (2) A Belimo: DC 5 V...AC 250 V / 1 mA...3 A (0,5 A)
Blade closing time	Spring: 1 s	motor: < 30 s
Protection degree	IP42	IP42 MAGNETIC VERSION IP54 MOTORIZED VERSION



# TECHNICAL DATA

## Dimension

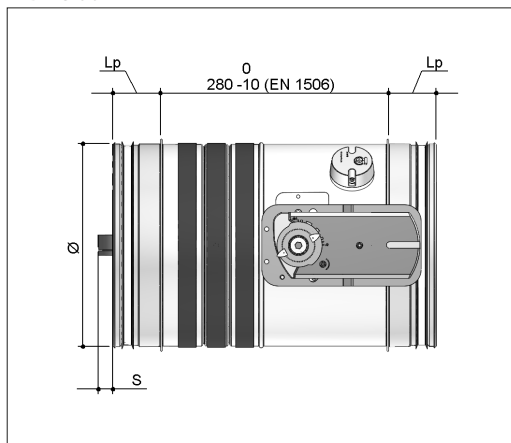

Ø	mm	100	125	140	150	160	180
S blade exposition	mm	0	0	0	0	0	0
Lp	mm	38	38	38	38	38	38
Ø	mm	200	224	250	280	300	315
S blade exposition	mm	0	1	0	10	20	28
Lp	mm	38	38	57	57	57	57

Lp Overlap length between fire damper and duct

## MAINTENANCE AND INSPECTIONS

Fire dampers and control mechanisms do not require routine maintenance.

Extraordinary maintenance (repairs) and periodic inspection operations are the responsibility of the ventilation system operator.

The implementation of a periodic inspection plan allows to guarantee the efficiency and functionality of the fire dampers for the fire safety of the building.

### Periodic inspection and cleaning

Periodic inspection shall be performed in accordance with the requirements of the law or by the building regulations or other local regulations.

In the absence of specific regulations (or to their complement), in accordance with point 8.3 of the EN 1560 standard, it is recommended to carry out the following control activities at intervals of no more than 6 months:

- If the damper is connected to a remote control or command system (eg BMS or alarm or fire detection), that responds correctly to commands by performing at least one opening and closing test and verifying the correct movement of the blade and the correct functioning of the microswitches (limit switches).
- If the damper is not connected to a remote control or command system, manually execute an opening and closing test and check the correct movement of the blade and the correct functioning of the microswitches (limit switches) if present.

Together with the control activities, it is recommended to visually verify the absence of corrosion, the integrity of the electrical wiring and the sealing of the construction support.

Damper cleaning is included in the ordinary maintenance activities of the ventilation ducts.

Fire dampers can be cleaned with a dry or wet cloth.

In the case of resistant dirt, it is possible to use normal household detergents.

If prescribed for the type of building, it is possible to use disinfectant detergents.

The use of detergents or mechanical abrasive cleaning systems is not permitted.

These indications comply with the standards EN 15650 annex D and EN 15423 annex C.

### Repair

For safety reasons, repair activities involving fire-fighting components must be carried out only by qualified personnel.

Only original spare parts supplied by the fire damper manufacturer must be used.

A functional test must be performed after each repair.

At the end of the inspection, cleaning or repair operations, check that the fire damper is in the normal operating position.

Keep records of all inspections, repair activities, any problems encountered and their resolution.

This practice, even when not mandatory, is very useful in practice.

### Disposal

Disposal in case of destruction must be carried out in accordance with national legislation. For electrical and electronic parts also refer to EU Directive 2011/65.

## INSTALLATION

The sizes shown are in mm.

It is recommended to perform a functional test before installation to exclude possible damage during transport and another test immediately after installation to exclude accidental damage to the product and interference with mounting components.

■ Positioning brackets before fixing

1. Positioning brackets

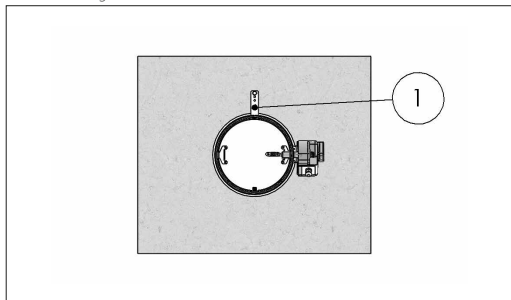

■ Blade rotation axis positioning

The fire damper can be installed with the blade axis positioned vertically or horizontally or tilted at any angle.

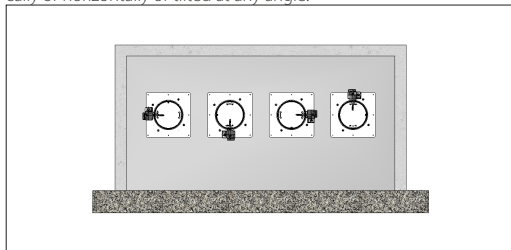

■ Installation of flexible connectors in order to balance out the ventilation ducts expansion

**CAUTION: Refer anyway to law and national standardization.** Flexible connectors compensate any duct thermal expansion and wall bending in case of fire.

Flexible connectors are used to limit fire damper stresses due to external forces in case of fire and to preserve fire resistance class.

In general it is always appropriate the use of flexible connectors for the followings installations:

- light walls;
- Plasterboard and rock wool or Fire Batt (Weichschott) sealing;
- Applique fixing system.

Flexible connector must be normal flammability and in case of fire the grounding bonding should disconnect to guarantee the complete separation between fire damper and connected air duct.

When flexible connectors made of conductive material (e.g. aluminum) are used, no additional grounding bonding is required.

Despite flexible connector installation, the fire damper must be installed in the construction support so that its weight does not affect damper's installation position both during normal operation and in case of fire.

It is recommended not to compress flexible connectors in the installation phase.

Flexible connector must be at least 100mm long and in order that possible duct thermal expansions are balanced.

Take care that the flexible connector does not interfere with opening / closing movement of the blade.

■ Transfer Application (application not connected to air ducts on one or both sides)

Following tests performed as per EN 1366-2, section 6.3.6 Standard, it is possible to install the fire damper free from air duct from one or both sides.

- Attention: fire resistance classification for transfer application is conform to section Fire resistance classification according to EN

13501-3-2009 limited to EI 120S if the ducted classification is higher.

- End cap with mesh shall be mounted on the side not connected to air duct.
- End cap with mesh is made from galvanized steel sheet.
- End cap with mesh is supplied loose from the fire damper.

■ Components (Transfer Application)

1. End cap with mesh (to fix to fire damper with steel screws)
2. Fire damper

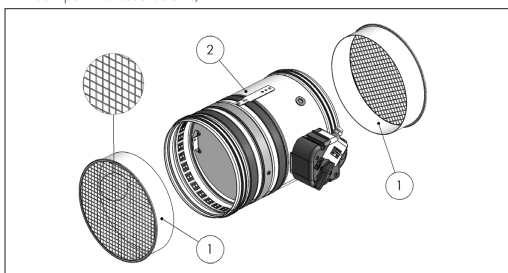

■ Technical data (Transfer Application)

1. Mechanism side
  2. Mechanism opposite side
  3. End cap with mesh
- L1 End cap length mechanism side  
L2 End cap length mechanism opposite side  
Ø Fire damper nominal diameter

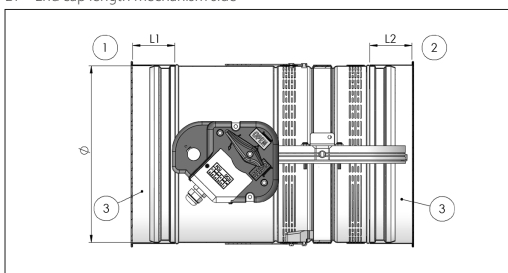

Length of end cap with mesh depending on fire damper diameter Ø.

Ø	L1	L2
100	40	40
125	40	40
140	40	40
150	40	40
160	40	40
180	40	40
200	40	60
224	40	40
250	60	80
280	60	100
300	60	100
315	60	120

- Ø Fire damper nominal diameter  
L1 End cap length mechanism side  
L2 End cap length mechanism opposite side

■ Minimum distances

It is recommended to keep enough space for using the control mechanism or for maintenance.

In accordance with Articles 7 and 13 of EN 1366-2 respect the minimum distances indicated below.

### Minimum distances

1. Side vertical wall
2. Floor
- a. Distance between fire dampers installed within vertical wall

- b. Distance between fire damper and vertical lateral wall / floor
- c. Distance between fire dampers installed within floor
- d. Distance between fire damper and vertical lateral wall

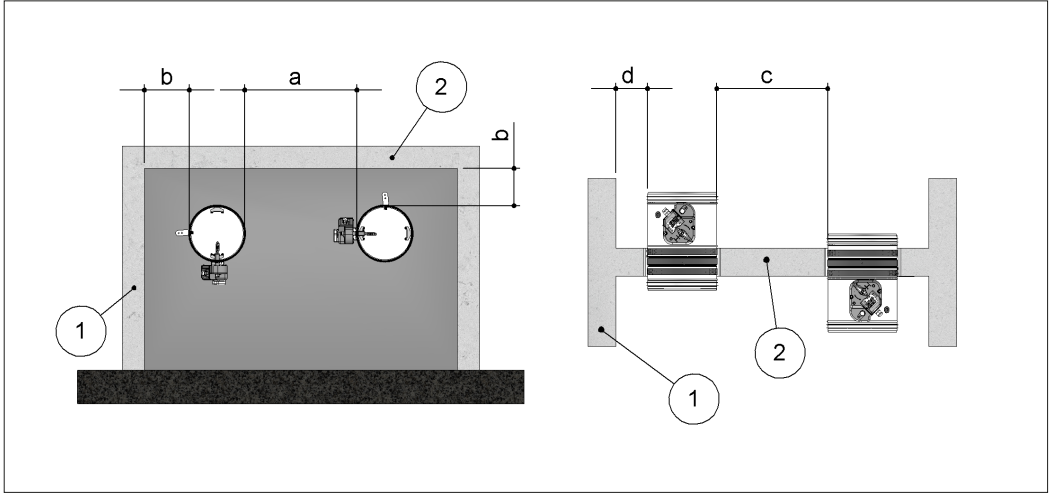

		Fire dampers installed within vertical wall		Fire dampers installed within floor	
Installation		a [mm]	b [mm]	c [mm]	d [mm]
Rigid wall	EI 120 S Installation within vertical rigid wall Mortar or plaster putty sealing	50	75	-	-
	EI 90 S Installation within vertical rigid wall Plasterboard and rock wool 100 kg/m <sup>3</sup> sealing	50	75	-	-
Flexible wall	EI 120 S Installation within vertical light wall (plasterboard) Mortar or plaster putty sealing	50	75	-	-
	EI 90 S Installation within vertical light wall (plasterboard) Plasterboard and rock wool 100 kg/m <sup>3</sup> sealing	50	75	-	-
	EI 60 S Installation within vertical light wall (plasterboard) Plasterboard and rock wool 80 kg/m <sup>3</sup> sealing	50	75	-	-
	EI 120 S Installation within vertical light wall (gypsum blocks wall) Plaster putty sealing	50	75	-	-
	EI 90 S Installation within vertical light wall (gypsum blocks wall) Plaster putty sealing	50	75	-	-
Floor	EI 120 S Installation within floor Mortar sealing	-	-	50	75
	EI 90 S Installation within floor Mortar sealing	-	-	50	75

## ■ Fire Batt (Weichschott) sealings

	Installation	Fire dampers installed within vertical wall		Fire dampers installed within floor	
		a [mm]	b [mm]	c [mm]	d [mm]
Rigid wall	EI 120 S Installation within vertical rigid wall with Fire Batt (Weichschott) sealing Rock wool 140 kg/m <sup>3</sup> and endothermic varnish sealing	50 *	50	-	-
Flexible wall	EI 120 S Installation within vertical light wall (plasterboard) with Fire Batt (Weichschott) sealing Rock wool 140 kg/m <sup>3</sup> and endothermic varnish sealing	50 *	50	-	-
	EI 120 S Installation within vertical light wall (gypsum blocks wall) with Fire Batt (Weichschott) sealing Rock wool 140 kg/m <sup>3</sup> and endothermic varnish sealing	50 *	50	-	-
Floor	EI 90 S Installation within floor and Fire Batt (Weichschott) sealing Rock wool 140 kg/m <sup>3</sup> and endothermic varnish sealing	-	-	200	75

\* For the distance **a** including between 50 mm and 200 mm the fire resistance class is reduced to EI 90 S

## ■ Installation remote from construction support

	Installation	Fire dampers installed within vertical wall		Fire dampers installed within floor	
		a [mm]	b [mm]	c [mm]	d [mm]
Rigid wall	Installation remote from the vertical rigid wall Mortar or plaster putty sealing	200	110 *	-	-
	Installation remote from the vertical rigid wall with Fire Batt (Weichschott) sealing Rock wool 140 kg/m <sup>3</sup> and endothermic varnish sealing	200	110 *	-	-
Flexible wall	Installation remote from vertical light wall (plasterboard) Plasterboard and rock wool 100 kg/m <sup>3</sup> or mortar or plaster putty sealing	200	110 *	-	-
	Installation remote from the vertical light wall (plasterboard) with Fire Batt (Weichschott) sealing Rock wool 140 kg/m <sup>3</sup> and endothermic varnish sealing	200	110 *	-	-
	Installation remote from the vertical light wall (gypsum blocks wall) Mortar or plaster putty sealing	200	110 *	-	-
	Installation remote from the vertical light wall (gypsum blocks wall) with Fire Batt (Weichschott) sealing Rock wool 140 kg/m <sup>3</sup> and endothermic varnish sealing	200	110 *	-	-
Floor	EI 120 S Installation remote from the floor Mortar or plaster putty sealing	-	-	200	110 *
	EI 90 S Installation remote from the floor Mortar or plaster putty sealing	-	-	200	110 *

\* Due to rock wool panels thickness. See installation details.

## ■ Installations within vertical light wall (Shaft wall)

Installation	Fire dampers installed within vertical wall		Fire dampers installed within floor	
	a [mm]	b [mm]	c [mm]	d [mm]
EI 90 S Installation within vertical light wall (Shaft wall) Plasterboard and mortar or plaster putty sealing	50	75	-	-

## ■ Construction supports characteristics

The European standard for fire dampers foresees a precise correlation between the wall/floor characteristics and the fire resistance class obtained, as well as the correlation between wall/floor used for the test and wall/floor used for the actual installation.

The test results obtained on a type of wall/floor are valid also for walls/floor of the same type but with greater thickness and/or density than those used in the test.

For plasterboard walls, the test results are also valid for walls with a greater number of plasterboard layers on each side.

As a result, the indicated thickness and density characteristics are to be considered as minimum values.

The wall/floor in which the fire dampers are installed must be fire class certified according to the standards foreseen for the structure.

## ■ Rigid walls

Can be made with aerated concrete blocks, poured concrete, concrete panels, perforated cell elements in concrete or brick in accordance with the following characteristics:

- minimum thickness 100 mm;
- minimum density 550 kg/m<sup>3</sup>.

The use of a reinforcing beam above the opening is recommended for walls made from concrete blocks, bricks or in concrete cell elements.

For walls built with perforated elements, it is also recommended that the area of the opening be made from full elements (for example aerated concrete blocks) to guarantee the correct adhesion of the mortar.

## 1. Reinforcing beam

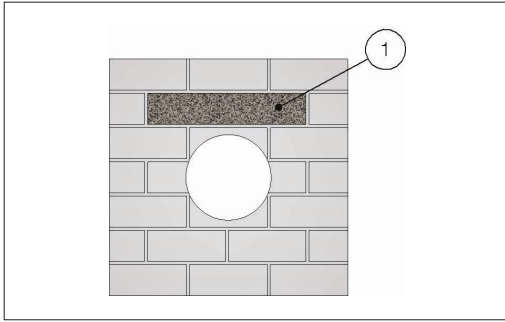

### ■ Light plasterboard vertical walls

During testing, light plasterboard walls have been used with the following characteristics:

- U-shaped horizontal metal frame (50 mm) and C-shaped vertical frame (49 mm) made from 0,6 mm thick sheet metal;
- Vertical profiles placed with a maximum spacing of 625 mm between each other;
- Rock wool filling which has density  $80 \text{ kg/m}^3$ ;
- Each side is made from two plasterboard layers 12,5 mm thick, unalined to avoid alignment between the joints of the layer above and below.

The following indications are given for the installation walls:

- metal profiles minimum width: 49 mm;
- metal profiles minimum thickness: 0,6 mm;
- vertical profiles placed with a maximum spacing of 625 mm between each other;
- vertical profile fixing with selfthreading screws or by clinching to the bottom horizontal profile and insertion in the top horizontal profile;
- profiles fixed using self-threading screws or by clinching on every intersection.
- installation of a frame around the damper with base and height where shown in the installation instructions;
- rock wool filling which has minimum density  $80 \text{ kg/m}^3$ ;
- each side is made from two plasterboard layers 12,5 mm minimum thick, unalined to avoid alignment between the joints of the layer above and below.
- the front plasterboards layers are fixed using long enough screws to pass through the lower plasterboard and attach to the steel profile underneath.

1. Plasterboard thickness 12,5 mm
2. Rock wool density up to  $80 \text{ kg/m}^3$  (optional)
3. Horizontal U-shaped profile
4. Vertical C-shaped profile
5. Self-drilling screw  $\varnothing 3,5 \times 25 \text{ mm}$
6. Self-drilling screw  $\varnothing 3,5 \times 35 \text{ mm}$

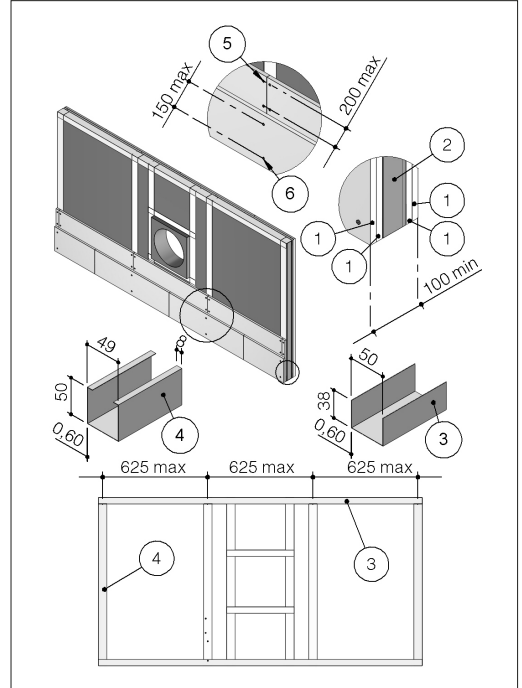

### ■ Light plasterboard vertical walls (Shaft wall)

The following indications are given for the installation walls:

- U-shaped horizontal metal frame (minimum width 50 mm) and C-shaped vertical frame (minimum width 49 mm) made from sheet metal (minimum thickness 0,6 mm);
- vertical profiles placed with a maximum spacing of 1000 mm between each other;
- vertical profile fixing with selfthreading screws or by clinching to the bottom horizontal profile and insertion in the top horizontal profile;
- profiles fixed using self-threading screws or by clinching on every intersection.
- installation of a frame around the damper with base and height where shown in the installation instructions;
- one side is made from two plasterboard layers 20 mm minimum thick, unalined to avoid alignment between the joints of the layer above and below;
- the front plasterboards layers are fixed using long enough screws to pass through the lower plasterboard and attach to the steel profile underneath.

1. Plasterboard thickness 20 mm
2. Horizontal U-shaped profile
3. Vertical C-shaped profile
4. Self-drilling screw  $\varnothing$  3,5 X 35 mm
5. Self-drilling screw  $\varnothing$  3,5 X 55 mm

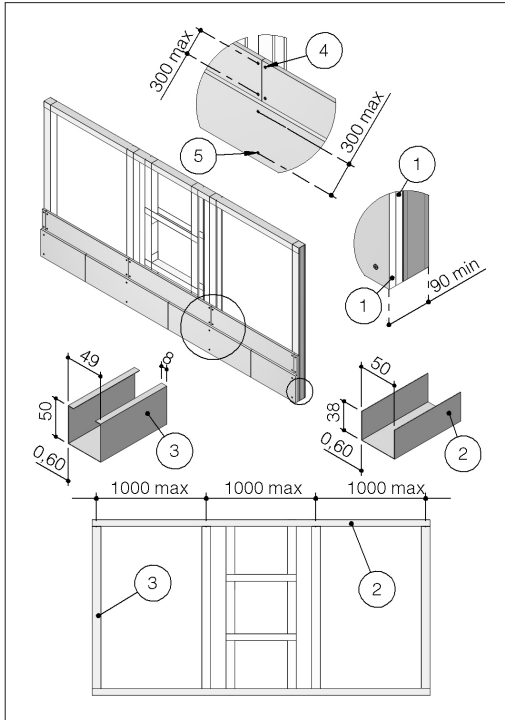

#### ■ Installations within vertical rigid wall

Refer to the section Construction supports characteristics for further information. Comply with the minimum distances indicated on section Minimum distances .

#### ■ Wall opening

A opening must be provided in the wall as indicated in the table and in the drawing

#### ■ Gypsum blocks light walls

Gypsum blocks wall can be built with special solid gypsum blocks with interlocking shaped edges as indicated in the supplier's instructions and according to the following characteristics:

- minimum thickness 70 or 100 mm according to the type and resistance class required;
- minimum density 995 kg/m<sup>3</sup>.

It is generally advisable to first build the wall and then provide the opening for the fire damper.

#### ■ Aerated concrete floors

Aerated concrete floors can be built during installation or with pre-formed slabs with interlocking shaped edges according to the following characteristics:

- minimum thickness 100 or 150 mm according to the type and resistance class required;
- minimum density 650 kg/m<sup>3</sup>

#### ■ Poured concrete floors

Poured concrete floors can be built during installation or with pre-formed slabs with interlocking shaped edges according to the following characteristics:

- minimum thickness 100 or 150 mm according to the resistance class required;
- minimum density 2200 kg/m<sup>3</sup>.

#### ■ Damper positioning

Refer to the section Construction supports characteristics for further information. Comply with the minimum distances indicated on section Minimum distances .

#### ■ Damper positioning

Position the damper in the opening so that the side of the closing mechanism extends as indicated in the drawing.

#### ■ Filling

Fill the space between the wall and the damper as indicated in the table and in the drawing.

	Fire resistance classification	"D" hole size [mm]	Wall minimum thickness "S" [mm]	Sealing
<b>EI 120 S Installation within vertical rigid wall</b>				
Wall minimum density 550 kg/m <sup>3</sup>	EI 120 S (500 Pa)	From $\varnothing + 25$ to $\varnothing + 440$ (circular hole)	100	Mortar or plaster putty sealing
<b>EI 90 S Installation within vertical rigid wall</b>				
Wall minimum density 550 kg/m <sup>3</sup>	EI 90 S (500 Pa)	From $(\varnothing + 50) \times (\varnothing + 50)$ To $(\varnothing + 70) \times (\varnothing + 70)$ (square hole)	100	Rock wool 100 kg/m <sup>3</sup> with infill plasterboard (thickness 12.5 mm)

### EI 120 S Installation within vertical rigid wall

1. Mortar M-10, EN998-2 or plaster putty
- Lp Overlap length between fire damper and duct: see section Dimension
- D Hole size: see table above

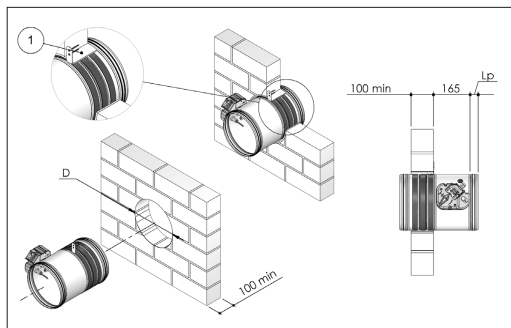

### EI 90 S Installation within vertical rigid wall

1. Plasterboard infill panel, thickness 12,5 mm
2. Rock wool, 100 kg/m<sup>3</sup>
3. Self-drilling screw  $\varnothing$  3,5 X 45 mm
- Lp Overlap length between fire damper and duct: see section Dimension
- D Hole size: see table above

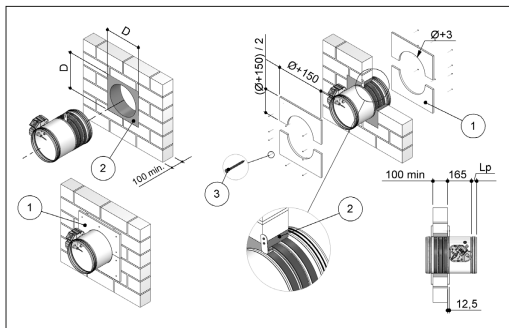

### ■ Installations within vertical light wall (plasterboard)

Refer to the section Construction supports characteristics for further information.

Comply with the minimum distances indicated on section Minimum distances .

### ■ Wall opening

A opening must be provided in the wall as indicated in the table and in the drawing

### ■ Damper positioning

Position the damper in the opening so that the side of the closing mechanism extends as indicated in the drawing.

### ■ Filling

Fill the space between the wall and the damper as indicated in the table and in the drawing.

	Fire resistance classification	"D" hole size [mm]	Wall minimum thickness "S" [mm]	Sealing
<b>EI 60 S Installation within vertical light wall (plasterboard)</b>				
Wall rock wool density up to 80 kg/m <sup>3</sup> (optional)	EI 60 S (500 Pa)	From $(\varnothing + 50) \times (\varnothing + 50)$ To $(\varnothing + 70) \times (\varnothing + 70)$ (square hole)	100	Rock wool 80 kg/m <sup>3</sup> with infill plasterboard (thickness 12.5 mm)
<b>EI 90 S Installation within vertical light wall (plasterboard)</b>				
Wall rock wool density up to 80 kg/m <sup>3</sup> (optional)	EI 90 S (500 Pa)	From $(\varnothing + 50) \times (\varnothing + 50)$ To $(\varnothing + 70) \times (\varnothing + 70)$ (square hole)	100	Rock wool 100 kg/m <sup>3</sup> with infill plasterboard (thickness 12.5 mm)
<b>EI 120 S Installation within vertical light wall (plasterboard)</b>				
Wall rock wool density up to 80 kg/m <sup>3</sup> (optional)	EI 120 S (500 Pa)	From $(\varnothing + 50) \times (\varnothing + 50)$ to $(\varnothing + 440) \times (\varnothing + 440)$ (square hole)	100	Mortar or plaster putty

1. Rock wool density up to 80 kg/m<sup>3</sup> (optional)
  2. Plasterboard arch infill, thickness 12,5 mm for rock wool sealing
  3. Plasterboard thickness 12,5 mm
  4. Sealing: see table above
  5. Self-drilling screw  $\varnothing$  3,5 X 45 mm
  6. Metal frame
- Lp Overlap length between fire damper and duct: see section Dimension
- D Hole size: see table above

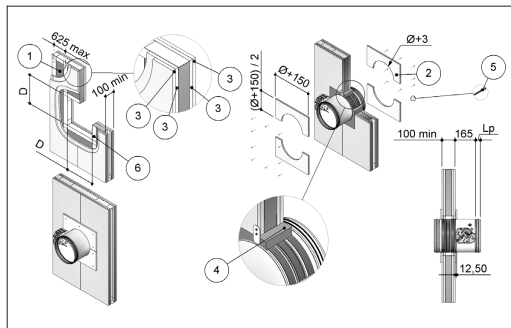

**■ Installations within vertical light wall (gypsum blocks wall)**

Refer to the section Construction supports characteristics for further information.

Comply with the minimum distances indicated on section Minimum distances .

**■ Wall opening**

A opening must be provided in the wall as indicated in the table and in the drawing

**■ Damper positioning**

Position the damper in the opening so that the side of the closing mechanism extends as indicated in the drawing.

**■ Filling**

Fill the space between the wall and the damper as indicated in the table and in the drawing.

	Fire resistance classification	"D" hole size [mm]	Wall minimum thickness "S" [mm]	Sealing
<b>EI 120 S Installation within vertical light wall (gypsum blocks wall)</b>				
Wall minimum density 995 kg/m <sup>3</sup>	EI 120 S (500 Pa)	From Ø + 25 to Ø + 35 (circular hole)	70	Plaster putty sealing
<b>EI 90 S Installation within vertical light wall (gypsum blocks wall)</b>				
Wall minimum density 995 kg/m <sup>3</sup>	EI 90 S (500 Pa)	From Ø + 25 to Ø + 35 (circular hole)	100	Plaster putty sealing

1. Plaster putty

D Hole size: see table above

S Wall minimum thickness: see table above

Lp Overlap length between fire damper and duct: see section Dimension

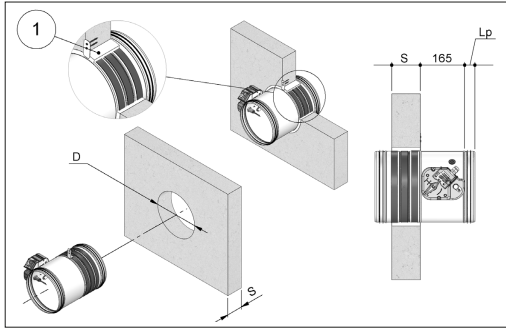

**■ Installations within floor**

Refer to the section Construction supports characteristics for further information.

Comply with the minimum distances indicated on section Minimum distances .

**■ Floor opening**

A opening must be provided in the floor as indicated in the table and in the drawing

**■ Damper positioning**

Position the damper in the opening so that the side of the closing mechanism extends as indicated in the drawing.

**■ Filling**

Fill the space between the floor and the damper as indicated in the table and in the drawing.

	Fire resistance classification	"D" hole size [mm]	Floor minimum thickness "S" [mm]	Sealing
<b>EI 120 S Installation within floor</b>				
Floor minimum density 650 kg/m <sup>3</sup>	EI 120 S (500 Pa)	From Ø + 25 to Ø + 35 (circular hole)	150	Mortar sealing
<b>EI 90 S Installation within floor</b>				
Floor minimum density 650 kg/m <sup>3</sup>	EI 90 S (500 Pa)	From Ø + 25 to Ø + 35 (circular hole)	100	Mortar sealing



- 1. Mortar M-10, EN998-2
- D Hole size: see table above
- S Floor minimum thickness: see table above
- Lp Overlap length between fire damper and duct: see section Dimension

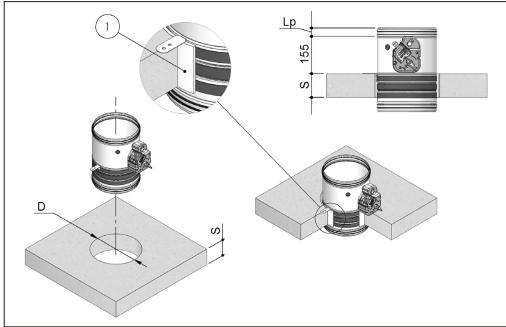

■ Installations within vertical wall with Fire Batt (Weichschott) sealing  
Refer to the section Construction supports characteristics for further information.

Comply with the minimum distances indicated on section Minimum distances .

■ Wall opening

A opening must be provided in the wall as indicated in the table and in the drawing

■ Damper positioning

Position the damper in the opening so that the side of the closing mechanism extends as indicated in the drawing.

The fire damper has to be fixed at the bottom and suspended from the ceiling.

■ Filling

Fill the space between the damper and the wall using Fire Batt (Weichschott) sealing made from two rock wool panels with minimum thickness of 50 mm and minimum density of 140 kg/m<sup>3</sup>. The panels must be covered on both faces of the wall with endothermic varnish type PROMASTOP E PASTE or HILTI CFS-CT (minimum thickness of 1 mm) and with an internal perimeter sealant type PROMASTOP E PASTE or HILTI CFS-S ACR (minimum thickness of 1 mm).

	Fire resistance classification	"D" hole size [mm]	Wall minimum thickness "S" [mm]	Sealing	
Rigid wall	<b>EI 120 S Installation within rigid vertical wall with Fire Batt (Weichschott) sealing</b>				
	Wall minimum density 550 kg/m <sup>3</sup>	EI 120 S (300 Pa)	(Ø + 600 max) x (Ø + 600 max) (rectangular hole)	100	Rock wool 140 kg/m <sup>3</sup> and endothermic varnish sealing
Flexible wall	<b>EI 120 S Installation within vertical light wall (plasterboard) with Fire Batt (Weichschott) sealing</b>				
	Wall rock wool density up to 80 kg/m <sup>3</sup> (optional)	EI 120 S (300 Pa)	(Ø + 600 max) x (Ø + 600 max) (rectangular hole)	100	Rock wool 140 kg/m <sup>3</sup> and endothermic varnish sealing
	<b>EI 120 S Installation within vertical light wall (gypsum blocks) with Fire Batt (Weichschott) sealing</b>				
	Wall minimum density 995 kg/m <sup>3</sup>	EI 120 S (300 Pa)	(Ø + 600 max) x (Ø + 600 max) (rectangular hole)	100	Rock wool 140 kg/m <sup>3</sup> and endothermic varnish sealing

- 1. Rock wool panel 50 mm thick with 140 kg/m<sup>3</sup> density.
- 2. PROMASTOP E PASTE or HILTI CFS-S ACR type sealant
- 3. PROMASTOP E PASTE or HILTI CFS-CT endothermic varnish
- 4. Wall indicated in the table
- Lp Overlap length between fire damper and duct: see section Dimension
- D Hole size: see table above
- S Wall minimum thickness: see table above

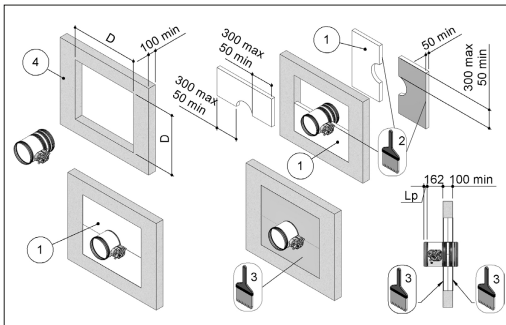

■ Installation within floor with Fire Batt (Weichschott) sealing  
Refer to the section Construction supports characteristics for further information.

Comply with the minimum distances indicated on section Minimum distances .

■ Floor opening

A opening must be provided in the floor as indicated in the table and in the drawing

■ Damper positioning

Position the damper in the opening so that the side of the closing mechanism extends as indicated in the drawing.

The mechanism can be located both above and below the floor.

■ Filling

Fill the space between the damper and the floor using Fire Batt (Weichschott) sealing made from two rock wool panels with minimum thickness of 50 mm and minimum density of 140 kg/m<sup>3</sup>. The panels must be covered on both faces of the wall with endothermic varnish type PROMASTOP E PASTE or HILTI CFS-CT (minimum thickness of 1 mm) and with an internal perimeter sealant type PROMASTOP E PASTE or HILTI CFS-S ACR (minimum thickness of 1 mm).

	Fire resistance classification	"D" hole size [mm]	Floor minimum thickness "S" [mm]	Sealing
<b>EI 90 S Installation within floor and Fire Batt (Weichschott) sealing</b>				
Floor minimum density 650 kg/m <sup>3</sup>	EI 90 S (300 Pa)	(Ø + 600 max) x (Ø + 600 max) (rectangular hole)	150	Rock wool 140 kg/m <sup>3</sup> and endothermic varnish sealing

1. Rock wool panel 50 mm thick with 140 kg/m<sup>3</sup> density.
  2. PROMASTOP E PASTE or HILTI CFS-S ACR type sealant
  3. PROMASTOP E PASTE or HILTI CFS-CT endothermic varnish
- Lp Overlap length between fire damper and duct: see section Dimension  
D Hole size: see table above  
S Floor minimum thickness: see table above

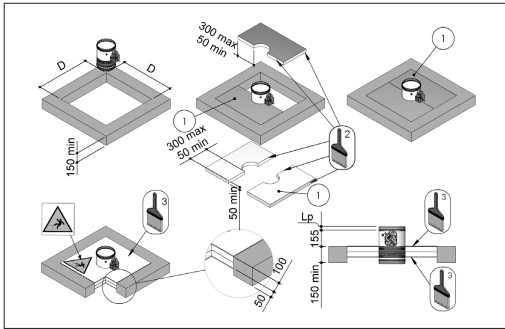

■ Installation remote from the vertical rigid wall and the vertical light wall (gypsum blocks wall)

Refer to the section Construction supports characteristics for further information.

Comply with the minimum distances indicated on section Minimum distances .

■ Wall opening

A opening must be provided in the wall as indicated in the table and in the drawing

■ Damper positioning

Connect fire damper to the galvanized steel duct as indicated in the drawing, with 4 screws Ø4.2x13

Install the damper with the mechanism facing away from the wall as indicated in the drawing.

Between fire damper and wall the maximum distance is 1000 mm.

The maximum length of the part of duct connected to the damper is 2100 mm

The fire damper has to be fixed and suspended from the ceiling as indicated in the drawing.

The hanging structure is composed by:

- 2 C-shaped steel profiles 10x41x41x41x10 mm
- 2 M10 threaded rods
- 4 M10 nuts

Position the threaded rods 1000 mm from the wall and at a distance of 100 mm from the side of the damper.

■ Filling

Fill the space between the wall and the damper using mortar suitable for use in fire resistant constructions, M10 class or higher or plaster putty.

Cover the duct over its entire length and fire damper with 2 rock wool panels 50 mm thick and with a density of 140 kg/m<sup>3</sup>.

Fix first layer of rock wool panel to the duct with screws Ø5 X 60 mm and washers 40 X 40 mm, and the second one with screws Ø5 X 120 mm and washers 40 X 40 mm.

Fill the space between rock wool panels and the damper with one rock wool panel with minimum thickness of 50 mm and minimum density of 140 kg/m<sup>3</sup>.

The panels must be covered externally with endothermic varnish type PROSTOP E PASTE or HILTI CFS-CT (minimum thickness of 1 mm) and with an internal perimeter sealant type PROMOSTOP E PASTE or HILTI CFS-S ACR (minimum thickness of 1 mm).

	Fire resistance classification	"D" hole size [mm]	Wall minimum thickness "S" [mm]	Sealing
<b>Installation remote from the vertical rigid wall</b>				
<b>Rigid wall</b>	EI 120 S (300 Pa) EI 90 S (500 Pa)	From $\varnothing + 25$ to $\varnothing + 440$ (circular hole)	100	Mortar or plaster putty sealing
<b>Installation remote from the vertical light wall (gypsum blocks wall)</b>				
<b>Flexible wall</b>	EI 120 S (300 Pa) EI 90 S (500 Pa)	From $\varnothing + 25$ to $\varnothing + 35$ (circular hole)	100	Mortar or plaster putty sealing

- D Hole size: see table above  
S Wall minimum thickness: see table above  
1. Rock wool panel 50 mm thick with 140 kg/m<sup>3</sup> density.  
2. PROMASTOP E PASTE or HILTI CFS-S ACR type sealant  
3. PROMASTOP E PASTE or HILTI CFS-CT endothermic varnish  
4. Vertical wall  
5. Self-drilling screw  $\varnothing 5 \times 60$  mm  
6. Self-drilling screw  $\varnothing 5 \times 120$  mm  
7. Washer 40 x 40 mm  
8. M10 threaded rod  
9. C-shaped steel profile 10x41x41x10 mm  
10. M10 nut  
11. Self-drilling screw  $\varnothing 4,2 \times 13$  mm  
12. Mortar M-10, EN998-2 or plaster putty

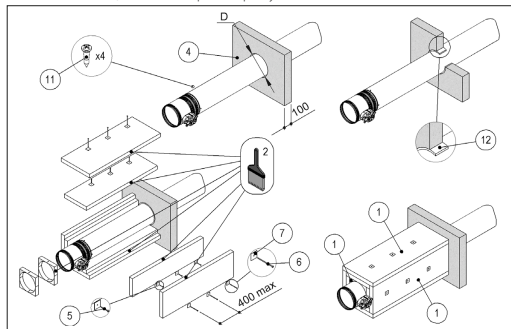
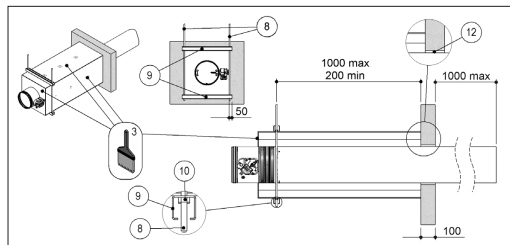

#### ■ Installation remote from the vertical light wall (plasterboard)

Refer to the section Construction supports characteristics for further information.

Comply with the minimum distances indicated on section Minimum distances .

#### ■ Wall opening

A opening must be provided in the wall as indicated in the table and in the drawing

#### ■ Damper positioning

Connect fire damper to the galvanized steel duct as indicated in the drawing, with 4 screws  $\varnothing 4,2 \times 13$

Install the damper with the mechanism facing away from the wall as indicated in the drawing.

Between fire damper and wall the maximum distance is 1000 mm.

The maximum length of the part of duct connected to the damper is 2100 mm

The fire damper has to be fixed and suspended from the ceiling as indicated in the drawing.

The hanging structure is composed by:

- 2 C-shaped steel profiles 10x41x41x10 mm
- 2 M10 threaded rods
- 4 M10 nuts

Position the threaded rods 1000 mm from the wall and at a distance of 100 mm from the side of the damper.

#### ■ Filling

Fill the space between the wall and the fire damper using rock wool which has density of 100 kg/m<sup>3</sup>.

Cover the duct over its entire length and fire damper with 2 rock wool panels 50 mm thick and with a density of 140 kg/m<sup>3</sup>.

Fix first layer of rock wool panel to the duct with screws  $\varnothing 5 \times 60$  mm and washers 40 X 40 mm, and the second one with screws  $\varnothing 5 \times 120$  mm and washers 40 X 40 mm.

Fill the space between rock wool panels and the the damper with one rock wool panel with minimum thickness of 50 mm and minimum density of 140 kg/m<sup>3</sup>.

The panels must be covered externally with endothermic varnish type PROSTOP E PASTE or HILTI CFS-CT (minimum thickness of 1 mm) and with an internal perimeter sealant type PROMOSTOP E PASTE or HILTI CFS-S ACR (minimum thickness of 1 mm).

	Fire resistance classification	"D" hole size [mm]	Wall minimum thickness "S" [mm]	Sealing
<b>Installation remote from the vertical light wall (plasterboard)</b>				
Wall rock wool density up to 100 kg/m <sup>3</sup> (optional)	EI 120 S (300 Pa) EI 90 S (500 Pa)	From (Ø + 50) x (Ø + 50) To (Ø + 70) x (Ø + 70) (square hole)	100	Rock wool 100 kg/m <sup>3</sup> with infill plasterboard (thickness 12.5 mm)
Wall rock wool density up to 100 kg/m <sup>3</sup> (optional)	EI 120 S (300 Pa) EI 90 S (500 Pa)	From (Ø + 50) x (Ø + 50) to (Ø + 440) x (Ø + 440) (square hole)	100	Mortar or plaster putty

- D Hole size: see table above  
S Wall minimum thickness: see table above
1. Rock wool panel 50 mm thick with 140 kg/m<sup>3</sup> density.
  2. PROMASTOP E PASTE or HILTI CFS-S ACR type sealant
  3. PROMASTOP E PASTE or HILTI CFS-CT endothermic varnish
  4. Rock wool, 100 kg/m<sup>3</sup>, or mortar M-10, EN998-2 or plaster putty
  5. Self-drilling screw Ø 5 X 60 mm
  6. Self-drilling screw Ø 5 X 120 mm
  7. Washer 40 x 40 mm
  8. M10 threaded rod
  9. C-shaped steel profile 10x41x41x10 mm
  10. M10 nut
  11. Self-drilling screw Ø 4.2 X 13 mm
  12. Self-drilling screw Ø 3,5 X 45 mm
  13. Plasterboard infill panel, thickness 12,5 mm, for rock wool sealing
  14. Rock wool density up to 80 kg/m<sup>3</sup> (optional)
  15. Metal frame

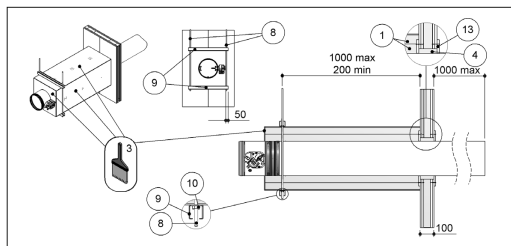
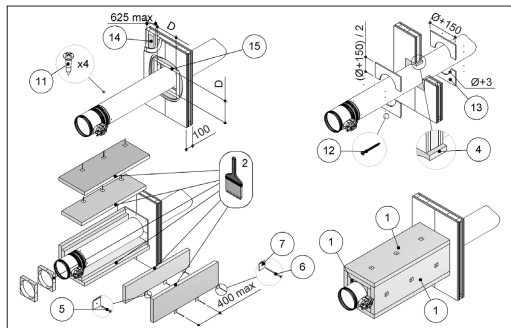

#### ■ Installations remote from the vertical wall with Fire Batt (Weichschott) sealing

Refer to the section Construction supports characteristics for further information.

Comply with the minimum distances indicated on section Minimum distances.

#### ■ Wall opening

A opening must be provided in the wall as indicated in the table and in the drawing

#### ■ Damper positioning

Connect fire damper to the galvanized steel duct as indicated in the drawing, with 4 screws Ø4.2x13

Install the damper with the mechanism facing away from the wall as indicated in the drawing.

Between fire damper and wall the maximum distance is 1000 mm.

The maximum length of the part of duct connected to the damper is 2100 mm

The fire damper has to be fixed and suspended from the ceiling as indicated in the drawing.

The hanging structure is composed by:

- 2 C-shaped steel profiles 10x41x41x10 mm
- 2 M10 threaded rods
- 4 M10 nuts

Position the threaded rods 1000 mm from the wall and at a distance of 100 mm from the side of the damper.

#### ■ Filling

Fill the space between the damper and the wall using Fire Batt (Weichschott) sealing made from two rock wool panels with minimum thickness of 50 mm and minimum density of 140 kg/m<sup>3</sup>.

Cover the duct over its entire length and fire damper with 2 rock wool panels 50 mm thick and with a density of 140 kg/m<sup>3</sup>. Fix first layer of rock wool panel to the duct with screws Ø5 X 60 mm and washers 40 X 40 mm, and the second one with screws Ø5 X 120 mm and washers 40 X 40 mm.

Fill the space between rock wool panels and the the damper with one rock wool panel with minimum thickness of 50 mm and minimum density of 140 kg/m<sup>3</sup>.

The panels must be covered externally with endothermic varnish type PROSTOP E PASTE or HILTI CFS-S ACR type sealant (minimum thickness of 1 mm) and with an internal perimeter sealant type PROMOSTOP E PASTE or HILTI CFS-S ACR (minimum thickness of 1 mm).

	Fire resistance classification	"D" hole size [mm]	Wall minimum thickness "S" [mm]	Sealing
Rigid wall	<b>Installation remote from the vertical rigid wall with Fire Batt (Weichschott) sealing</b>			
	EI 120 S (300 Pa) EI 90 S (500 Pa) Wall minimum density 550 kg/m <sup>3</sup>	(Ø + 600 max) x (Ø + 600 max) (rectangular hole)	100	Rock wool 140 kg/m <sup>3</sup> and endothermic varnish sealing
Flexible wall	<b>Installation remote from vertical light wall (plasterboard) with Fire Batt (Weichschott) sealing</b>			
	EI 120 S (300 Pa) EI 90 S (500 Pa) Wall rock wool density up to 100 kg/m <sup>3</sup> (optional)	(Ø + 600 max) x (Ø + 600 max) (rectangular hole)	100	Rock wool 140 kg/m <sup>3</sup> and endothermic varnish sealing
	<b>Installation remote from vertical light wall (gypsum blocks) with Fire Batt (Weichschott) sealing</b>			
	EI 120 S (300 Pa) EI 90 S (500 Pa) Wall minimum density 995 kg/m <sup>3</sup>	(Ø + 600 max) x (Ø + 600 max) (rectangular hole)	100	Rock wool 140 kg/m <sup>3</sup> and endothermic varnish sealing

D Hole size: see table above

1. Rock wool panel 50 mm thick with 140 kg/m<sup>3</sup> density.
2. PROMASTOP E PASTE or HILTI CFS-S ACR type sealant
3. PROMASTOP E PASTE or HILTI CFS-CT endothermic varnish
4. Wall indicated in the table above
5. Self-drilling screw Ø 5 X 60 mm
6. Self-drilling screw Ø 5 X 120 mm
7. Washer 40 x 40 mm
8. M10 threaded rod
9. C-shaped steel profile 10x41x41x10 mm
10. M10 nut
11. Self-drilling screw Ø 4,2 X 13 mm

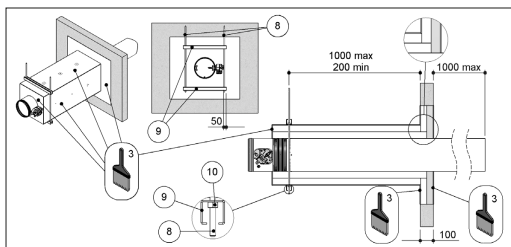
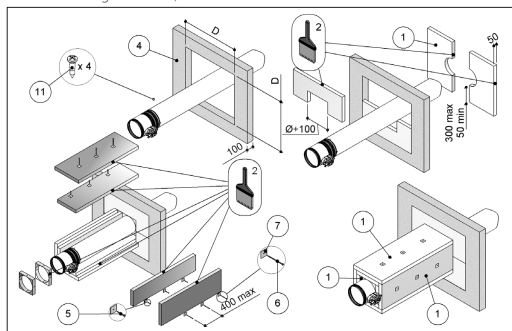

#### ■ Installations remote from the floor

Refer to the section Construction supports characteristics for further information.

Comply with the minimum distances indicated on section Minimum distances .

#### ■ Floor opening

A opening must be provided in the floor as indicated in the table and in the drawing

#### ■ Damper positioning

Connect fire damper to the galvanized steel duct as indicated in the drawing, with 4 screws Ø4.2x13

Install the damper with the mechanism facing away from the floor as indicated in the drawing.

Between fire damper and floor the maximum distance is 1000 mm.

The maximum length of the part of duct connected to the damper is 2150 mm

The fire damper has to be fixed and suspended from the ceiling as indicated in the drawing.

The fire damper must be positioned just above the floor as indicated in the drawing.

The hanging structure is composed by:

- 4 Angle connectors 105x105x90 mm
- Screws M8 x 40 mm
- Washers 15 x 9 mm
- Flush anchors M8 x 40 mm

#### ■ Filling

Fill the space between the floor and the damper using mortar suitable for use in fire resistant constructions, M10 class or higher or plaster putty.

Cover the duct over its entire length and fire damper with 2 rock wool panels 50 mm thick and with a density of 140 kg/m<sup>3</sup>.

Fix first layer of rock wool panel to the duct with screws Ø5 X 60 mm and washers 40 X 40 mm, and the second one with screws Ø5 X 120 mm and washers 40 X 40 mm.

Fill the space between rock wool panels and the the damper with one rock wool panel with minimum thickness of 50 mm and minimum density of 140 kg/m<sup>3</sup>.

The panels must be covered externally with endothermic varnish type PROSTOP E PASTE or HILTI CFS-CT (minimum thickness of 1 mm) and with an internal perimeter sealant type PROMOSTOP E PASTE or HILTI CFS-S ACR (minimum thickness of 1 mm).

	Fire resistance classification	"D" hole size [mm]	Wall minimum thickness "S" [mm]	Sealing
<b>EI 90 S Installation remote from the floor</b>				
Floor minimum density 650 kg/m <sup>3</sup>	EI 90 S (500 Pa)	From Ø + 25 to Ø + 35 (circular hole)	100	Mortar or plaster putty sealing
<b>EI 120 S Installation remote from the floor</b>				
Floor minimum density 650 kg/m <sup>3</sup>	EI 120 S (300 Pa)	From Ø + 25 to Ø + 35 (circular hole)	150	Mortar or plaster putty sealing

**The fire damper must be positioned just above the floor as indicated in the drawing.**

1. Floor
2. Duct
3. Fire damper

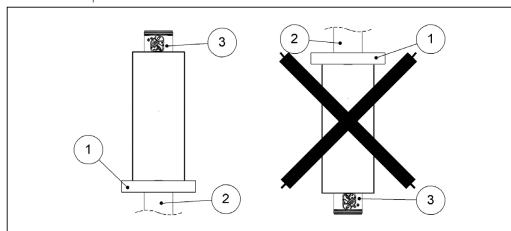

- D Hole size: see table above
- S Wall minimum thickness: see table above
1. Self-drilling screw Ø 4,2 X 13 mm
2. PROMASTOP E PASTE or HILTI CFS-S ACR type sealant
3. PROMASTOP E PASTE or HILTI CFS-CT endothermic varnish
4. Screws M8 x 40 mm
5. Washers 15 x 9 mm
6. Angle connector 105 X 105 X 90 mm
7. Washers 15 x 5 mm
8. Mortar M-10, EN998-2 or plaster putty
9. Washer 40 x 40 mm
10. Self-drilling screw Ø 5 X 60 mm
11. Self-drilling screw Ø 5 X 120 mm
12. Rock wool panel 50 mm thick with 140 kg/m<sup>3</sup> density.
13. Flush anchors M8 x 40 mm
14. Floor

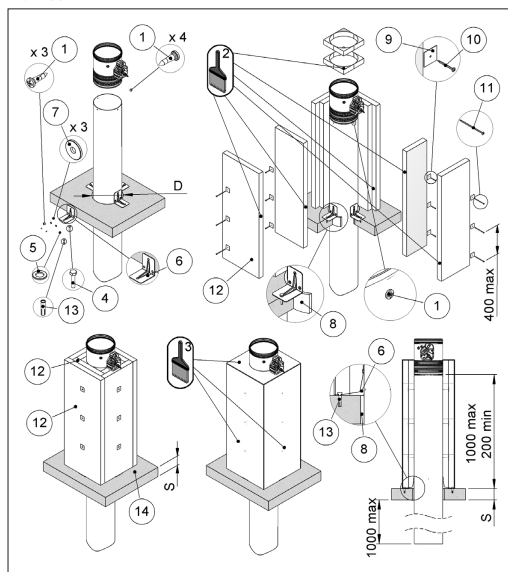

■ Installation within vertical light wall (Shaft wall)

Refer to the section Construction supports characteristics for further information. Comply with the minimum distances indicated on section Minimum distances.

■ Wall opening

An opening must be provided in the wall as indicated in the table and in the drawing

■ Damper positioning

Position the damper in the opening so that the side of the closing mechanism extends as indicated in the table and in the drawing.

■ Filling

Fill the space between the wall and the damper as indicated in the table and in the drawing. Cover the sealing by applying on both faces of the wall a layer of plasterboard, to a total minimum thickness of 20 mm per side, to make a frame with a side 150 mm greater than the nominal diameter of the damper.

	Fire resistance classification	"D" hole size [mm]	Wall minimum thickness "S" [mm]	Sealing
<b>EI 90 S Installation within vertical light wall (Shaft wall)</b>				
	EI 90 S (300 Pa)	From $(\varnothing + 50) \times (\varnothing + 50)$ To $(\varnothing + 70) \times (\varnothing + 70)$ (square hole)	90	Mortar or plaster putty with infill plasterboard (thickness 20 mm)

1. Plasterboard thickness 20 mm
  2. Plasterboard arch infill, thickness 20 mm
  3. Mortar M-10, EN998-2 or plaster putty
  4. Metal frame
  5. Self-drilling screw  $\varnothing 3,5 \times 45$  mm
- D Hole size: see table above  
Lp Overlap length between fire damper and duct: see section Dimension

